

---

---

**Internal combustion engines —  
Piston rings —**

**Part 4:  
Half keystone rings made of steel**

*Moteurs à combustion interne — Segments de piston —*

*Partie 4: Segments semi-trapézoïdaux en acier*

<https://standards.iteh.ai>  
Document Preview

[ISO 6624-4:2016](https://standards.iteh.ai/catalog/standards/iso/955d7d94-f5d7-424b-8aca-c4f401f403f3/iso-6624-4-2016)

<https://standards.iteh.ai/catalog/standards/iso/955d7d94-f5d7-424b-8aca-c4f401f403f3/iso-6624-4-2016>



iTeh Standards  
(<https://standards.iteh.ai>)  
Document Preview

[ISO 6624-4:2016](https://standards.iteh.ai/catalog/standards/iso/955d7d94-f5d7-424b-8aca-c4f401f403f3/iso-6624-4-2016)

<https://standards.iteh.ai/catalog/standards/iso/955d7d94-f5d7-424b-8aca-c4f401f403f3/iso-6624-4-2016>



**COPYRIGHT PROTECTED DOCUMENT**

© ISO 2016, Published in Switzerland

All rights reserved. Unless otherwise specified, no part of this publication may be reproduced or utilized otherwise in any form or by any means, electronic or mechanical, including photocopying, or posting on the internet or an intranet, without prior written permission. Permission can be requested from either ISO at the address below or ISO's member body in the country of the requester.

ISO copyright office  
Ch. de Blandonnet 8 • CP 401  
CH-1214 Vernier, Geneva, Switzerland  
Tel. +41 22 749 01 11  
Fax +41 22 749 09 47  
[copyright@iso.org](mailto:copyright@iso.org)  
[www.iso.org](http://www.iso.org)

# Contents

Page

<b>Foreword</b> .....	<b>iv</b>
<b>Introduction</b> .....	<b>v</b>
<b>1 Scope</b> .....	<b>1</b>
<b>2 Normative references</b> .....	<b>1</b>
<b>3 Overview</b> .....	<b>1</b>
<b>4 Ring types and designation examples</b> .....	<b>1</b>
4.1 Type HK — Straight faced half keystone ring 7°.....	1
4.1.1 General features.....	1
4.1.2 Designation.....	2
4.2 Type HKB — Barrel faced half keystone ring 7°.....	2
4.2.1 General features.....	2
4.2.2 Designation.....	4
4.3 Type HKBA — Asymmetrical Barrel faced half keystone ring 7° (not recommended for nitrided rings of code NT).....	4
4.3.1 General features.....	4
4.3.2 Designation.....	6
<b>5 Common features</b> .....	<b>6</b>
5.1 Type HK, HKB and HKBA — Half keystone rings.....	6
5.1.1 Nitrided rings (not recommended for HKBA rings with Nitrided code NT).....	6
5.1.2 PVD rings.....	6
5.1.3 Chromium plated or spray coated rings.....	7
5.2 Type HK, HKB and HKBA rings — Outside and inside rounded edges.....	7
5.3 Type HK, HKB and HKBA rings (fully faced and inlaid) — Plating/coating thickness.....	8
5.4 Type HK, HKB and HKBA rings — Nitrided case depth.....	9
<b>6 Force factors</b> .....	<b>10</b>
<b>7 Dimensions and forces</b> .....	<b>10</b>
<b>Annex A (normative) Calculation of measurement width <math>h_3</math> of half keystone rings</b> .....	<b>19</b>
<b>Bibliography</b> .....	<b>20</b>

## Foreword

ISO (the International Organization for Standardization) is a worldwide federation of national standards bodies (ISO member bodies). The work of preparing International Standards is normally carried out through ISO technical committees. Each member body interested in a subject for which a technical committee has been established has the right to be represented on that committee. International organizations, governmental and non-governmental, in liaison with ISO, also take part in the work. ISO collaborates closely with the International Electrotechnical Commission (IEC) on all matters of electrotechnical standardization.

The procedures used to develop this document and those intended for its further maintenance are described in the ISO/IEC Directives, Part 1. In particular the different approval criteria needed for the different types of ISO documents should be noted. This document was drafted in accordance with the editorial rules of the ISO/IEC Directives, Part 2 (see [www.iso.org/directives](http://www.iso.org/directives)).

Attention is drawn to the possibility that some of the elements of this document may be the subject of patent rights. ISO shall not be held responsible for identifying any or all such patent rights. Details of any patent rights identified during the development of the document will be in the Introduction and/or on the ISO list of patent declarations received (see [www.iso.org/patents](http://www.iso.org/patents)).

Any trade name used in this document is information given for the convenience of users and does not constitute an endorsement.

For an explanation on the meaning of ISO specific terms and expressions related to conformity assessment, as well as information about ISO's adherence to the WTO principles in the Technical Barriers to Trade (TBT) see the following URL: [Foreword - Supplementary information](#)

The committee responsible for this document is ISO/TC 22, *Road vehicles*, Subcommittee SC 34, *Propulsion, powertrain and powertrain fluids*.

This second edition cancels and replaces the first edition (ISO 6624-4:2003), which has been technically revised.

ISO 6624 consists of the following parts, under the general title *Internal combustion engines — Piston rings*:

- *Part 1: Keystone rings made of cast iron*
- *Part 2: Half keystone rings made of cast iron*
- *Part 3: Keystone rings made of steel*
- *Part 4: Half keystone rings made of steel*

## Introduction

ISO 6624 is one of a number of series of International Standards dealing with piston rings for reciprocating internal combustion engines. Others are ISO 6621,<sup>[2][3][4][5]</sup> ISO 6622,<sup>[6],[7]</sup> ISO 6623,<sup>[8]</sup> ISO 6625,<sup>[9]</sup> ISO 6626,<sup>[10][11][12]</sup> and ISO 6627.<sup>[13]</sup>

**iTeh Standards**  
(<https://standards.itih.ai>)  
**Document Preview**

[ISO 6624-4:2016](https://standards.itih.ai/catalog/standards/iso/955d7d94-f5d7-424b-8aca-c4f401f403f3/iso-6624-4-2016)

<https://standards.itih.ai/catalog/standards/iso/955d7d94-f5d7-424b-8aca-c4f401f403f3/iso-6624-4-2016>



# Internal combustion engines — Piston rings —

## Part 4: Half keystone rings made of steel

### 1 Scope

This part of ISO 6624 specifies the essential dimensional features of half keystone rings made of steel, types HK, HKB and HKBA, having nominal diameters from 50 mm up to, and including, 160 mm, used in reciprocating internal combustion piston engines for road vehicles and other applications.

### 2 Normative references

The following documents, in whole or in part, are normatively referenced in this document and are indispensable for its application. For dated references, only the edition cited applies. For undated references, the latest edition of the referenced document (including any amendments) applies.

ISO 6621-4, *Internal combustion engines — Piston rings — Part 4: General specifications*

### 3 Overview

The half keystone ring types are specified in [Tables 1 and 2](#) and [Figures 1, 2 and 3](#). Their common features and the dimensions of those features are specified in [Tables 3 to 6](#) and [Figures 4 to 10](#). [Table 7](#) gives the force factors for the different ring types, while [Table 8](#) gives the dimensions and forces of half keystone rings.

The common features and dimensional tables presented in this part of ISO 6624 constitute a broad range of variables and, in selecting a particular ring type, the designer shall bear in mind the conditions under which it will be required to operate.

It is also essential that the designer refer to the specifications and requirements of ISO 6621-3<sup>[4]</sup> and ISO 6621-4 before completing selection.

### 4 Ring types and designation examples

NOTE For the angle of half keystone rings, the same definition and measurement apply as for keystone rings (see ISO 6621-2).

#### 4.1 Type HK — Straight faced half keystone ring 7°

##### 4.1.1 General features

[Figure 1](#) shows the general features of piston ring type HK.

See [Table 7](#) for dimensions and forces.

$h_3$  values are calculated based on [Annex A](#).

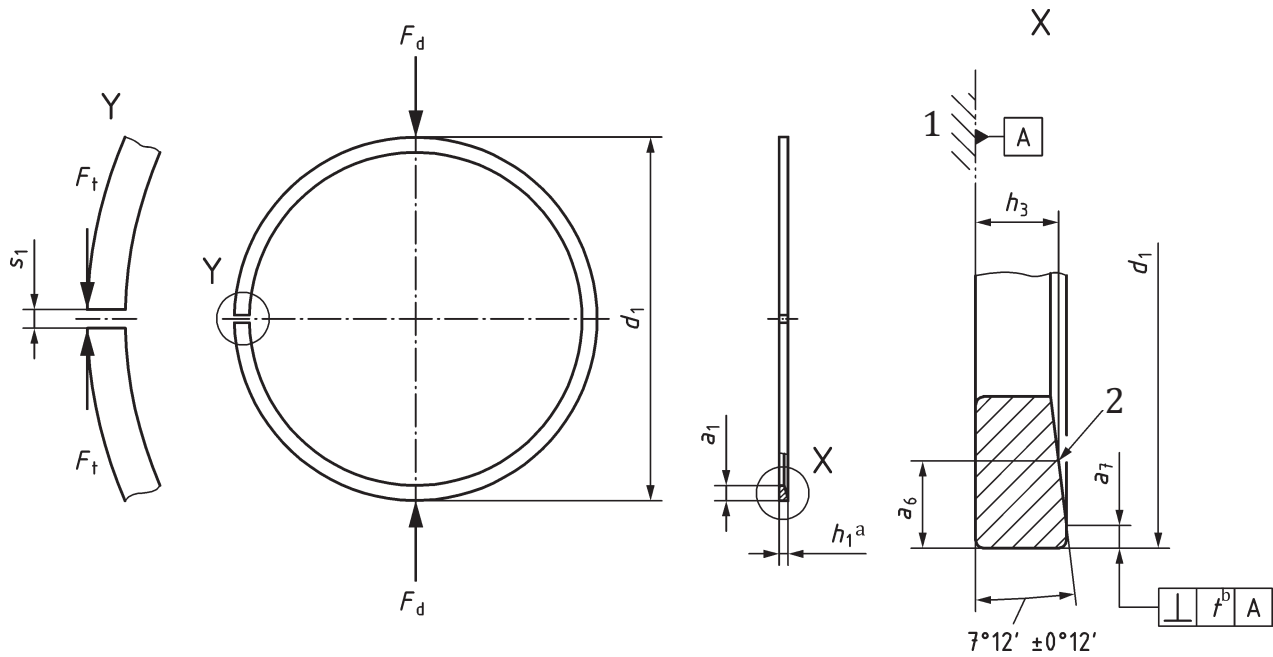

**Key**

- 1 reference plane (ring is positioned flat against datum A)
- 2 top side identification mark
- a Nominal.
- b  $t = 0,006 \times h_1$ .

iTeh Standards  
(<https://standards.itih.ai>)  
Document Preview

**Figure 1 — Type HK**

**4.1.2 Designation**

ISO 6624-4:2016

EXAMPLE <sup>16</sup> Designation of a piston ring complying with the requirements of ISO 6624-4, being a 7° half keystone ring made of steel with a straight faced peripheral surface (HK), of nominal diameter  $d_1 = 60$  mm (60), of nominal ring width  $h_1 = 1,2$  mm (1,2), made of CrSi alloyed steel subclass 62 (MC62), and having a chromium plated peripheral surface with a minimum thickness of 0,1 mm (CR2). Parameters in parenthesis are used in the ISO ring designation:

**Piston ring ISO 6624-4 HK - 60 × 1,2 - MC62/CR2**

**4.2 Type HKB — Barrel faced half keystone ring 7°**

**4.2.1 General features**

[Figure 2](#) shows the general features of piston ring type HKB.

See [Table 7](#) for dimensions and forces.

$h_3$  values are calculated based on [Annex A](#).



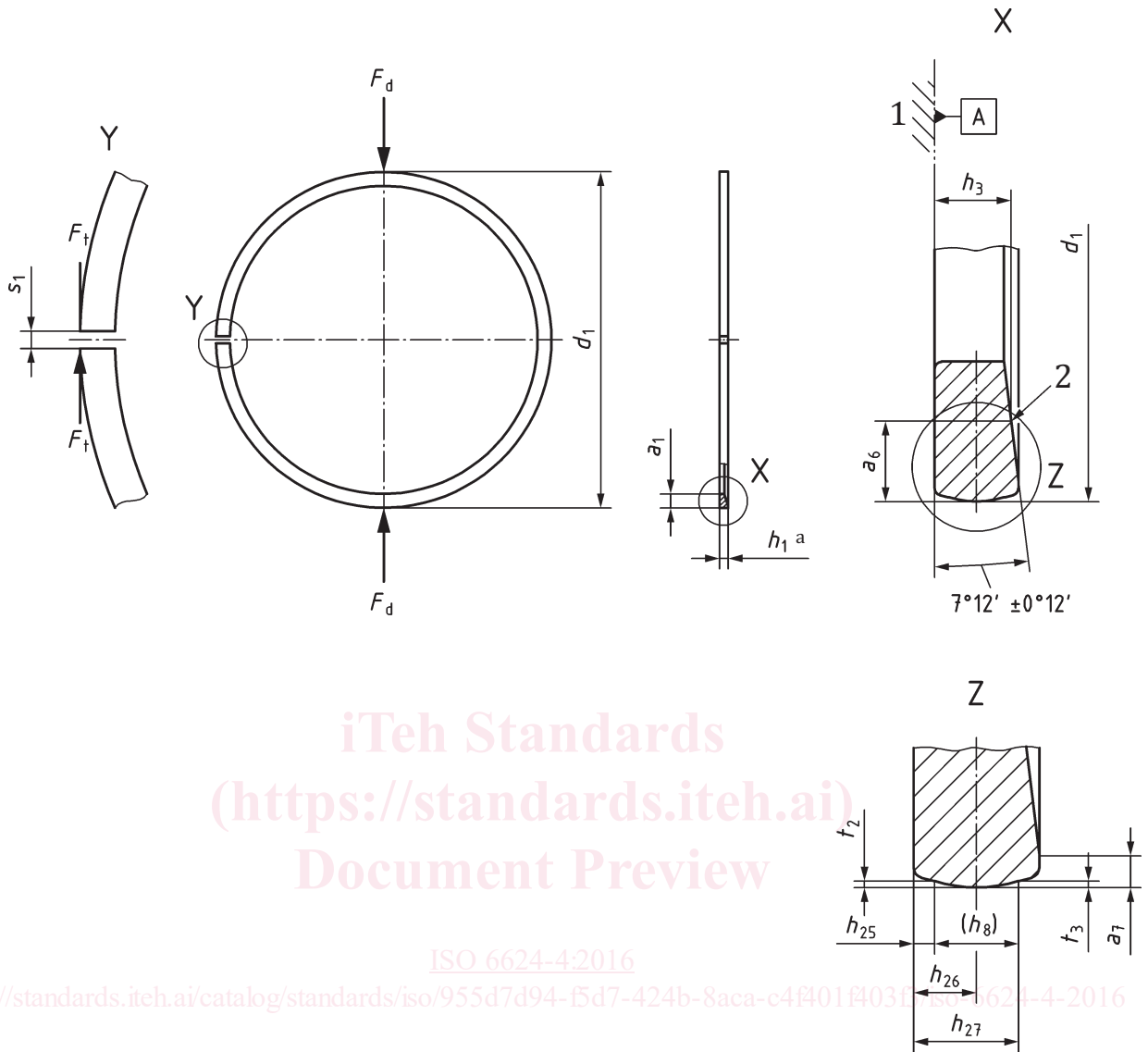

iTeh Standards  
 (https://standards.itih.ai)  
 Document Preview

ISO 6624-4:2016

https://standards.itih.ai/catalog/standards/iso/955d7d94-f5d7-424b-8aca-c4f401f40317/iso-6624-4-2016

**Key**

- 1 reference plane (ring is positioned flat against datum A)
- 2 top side identification mark
- a Nominal.

**Figure 2 — Type HKB**

Table 1 — Symmetrical barrel dimensions and gauge width ( $h_3$ )

Dimensions in millimetres

$h_1$	$h_{25}$	$h_{26}$	$h_{26}$ tol.	$h_{27}$	$t_2, t_3$	$h_3^a$
1,2	0,30	0,60	$\pm 0,20$	0,90	0,002...0,012	0,60
1,5	0,35	0,75	$\pm 0,25$	1,15	0,003...0,015	0,80
1,75	0,35	0,85	$\pm 0,30$	1,35		1,00
2,0	0,40	1,00	$\pm 0,30$	1,60		1,20
2,5	0,45	1,25	$\pm 0,40$	2,05		1,60
3,0	0,50	1,50	$\pm 0,50$	2,50	0,005...0,020	2,00
3,5	0,55	1,75	$\pm 0,50$	2,95		2,40

<sup>a</sup> Gauge width ( $h_3$ ) only informative; may be used only if agreed between manufacturer and customer.

#### 4.2.2 Designation

**EXAMPLE** Designation of a piston ring complying with the requirements of ISO 6624-4, being a half keystone ring made of steel with a barrel faced peripheral surface (HKB), of nominal diameter  $d_1 = 60$  mm (60), of nominal ring width  $h_1 = 1,5$  mm (1,5), made of martensitic steel 11 %Cr (min.) subclass 65 (MC65), and nitrided on the peripheral surface and side faces (NT) to a depth of 0,050 mm min. on the peripheral surface (050), with an associated side face depth of 0,015 mm min. Parameters in parenthesis are used in the ISO ring designation:

**Piston ring ISO 6624-4 HKB - 60 × 1,5 - MC65/NT050**

#### 4.3 Type HKBA — Asymmetrical Barrel faced half keystone ring 7° (not recommended for nitrided rings of code NT)

##### 4.3.1 General features

See [Table 7](#) for dimensions and forces.

$h_3$  values are calculated based on [Annex A](#).