



DRAFT INTERNATIONAL STANDARD ISO/DIS 6624-4

ISO/TC 22

Secretariat: AFNOR

Voting begins on
2012-03-29

Voting terminates on
2012-08-29

INTERNATIONAL ORGANIZATION FOR STANDARDIZATION • МЕЖДУНАРОДНАЯ ОРГАНИЗАЦИЯ ПО СТАНДАРТИЗАЦИИ • ORGANISATION INTERNATIONALE DE NORMALISATION

Internal combustion engines — Piston rings —

Part 4: Half keystone rings made of steel

Moteurs à combustion interne — Segments de piston —

Partie 4: Segments semi-trapézoïdaux en acier

[Revision of first edition (ISO 6624-4:2003)]

ICS 43.060.10

iTeh STANDARD PREVIEW
(standards.itih.ai)
Full standard:
<https://standards.itih.ai/catalog/standards/sist/955d7d94-f5d7-424b-8aca-e4f401f403f3/iso-6624-4-2016>

To expedite distribution, this document is circulated as received from the committee secretariat. ISO Central Secretariat work of editing and text composition will be undertaken at publication stage.

Pour accélérer la distribution, le présent document est distribué tel qu'il est parvenu du secrétariat du comité. Le travail de rédaction et de composition de texte sera effectué au Secrétariat central de l'ISO au stade de publication.

THIS DOCUMENT IS A DRAFT CIRCULATED FOR COMMENT AND APPROVAL. IT IS THEREFORE SUBJECT TO CHANGE AND MAY NOT BE REFERRED TO AS AN INTERNATIONAL STANDARD UNTIL PUBLISHED AS SUCH.

IN ADDITION TO THEIR EVALUATION AS BEING ACCEPTABLE FOR INDUSTRIAL, TECHNOLOGICAL, COMMERCIAL AND USER PURPOSES, DRAFT INTERNATIONAL STANDARDS MAY ON OCCASION HAVE TO BE CONSIDERED IN THE LIGHT OF THEIR POTENTIAL TO BECOME STANDARDS TO WHICH REFERENCE MAY BE MADE IN NATIONAL REGULATIONS.

RECIPIENTS OF THIS DRAFT ARE INVITED TO SUBMIT, WITH THEIR COMMENTS, NOTIFICATION OF ANY RELEVANT PATENT RIGHTS OF WHICH THEY ARE AWARE AND TO PROVIDE SUPPORTING DOCUMENTATION.

iTeh STANDARD PREVIEW
(standards.iteh.ai)

Full standard:
<https://standards.iteh.ai/catalog/standards/sist/955d7d94-f5d7-424b-8aca-e4f401f403f3/iso-6624-4-2016>

Copyright notice

This ISO document is a Draft International Standard and is copyright-protected by ISO. Except as permitted under the applicable laws of the user's country, neither this ISO draft nor any extract from it may be reproduced, stored in a retrieval system or transmitted in any form or by any means, electronic, photocopying, recording or otherwise, without prior written permission being secured.

Requests for permission to reproduce should be addressed to either ISO at the address below or ISO's member body in the country of the requester.

ISO copyright office
Case postale 56 • CH-1211 Geneva 20
Tel. + 41 22 749 01 11
Fax + 41 22 749 09 47
E-mail copyright@iso.org
Web www.iso.org

Reproduction may be subject to royalty payments or a licensing agreement.

Violators may be prosecuted.

Contents

Page

Foreword	iv
Introduction.....	v
1 Scope	1
2 Normative references	1
3 Overview.....	1
4 Ring types and designation examples	1
4.1 Type HK — Straight faced half keystone ring 7°	1
4.1.1 General features	1
4.1.2 Designation	2
4.2 Type HKB — Barrel faced half keystone ring 7°	2
4.2.1 General features	2
4.2.2 Designation	4
4.3 Type HKBA — Asymmetrical Barrel faced half keystone ring 7° (not recommended for nitrided rings of code NT)	4
4.3.1 General features	4
4.3.2 Designation	6
5 Common features	6
5.1 Type HK, HKB and HKBA — Half keystone rings	6
5.1.1 Nitrided rings (not recommended for HKBA rings with Nitrided code NT)	6
5.1.2 PVD rings.....	7
5.1.3 Chromium plated or spray coated rings	7
5.2 Type HK, HKB and HKBA rings — Outside and inside rounded edges	8
5.3 Type HK, HKB and HKBA rings (fully faced and inlaid) — Plating/coating thickness	8
5.4 Type HK, HKB and HKBA rings — Nitrided case depth	9
6 Force factors.....	10
7 Dimensions	11
Annex A (normative) Calculation of measurement width h_3 of half keystone rings.....	20
Bibliography.....	21

Foreword

ISO (the International Organization for Standardization) is a worldwide federation of national standards bodies (ISO member bodies). The work of preparing International Standards is normally carried out through ISO technical committees. Each member body interested in a subject for which a technical committee has been established has the right to be represented on that committee. International organizations, governmental and non-governmental, in liaison with ISO, also take part in the work. ISO collaborates closely with the International Electrotechnical Commission (IEC) on all matters of electrotechnical standardization.

International Standards are drafted in accordance with the rules given in the ISO/IEC Directives, Part 2.

The main task of technical committees is to prepare International Standards. Draft International Standards adopted by the technical committees are circulated to the member bodies for voting. Publication as an International Standard requires approval by at least 75 % of the member bodies casting a vote.

Attention is drawn to the possibility that some of the elements of this document may be the subject of patent rights. ISO shall not be held responsible for identifying any or all such patent rights.

ISO 6624-4 was prepared by Technical Committee ISO/TC 22, *Road Vehicles*.

This second edition cancels and replaces the first edition (ISO 6624-4:2003), which has been technically revised.

ISO 6624 consists of the following parts, under the general title *Internal combustion engines — Piston rings*:

- *Part 1: Keystone rings made of cast iron*
- *Part 2: Half keystone rings made of cast iron*
- *Part 3: Keystone rings made of steel*
- *Part 4: Half keystone rings made of steel*

Introduction

ISO 6624 is one of a number of series of International Standards dealing with piston rings for reciprocating internal combustion engines. Others are ISO 6621^{[2], [3], [4], [5]}, ISO 6622^{[6], [7]}, ISO 6623^[8], ISO 6625^[9], ISO 6626^{[10], [11], [12]} and ISO 6627^[13].

The common features and dimensional tables presented in this part of ISO 6624 constitute a broad range of variables and, in selecting a particular ring type, the designer shall bear in mind the conditions under which it will be required to operate.

It is also essential that the designer refer to the specifications and requirements of ISO 6621-3^[4] and ISO 6621-4 before completing selection.

iTeh STANDARD PREVIEW
(standards.iteh.ai)

Full standard:
<https://standards.iteh.ai/catalog/standards/sist/955d7d94-f5d7-424b-8aca-c4f401f403f3/iso-6624-4-2016>

iTeh STANDARD PREVIEW
(standards.iteh.ai)

Full standard:
<https://standards.iteh.ai/catalog/standards/sist/955d7d94-f5d7-424b-8aca-c4f401f403f3/iso-6624-4-2016>

Internal combustion engines — Piston rings —

Part 4: Half keystone rings made of steel

1 Scope

This part of ISO 6624 specifies the essential dimensional features of half keystone rings made of steel, types HK, HKB and HKBA, having diameters of from 38 mm up to and including 160 mm, used in reciprocating internal combustion piston engines.

2 Normative references

The following referenced documents are indispensable for the application of this document. For dated references, only the edition cited applies. For undated references, the latest edition of the referenced document (including any amendments) applies.

ISO 6621-4, *Internal combustion engines — Piston rings — Part 4: General specifications*

3 Overview

The half keystone ring types are specified in Table 1, 2 and Figures 1, 2 and 3. Their common features and the dimensions of those features are specified in Tables 3 to 6 and Figures 4 to 10. Table 7 gives the force factors for the different ring types, while Table 8 gives the dimensions and forces of half keystone rings.

4 Ring types and designation examples

NOTE For the angle of half keystone rings, the same definition and measurement apply as for keystone rings (see ISO 6621-2).

4.1 Type HK — Straight faced half keystone ring 7°

4.1.1 General features

Figure 1 shows the general features of piston ring type HK.

See Table 7 for dimensions and forces.

h_3 values are calculated based on $h_1 + 0,05$ mm.

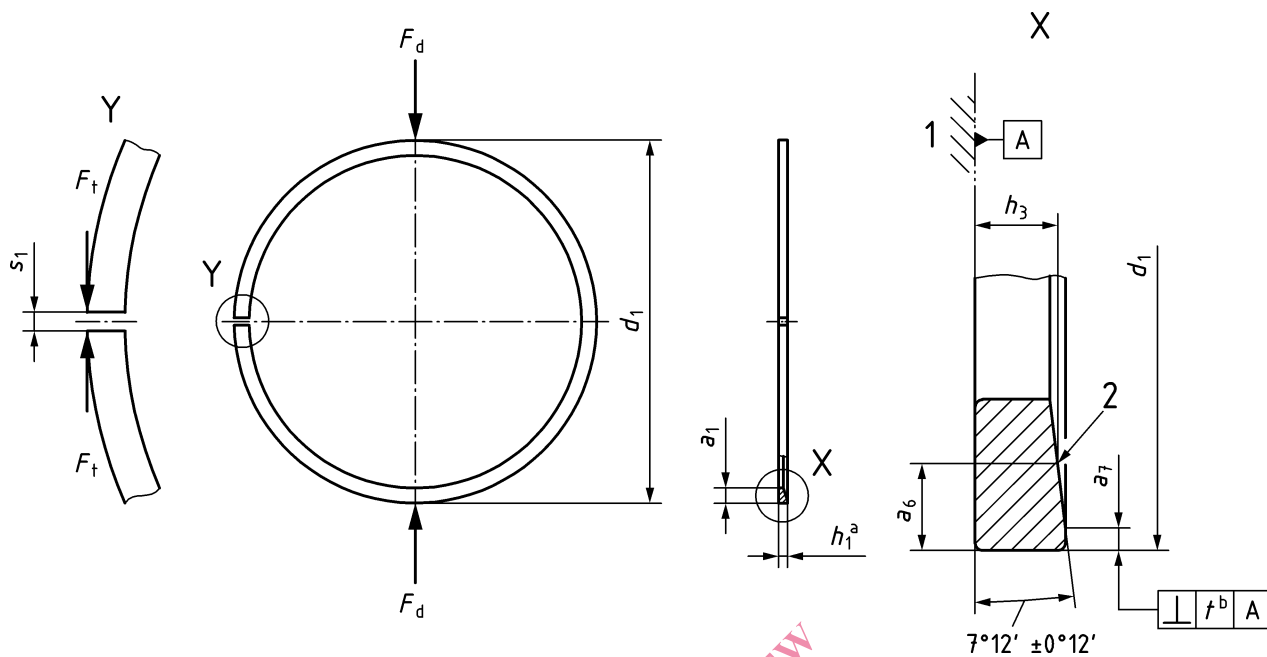

- Key**
- 1 reference plane
 - 2 top side identification mark
 - a Nominal.
 - b $t = 0,006 \times h_1$.

Figure 1 — Type HK

4.1.2 Designation

EXAMPLE Designation of a piston ring complying with the requirements of ISO 6624-4, being a 7° half keystone ring made of steel with a straight faced peripheral surface (HK), of nominal diameter $d_1 = 60$ mm (60), of nominal ring width $h_1 = 1,2$ mm (1,2), made of CrSi alloyed steel subclass 62 (MC62), and having a chromium plated peripheral surface with a minimum thickness of 0,1 mm (CR2):

Piston ring ISO 6624-4 HK - 60 × 1,2 - MC62/CR2

4.2 Type HKB — Barrel faced half keystone ring 7°

4.2.1 General features

Figure 2 shows the general features of piston ring type HKB.

See Table 7 for dimensions and forces.

h_3 values are calculated based on $h_1 + 0,05$ mm.

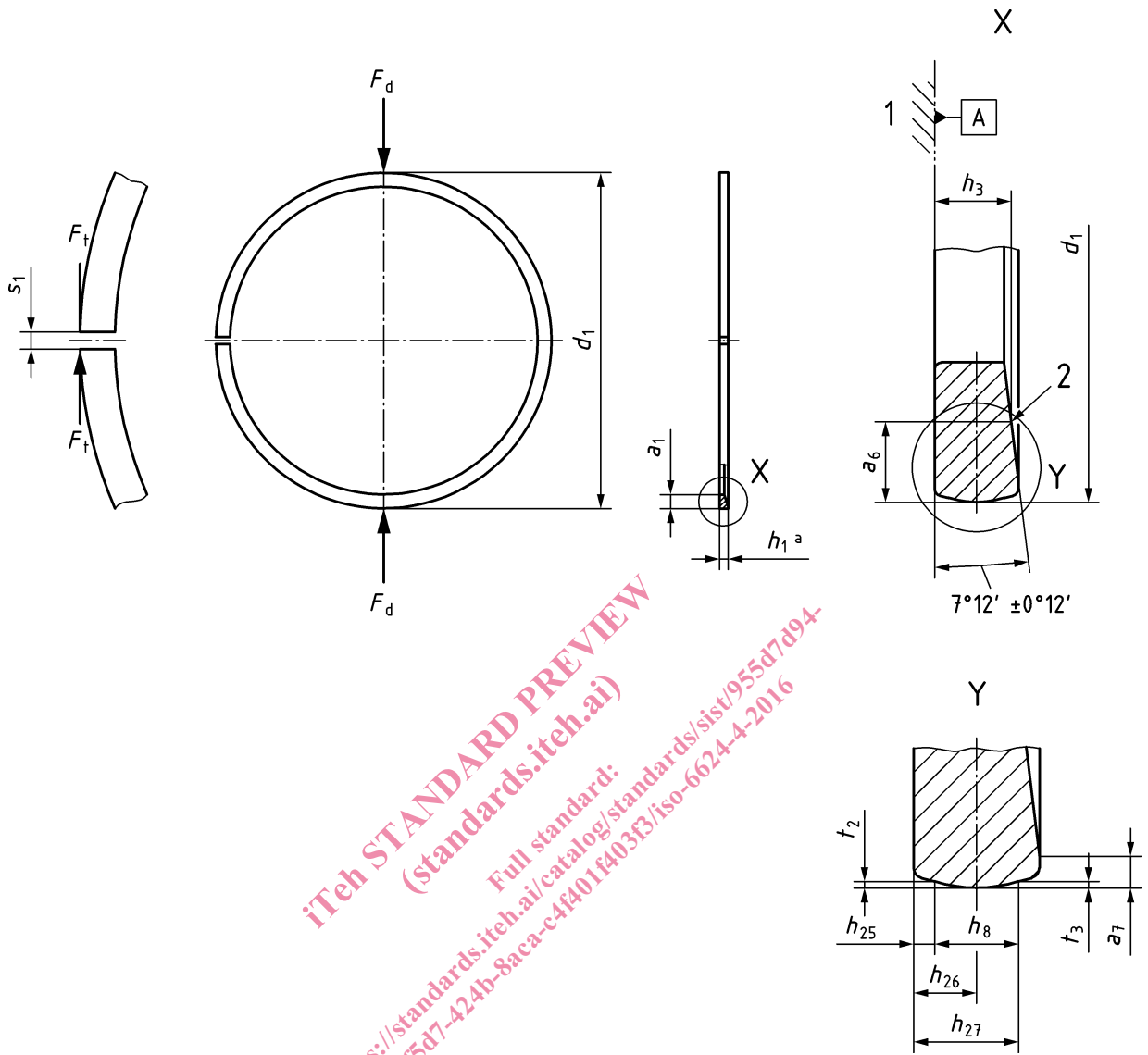

iTeh STANDARD PREVIEW
 (standards.iteh.ai)
 Full standard:
<https://standards.iteh.ai/catalog/standards/sist/955d7d94-f5d7-424b-8aca-c4f401f403f3/iso-6624-4-2016>

Key

- 1 reference plane
- 2 top side identification mark
- a Nominal.
- b $t = 0,006 \times h_1$.

Figure 2 — Type HKB

Table 1 — Symmetrical barrel dimensions and gauge width (h_8)

Dimensions in millimetres

h_1	h_{25}	h_{26}	h_{26} tol.	h_{27}	t_2, t_3	h_8^a
1,2	0,30	0,60	± 0,20	0,90	0,002...0,012	0,60
1,5	0,35	0,75	± 0,25	1,15	0,003...0,015	0,80
1,75	0,35	0,85	± 0,30	1,35		1,00
2,0	0,40	1,00	± 0,30	1,60		1,20
2,5	0,45	1,25	± 0,40	2,05		1,60
3,0	0,50	1,50	± 0,50	2,50	0,005...0,020	2,00
3,5	0,55	1,75	± 0,50	2,95		2,40

^a Gauge width (h_8) only informative; may be used only if agreed between manufacturer and customer.

4.2.2 Designation

EXAMPLE Designation of a piston ring complying with the requirements of ISO 6624-4, being a half keystone ring made of steel with a barrel faced peripheral surface (HKB), of nominal diameter $d_1 = 60$ mm (60), of nominal ring width $h_1 = 1,5$ mm (1,5), made of martensitic steel 11%Cr (min.) subclass 65 (MC65), and nitrided on the peripheral surface and side faces (NT) to a depth of 0,050 mm min. on the peripheral surface (050), with an associated side face depth of 0,015 mm min.:

Piston ring ISO 6624-4 HKB - 60×1,5 - MC65/NT050

4.3 Type HKBA — Asymmetrical Barrel faced half keystone ring 7° (not recommended for nitrided rings of code NT)

4.3.1 General features

See Table 7 for dimensions and forces.

h_3 values are calculated based on $h_1 + 0,05$ mm.