**Adhesives — Test methods for
isotropic electrically conductive
adhesives —**

Part 4:
**Determination of shear strength and
electrical resistance using rigid-to-
rigid bonded assemblies**

iTeh STANDARD PREVIEW
(standards.iteh.ai)

*Adhésifs — Méthodes d'essai pour adhésifs à conductivité électrique
isotrope* 16525-4:2014

<https://standards.iteh.org/catalog/standards/sist/e58527b8-74e8-46a7-a5aa-c347dce2d53d/iso-16525-4-2014>
*Partie 4: Détermination de la résistance au cisaillement et de la
résistance électrique des assemblages collés rigide sur rigide*



iTeh STANDARD PREVIEW
(standards.iteh.ai)

ISO 16525-4:2014

<https://standards.iteh.ai/catalog/standards/sist/e58527e8-74e8-46a7-a5aa-c347dce2d53d/iso-16525-4-2014>



COPYRIGHT PROTECTED DOCUMENT

© ISO 2014

All rights reserved. Unless otherwise specified, no part of this publication may be reproduced or utilized otherwise in any form or by any means, electronic or mechanical, including photocopying, or posting on the internet or an intranet, without prior written permission. Permission can be requested from either ISO at the address below or ISO's member body in the country of the requester.

ISO copyright office
Case postale 56 • CH-1211 Geneva 20
Tel. + 41 22 749 01 11
Fax + 41 22 749 09 47
E-mail copyright@iso.org
Web www.iso.org

Published in Switzerland

Contents

	Page
Foreword	iv
1 Scope	1
2 Normative references	1
3 Terms and definitions	1
4 Apparatus and materials	2
5 Specimen	2
6 Tests	3
6.1 Atmospheric conditions	3
6.2 Procedure	3
7 Test report	4
Annex A (normative) Apparatus for shear strength tests	5
Annex B (normative) Procedure of shear strength tests	7
Bibliography	9

iTeh STANDARD PREVIEW (standards.iteh.ai)

[ISO 16525-4:2014](https://standards.iteh.ai/catalog/standards/sist/e58527e8-74e8-46a7-a5aa-c347dce2d53d/iso-16525-4-2014)

<https://standards.iteh.ai/catalog/standards/sist/e58527e8-74e8-46a7-a5aa-c347dce2d53d/iso-16525-4-2014>

Foreword

ISO (the International Organization for Standardization) is a worldwide federation of national standards bodies (ISO member bodies). The work of preparing International Standards is normally carried out through ISO technical committees. Each member body interested in a subject for which a technical committee has been established has the right to be represented on that committee. International organizations, governmental and non-governmental, in liaison with ISO, also take part in the work. ISO collaborates closely with the International Electrotechnical Commission (IEC) on all matters of electrotechnical standardization.

The procedures used to develop this document and those intended for its further maintenance are described in the ISO/IEC Directives, Part 1. In particular the different approval criteria needed for the different types of ISO documents should be noted. This document was drafted in accordance with the editorial rules of the ISO/IEC Directives, Part 2. www.iso.org/directives

Attention is drawn to the possibility that some of the elements of this document may be the subject of patent rights. ISO shall not be held responsible for identifying any or all such patent rights. Details of any patent rights identified during the development of the document will be in the Introduction and/or on the ISO list of patent declarations received. www.iso.org/patents

Any trade name used in this document is information given for the convenience of users and does not constitute an endorsement.

The committee responsible for this document is ISO/TC 61, *Plastics*, Subcommittee SC 11, *Products*.

ISO 16525 consists of the following parts, under the general title *Adhesives — Test methods for isotropic electrically conductive adhesives*:

- Part 1: *General test methods*
- Part 2: *Determination of electric characteristics for use in electronic assemblies*
- Part 3: *Determination of heat-transfer properties*
- Part 4: *Determination of shear strength and electrical resistance using rigid-to-rigid bonded assemblies*
- Part 5: *Determination of shear fatigue*
- Part 6: *Determination of pendulum-type shear impact*
- Part 7: *Environmental test methods*
- Part 8: *Electrochemical migration test methods*
- Part 9: *Determination of high-speed signal-transmission characteristics*

Adhesives — Test methods for isotropic electrically conductive adhesives —

Part 4:

Determination of shear strength and electrical resistance using rigid-to-rigid bonded assemblies

SAFETY STATEMENT — Persons using this part of ISO 16525 should be familiar with normal laboratory practice. This part of ISO 16525 does not purport to address all of the safety problems, if any, associated with its use. It is the responsibility of the user to establish appropriate safety and health practices and to ensure compliance with any regulatory conditions.

IMPORTANT — Certain procedures specified in this part of ISO 16525 might involve the use or generation of substances, or the generation of waste, that could constitute a local environmental hazard. Reference should be made to appropriate documentation on safe handling and disposal after use.

1 Scope

This part of ISO 16525 specifies test methods using miniature specimens to determine shear strength and electrical resistance of a bonded joint that consists of isotropic electrically conductive adhesives and rigid adherends in specified conditions.

2 Normative references

The following documents, in whole or in part, are normatively referenced in this document and are indispensable for its application. For dated references, only the edition cited applies. For undated references, the latest edition of the referenced document (including any amendments) applies.

ISO 291, *Plastics — Standard atmospheres for conditioning and testing*

ISO 431, *Copper refinery shapes*

ISO 472, *Plastics — Vocabulary*

ISO 10365, *Adhesives — Designation of main failure patterns*

ISO 17212, *Structural adhesives — Guidelines for the surface preparation of metals and plastics prior to adhesive bonding*

3 Terms and definitions

For the purposes of this document, the terms and definitions in ISO 472 and the following apply.

3.1

displacement rate

crosshead speed of the test machine, i.e. a jig, which applies the load to the isotropic electrically conductive adhesive layer during the shear strength test

4 Apparatus and materials

4.1 Apparatus for shear fatigue tests, consisting of a tensile machine, a specimen-holder jig, an ohmmeter, and a recorder. The specifications shall comply with the specifications of test apparatus specified in [Annex A](#).

4.2 Ohmmeter, to measure the electrical resistance of the specimens, based on the drop of potential method (four-terminal operation) or the equivalent.

4.3 Shearing jig, for shear strength testing of specimens, as specified in [Annex A](#), unless otherwise specified in the product specifications.

4.4 Stereoscopic microscope, magnification from 50x to 250x with a light that illuminates the specimen at luminance around 2 000 lx.

4.5 Adherend, class 2 oxygen-free copper as specified in ISO 431, unless otherwise specified in the product specifications.

5 Specimen

Use a specimen that is equal in form and dimensions with the adherend, as shown in [Figure 1](#).

If the dimensions of the specimen are different from those shown in [Figure 1](#), interpretation of results might be difficult because adhesion strength cannot be compared.

Bonding of the adherend using an isotropic electrically conductive adhesive shall be undertaken as follows.

- ISO 16525-4:2014
<https://standards.iteh.ai/catalog/standards/sig/e58527e8-74e8-46a7-a5aa-c347dce2d53d/iso-16525-4-2014>
- a) Treat the surface to be bonded in accordance with manufacturer's instructions or ISO 17212. Report the method of surface treatment.
 - b) Join a lead wire to the end face of the adherend to measure electrical resistance.
 - c) Apply the isotropic electrically conductive adhesive to the adherend. Fix and bond them so that the thickness of the joint equals the dimension shown in [Figure 1](#). For application and the curing of the adhesives, follow the adhesive manufacturer's recommendations. If the product specifications do not refer to curing, carry out curing at 150 °C for 30 min in the atmosphere.
 - d) Use a jig to maintain the gap and alignment between the copper rods when bonding.

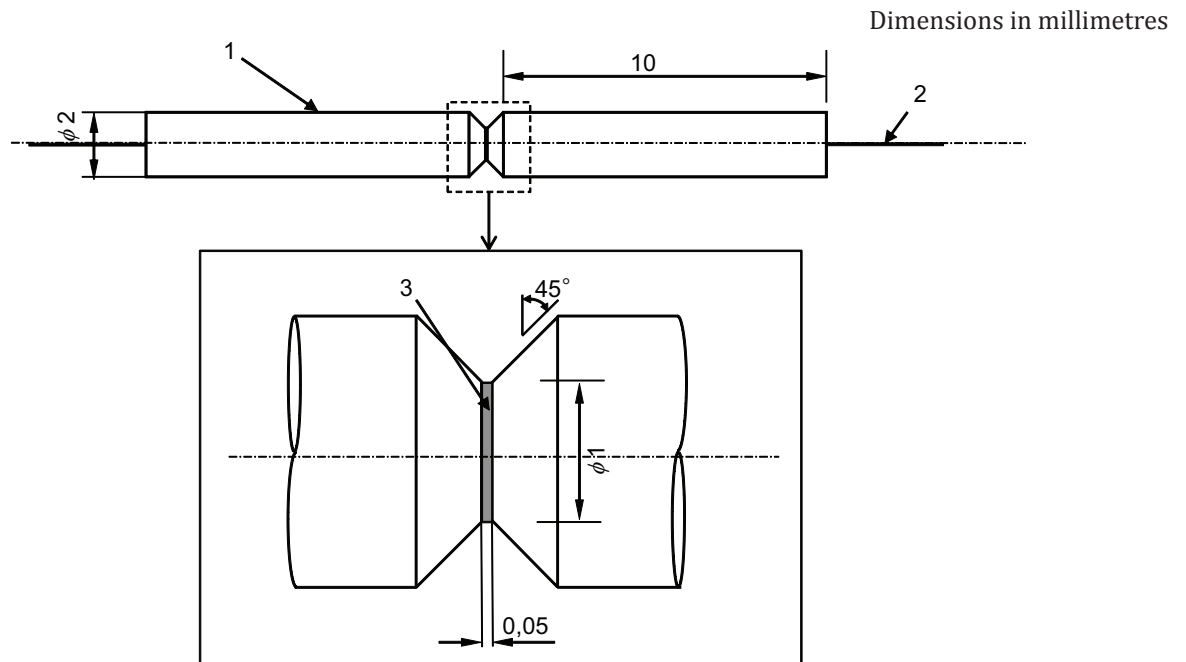
**Key**

- 1 copper rod
- 2 copper wire
- 3 conductive adhesive

iTeh STANDARD PREVIEW
(standards.iteh.ai)

Figure 1 — Miniature joint specimen

ISO 16525-4:2014

<https://standards.iteh.ai/catalog/standards/sist/e58527e8-74e8-46a7-a5aa-c347dce2d53d/iso-16525-4-2014>

6 Tests

6.1 Atmospheric conditions

Where possible, use the test atmospheric conditions specified in ISO 291. If alternative atmospheric conditions are used (upon mutual agreement between the delivering and receiving parties), record the temperature and humidity used in the test report.

6.2 Procedure

After the pretreatment, observe the bonded portions; using a stereoscopic microscope specified in 4.4, check that there are no cracks or defects. Then, follow the procedure below unless otherwise specified. Details of the test procedure for measuring the shear strength of an assembly bonded with an isotropic electrically conductive adhesive are given in Annex B.

- a) Fix the specimen to the fixing jig and connect it to the ohmmeter.
- b) Set a rate of loading (or displacement rate) and test temperature.
- c) Continue the shear test until a fracture is detected, record the shear force and electrical resistance, and calculate the shear strength.
- d) Observe the fracture, if necessary, to confirm and record the fracture mode in accordance with ISO 10365.

7 Test report

The test report shall contain the following items. Some items may be selected from items b) through l) upon agreement between the delivering and receiving parties:

- a) a reference to this part of ISO 16525, i.e. ISO 16525-4;
- b) the name of the isotropic electrically conductive adhesive and its data, including kinds of resin, filler material, manufacturer's code and lot number;
- c) requirements of the adherend, including material and surface treatment;
- d) application method of the isotropic electrically conductive adhesive, curing time or setting time, temperature and pressure of the adhesive procedure;
- e) dimensions of the specimens, and the form and dimensions of the adhesive layer after bonding;
- f) model numbers of the shear strength test apparatus and ohmmeter;
- g) details of fixation of specimens (illustration preferred);
- h) adjustment of the pretest conditions and test atmospheric conditions;
- i) the displacement rate or the rate of loading, if load-controlled testing is carried out;
- j) shear strength and electrical resistance of specimens;
- k) modes of fracture after the test in accordance with ISO 10365;
- l) the date, institution and atmospheric conditions of the test.

ISO 16525-4:2014
<https://standards.iteh.ai/catalog/standards/sist/e58527e8-74e8-46a7-a5aa-c347dce2d53d/iso-16525-4-2014>

Annex A (normative)

Apparatus for shear strength tests

A.1 General

This annex specifies the apparatus for shear strength testing of specimens specified in [4.1](#), and specifies its detailed requirements.

A.2 Apparatus for shear strength tests

A.2.1 Apparatus for tensile tests

For the measurement of shear strength, use apparatus that meets the following requirements unless otherwise specified in the product specifications.

- a) The displacement rate with respect to the specimen jig shall be constant.

The test apparatus should preferably be equipped with a linear DC motor or piezoelectric actuator so that displacement can be controlled within the micro-meter range.

- b) Maintain constant displacement in the vicinity of the specimen using a displacement detector installed on the specimen jig. The displacement detector should preferably have noncontact eddy current and capacitance to avoid influencing the shear force.
- c) The test apparatus should have a load indicator to measure and record the force of reaction, which is generated by the shearing deformation of the adhesive layer during test.
- d) Choose a load indicator that makes it possible to break the microscopic specimen in the range from 10 % to 80 % of the full capacity, so that the adhesion of the miniature specimen can be measured precisely.
- e) When increasing temperature for the test, the test apparatus should be able to control the temperature.

A.2.2 Shearing jig, having a structure that can fix the specimen and apply shear strain to the bonded portion by mechanical displacement.

The structure of shear jig should preferably be able to secure the adherend. The fixing jig should be designed so that the line of force is located at the centre of the specimen to inhibit bending deformation. [Figure A.1](#) shows an example of a fixing jig.