

---

---

**Adhesives — Test methods for  
isotropic electrically conductive  
adhesives —**

**Part 5:  
Determination of shear fatigue**

**iTeh STANDARD PREVIEW**  
*Adhésifs — Méthodes d'essai pour adhésifs à conductivité électrique  
isotrope —*  
**(standards.iteh.ai)**  
*Partie 5: Détermination de la fatigue par cisaillement*

[ISO 16525-5:2014](https://standards.iteh.ai/catalog/standards/sist/63d9d1ac-82be-4d11-a5fb-2df2285add69/iso-16525-5-2014)

[https://standards.iteh.ai/catalog/standards/sist/63d9d1ac-82be-4d11-a5fb-  
2df2285add69/iso-16525-5-2014](https://standards.iteh.ai/catalog/standards/sist/63d9d1ac-82be-4d11-a5fb-2df2285add69/iso-16525-5-2014)



**iTeh STANDARD PREVIEW**  
**(standards.iteh.ai)**

ISO 16525-5:2014

<https://standards.iteh.ai/catalog/standards/sist/63d9d1ac-82be-4d11-a5fb-2df2285add69/iso-16525-5-2014>



**COPYRIGHT PROTECTED DOCUMENT**

© ISO 2014

All rights reserved. Unless otherwise specified, no part of this publication may be reproduced or utilized otherwise in any form or by any means, electronic or mechanical, including photocopying, or posting on the internet or an intranet, without prior written permission. Permission can be requested from either ISO at the address below or ISO's member body in the country of the requester.

ISO copyright office  
Case postale 56 • CH-1211 Geneva 20  
Tel. + 41 22 749 01 11  
Fax + 41 22 749 09 47  
E-mail [copyright@iso.org](mailto:copyright@iso.org)  
Web [www.iso.org](http://www.iso.org)

Published in Switzerland

# Contents

	Page
Foreword .....	iv
<b>1 Scope</b> .....	<b>1</b>
<b>2 Normative references</b> .....	<b>1</b>
<b>3 Terms and definitions</b> .....	<b>1</b>
<b>4 Apparatus and materials</b> .....	<b>2</b>
<b>5 Specimen</b> .....	<b>2</b>
<b>6 Tests</b> .....	<b>3</b>
6.1 Atmospheric conditions .....	3
6.2 Procedure .....	3
6.3 Judgment .....	4
<b>7 Test report</b> .....	<b>4</b>
<b>Annex A (normative) Apparatus for shear fatigue tests</b> .....	<b>5</b>
<b>Annex B (normative) Procedure of shear fatigue tests</b> .....	<b>7</b>
<b>Bibliography</b> .....	<b>11</b>

## iTeh STANDARD PREVIEW (standards.iteh.ai)

[ISO 16525-5:2014](https://standards.iteh.ai/catalog/standards/sist/63d9d1ac-82be-4d11-a5fb-2df2285add69/iso-16525-5-2014)

<https://standards.iteh.ai/catalog/standards/sist/63d9d1ac-82be-4d11-a5fb-2df2285add69/iso-16525-5-2014>

## Foreword

ISO (the International Organization for Standardization) is a worldwide federation of national standards bodies (ISO member bodies). The work of preparing International Standards is normally carried out through ISO technical committees. Each member body interested in a subject for which a technical committee has been established has the right to be represented on that committee. International organizations, governmental and non-governmental, in liaison with ISO, also take part in the work. ISO collaborates closely with the International Electrotechnical Commission (IEC) on all matters of electrotechnical standardization.

The procedures used to develop this document and those intended for its further maintenance are described in the ISO/IEC Directives, Part 1. In particular the different approval criteria needed for the different types of ISO documents should be noted. This document was drafted in accordance with the editorial rules of the ISO/IEC Directives, Part 2. [www.iso.org/directives](http://www.iso.org/directives)

Attention is drawn to the possibility that some of the elements of this document may be the subject of patent rights. ISO shall not be held responsible for identifying any or all such patent rights. Details of any patent rights identified during the development of the document will be in the Introduction and/or on the ISO list of patent declarations received. [www.iso.org/patents](http://www.iso.org/patents)

Any trade name used in this document is information given for the convenience of users and does not constitute an endorsement.

Any trade name used in this document is information given for the convenience of users and does not constitute an endorsement.

For an explanation on the meaning of ISO specific terms and expressions related to conformity assessment, as well as information about ISO's adherence to the WTO principles in the Technical Barriers to Trade (TBT) see the following URL: Foreword - Supplementary information

The committee responsible for this document is ISO/TC 61, Plastics, Subcommittee SC 11, Products.

ISO 16525 consists of the following parts, under the general title *Adhesives — Test methods for isotropic electrically conductive adhesives*:

- Part 1: General test methods
- Part 2: Determination of electric characteristics for use in electronic assemblies
- Part 3: Determination of heat-transfer properties
- Part 4: Determination of shear strength and electrical resistance using rigid-to-rigid bonded assemblies
- Part 5: Determination of shear fatigue
- Part 6: Determination of pendulum-type shear impact
- Part 7: Environmental test methods
- Part 8: Electrochemical-migration test methods
- Part 9: Determination of high-speed signal-transmission characteristics

# Adhesives — Test methods for isotropic electrically conductive adhesives —

## Part 5: Determination of shear fatigue

**SAFETY STATEMENT** — Persons using this part of ISO 16525 should be familiar with normal laboratory practice. This part of ISO 16525 does not purport to address all of the safety problems, if any, associated with its use. It is the responsibility of the user to establish appropriate safety and health practices and to ensure compliance with any regulatory conditions.

**IMPORTANT** — Certain procedures specified in this part of ISO 16525 might involve the use or generation of substances, or the generation of waste, that could constitute a local environmental hazard. Reference should be made to appropriate documentation on safe handling and disposal after use.

### 1 Scope

This part of ISO 16525 specifies test methods using miniature specimens to measure shear fatigue of a glued joint that consists of isotropic electrically conductive adhesives and rigid adherends in specified conditions.

### 2 Normative references

The following documents, in whole or in part, are normatively referenced in this document and are indispensable for its application. For dated references, only the edition cited applies. For undated references, the latest edition of the referenced document (including any amendments) applies.

ISO 291, *Plastics — Standard atmospheres for conditioning and testing*

ISO 431, *Copper refinery shapes*

ISO 472, *Plastics — Vocabulary*

ISO 10365, *Adhesives — Designation of main failure patterns*

ISO 17212, *Structural adhesives — Guidelines for the surface preparation of metals and plastics prior to adhesive bonding*

### 3 Terms and definitions

For the purposes of this document, the terms and definitions in ISO 472 and the following apply.

#### 3.1

##### **shear fatigue life**

number of cycles of shear strain applied to the test specimen until adhesion layer failure is observed

#### 3.2

##### **maximum load**

force generated through shear deformation of the specimen at the maximum test positions in each cycle

**3.3  
minimum load**

force generated through shear deformation of the specimen at the minimum test positions in each cycle

**3.4  
displacement range**

distance between the actuator's maximum and minimum positions

**3.5  
shear strain**

shear strain is determined, dividing shear displacement by thickness of the adhesive layer

Note 1 to entry: Displacement measured by the test apparatus is not consistent with shear displacement of the adhesive layer, containing deformation of both the adherend and the test apparatus. Therefore, determine the rigidity of both the adherend and the test apparatus in advance, and take deformation of both the adherend and the test apparatus into account when calculating test results.

**3.6  
shear strain range**

algebraic sum of maximum shear strain and minimum shear strain generated in the isotropic electrically conductive adhesive layer

**3.7  
non-linear shear strain range**

algebraic sum of the maximum non-linear shear strain and minimum non-linear shear strain generated in the isotropic electrically conductive adhesive layer, equivalent to the maximum width at zero stress of the cyclic shear stress-shear strain curve in a cycle

**3.8  
displacement rate**

crosshead speed of the test machine, i.e. a jig, that applies the load to the isotropic electrically conductive adhesive layer during the shear strength test

ITEH STANDARD PREVIEW  
(standards.iteh.ai)

## 4 Apparatus and materials

**4.1 Apparatus for shear strength tests**, consisting of a tensile machine, a specimen-holder jig, an ohmmeter, and a recorder. The specifications shall comply with the specifications of test apparatus specified in [Annex A](#).

**4.2 Ohmmeter**, to measure electrical resistance of specimens, based on the fall-of-potential method (four-terminal operation) or equivalent.

**4.3 Shearing jig**, for shear strength testing of specimens, as specified in [Annex A](#), unless otherwise specified in the product specifications.

**4.4 Stereoscopic microscope**, with magnification from 50x to 250x or so and with a light that illuminates the specimen at luminance around 2 000 lx.

**4.5 Adherend**, class-2 oxygen-free copper as specified in ISO 431, unless otherwise specified in the product specifications.

## 5 Specimen

Use a specimen that is consistent with the adherend in form and dimensions, as shown in [Figure 1](#).

NOTE If the dimensions of the specimen are different from those shown in [Figure 1](#), interpretation of results might be difficult because adhesion strength cannot be directly compared.

Bonding of the adherend using an isotropic electrically conductive adhesive shall be undertaken as follows.

- a) Treat the surface to be bonded in accordance with manufacturer's instructions or ISO 17212. Report the method of surface treatment.
- b) Join a lead wire to the end face of the adherend to measure electrical resistance.
- c) Apply the isotropic electrically conductive adhesive to the adherend. Fix and bond them so that the thickness of the joint is equal to the dimension shown in [Figure 1](#). For application and the curing of the adhesives, follow the adhesive manufacturer's recommendations.
- d) Use a jig to maintain the gap and alignment between the copper rods when bonding.

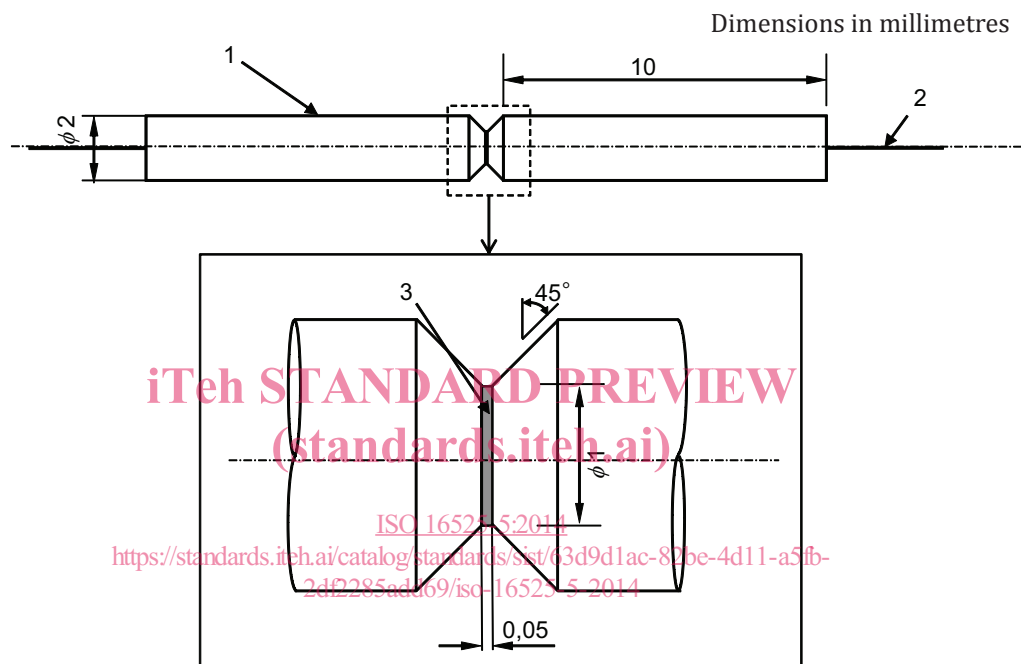

#### Key

- 1 copper rod
- 2 copper wire
- 3 conductive adhesive

**Figure 1 — Miniature joint specimen**

## 6 Tests

### 6.1 Atmospheric conditions

Where possible, use the test atmospheric conditions specified in ISO 291. If alternative atmospheric conditions are used upon mutual agreement between the delivering and receiving parties, record the temperature and humidity used in the test report.

### 6.2 Procedure

After the pretreatment, observe the adhesive layer, using a stereoscopic microscope specified in [4.4](#) to check that there are no cracks or defects. Then, follow the procedure below unless otherwise specified.

Details of the test procedure for measuring the shear strength of an assembly bonded with an isotropic electrically conductive adhesive are given in [Annex B](#).

- a) Fix the specimen to the fixing jig and connect it to the ohmmeter.
- b) Set a rate of loading (or displacement rate) and test temperature.
- c) Continue the fatigue test until a fracture is detected and record changes in the maximum shear force, electrical resistance, and shear fatigue life.
- d) Observe the fracture, if necessary, to confirm and record the fracture mode.

### 6.3 Judgment

The specimen is judged to have reached its fatigue life when the maximum shear load has decreased to a specific value, for example, 20 % from the initial value, or the electrical resistance has increased to a specific value, for example, 20 % from the initial value. Note that the shear force is influenced by changes in the resin characteristics due to heating. Therefore, when increasing temperature to or higher than the glass transition point during a test, it is preferable to use electrical resistance to judge the specimen's fatigue life.

## 7 Test report

The test report shall contain the following items. Some items may be selected from items b) to m) upon agreement between the delivering and receiving parties.

- a) a reference to this part of ISO 16525, i.e. ISO 16525-5;
- b) the name of the isotropic electrically conductive adhesive and its data, including kinds of resin, filler material, manufacturer's code and lot number;
- c) requirements of the adherend, including material and surface treatment;
- d) application method of the isotropic electrically conductive adhesive, curing time or setting time, temperature, and pressure of the adhesive procedure;
- e) dimensions of the specimens and the form and dimensions of the adhesive layer after bonding;
- f) model numbers of the shear fatigue test apparatus and ohmmeter;
- g) details of fixation of specimens (illustration preferred);
- h) any adjustment of the pretest conditions and test atmospheric conditions;
- i) the displacement rate and test temperature;
- j) the displacement range or shear strain range;
- k) the number of cycles to failure and electrical resistance;
- l) modes of fracture after the test in accordance with ISO 10365;
- m) the date, institution and atmospheric conditions of the test.



## Annex A (normative)

### Apparatus for shear fatigue tests

#### A.1 General

This annex specifies the apparatus for shear fatigue testing of specimens specified in [Clause 4](#), and specifies its detailed requirements.

#### A.2 Apparatus for shear fatigue tests

##### A.2.1 Apparatus for fatigue tests

For fatigue tests, use apparatus meeting the following requirements unless otherwise specified in the product specifications:

- a) having a function of moving the specimen-fixing jig, using ramp waves;

The test apparatus should preferably be equipped with a linear DC motor or piezoelectric actuator, so that displacement can be controlled within the micrometer range.

The test apparatus should preferably be able to control sine and trapezoidal waves, in addition to ramp waves, because tests using sine or trapezoidal waves instead of ramp waves are also effective.

- b) having functions of measuring displacement in the vicinity of the specimen using a displacement detector installed to the specimen fixing jig. Do not use the displacement detector in the actuator and feedback control of the actuator using the measured displacement. The displacement detector should preferably be a noncontact eddy current type and a capacitance type to avoid influencing the shear force;
- c) preferably having a load indicator to measure and record the force of reaction, which is generated by shearing deformation of the adhesive layer during a test;
- d) having a load indicator, which should be able to measure decreases in the force of reaction, which is generated due to deterioration (initiation and propagation of a crack) of the bonded portion;
- e) when increasing temperature for the test, the test apparatus should preferably be able to control temperature.

**A.2.2 Shearing jig**, having a structure, which can fix the specimen and apply shear strain to the bonded portion by mechanical displacement.

The structure of the shearing jig should preferably be able to secure the adherend. The fixing jig should be designed so that the line of force is located at the centre of the specimen to inhibit bending deformation. [Figure A.1](#) shows an example of a fixing jig.