



Standard Test Methods for Hydrogen Content of Light Distillates, Middle Distillates, Gas Oils, and Residua by Low-Resolution Nuclear Magnetic Resonance Spectroscopy¹

This standard is issued under the fixed designation D 4808; the number immediately following the designation indicates the year of original adoption or, in the case of revision, the year of last revision. A number in parentheses indicates the year of last reapproval. A superscript epsilon (ϵ) indicates an editorial change since the last revision or reapproval.

This standard has been approved for use by agencies of the Department of Defense.

1. Scope*

1.1 These test methods cover the determination of the hydrogen content of petroleum products ranging from atmospheric distillates to vacuum residua using a continuous wave, low-resolution nuclear magnetic resonance spectrometer. (Test Method D 3701 is the preferred method for determining the hydrogen content of aviation turbine fuels using nuclear magnetic resonance spectroscopy.)

1.2 Three test methods are included here that account for the special characteristics of different petroleum products and apply to the following distillation ranges:

Test Method	Petroleum Products	Boiling Range, °C (°F) (approximate)
A	Light Distillates	15–260 (60–500)
B	Middle Distillates, Gas Oils	200–370 (400–700)
C	Residua	370–510 (700–950) 510+ (950+)

1.3 The preferred units are mass %.

1.4 *This standard does not purport to address all of the safety concerns, if any, associated with its use. It is the responsibility of the user of this standard to establish appropriate safety and health practices and determine the applicability of regulatory limitations prior to use.* For specific hazard statements, see Section 6.1.

2. Referenced Documents

2.1 ASTM Standards:

D 3701 Test Method for Hydrogen Content of Aviation Turbine Fuels by Low Resolution Nuclear Magnetic Resonance Spectrometry²

D 4057 Practice for Manual Sampling of Petroleum and Petroleum Products²

¹ This test method is under the jurisdiction of ASTM Committee D02 on Petroleum Products and Lubricants and is the direct responsibility of Subcommittee D02.03 on Elemental Analysis.

Current edition approved Nov. 10, 2001. Published December 2001. Originally published as D 4808 – 88. Last previous edition D 4808 – 98.

² Annual Book of ASTM Standards, Vol 05.02.

D 5291 Test Methods for Instrumental Determination of Carbon, Hydrogen, and Nitrogen in Petroleum Products and Lubricants²

3. Summary of Test Methods

3.1 A test specimen is compared in a continuous wave, low-resolution nuclear magnetic resonance (NMR) spectrometer with a reference standard sample. The spectrometer records in a nondestructive fashion the absolute concentration of hydrogen atoms in the reference standard and test sample. The absolute hydrogen concentrations reported by the integrator on the NMR instrument for the standard and test specimens are used as a means of comparing the theoretical hydrogen content of the standard with that of the sample, the result being expressed as the hydrogen content (on a mass % basis) of the sample.

3.2 To ensure an accurate measure of the absolute hydrogen content of the reference standard and sample, it is necessary to ensure that the measured hydrogen integrator counts are always directly proportional to the absolute hydrogen content of the standard and sample.

3.3 Undercounting of the reference standard with respect to the sample is avoided in Test Methods B and C by dilution of the standard with a relaxation reagent solution. Undercounting of highly viscous or solid test samples is avoided by dissolving the sample in a non-hydrogen containing solvent, which ensures that all of the weighed sample is in a fluid and homogeneous solution at the time of measurement. An elevated sample temperature at the time of measurement also ensures a homogeneous liquid-phase sample.

4. Significance and Use

4.1 The hydrogen content represents a fundamental quality of a petroleum product that has been correlated with many of the performance characteristics of that product.

4.2 This test method provides a simple and more precise alternative to existing test methods, specifically combustion techniques (Test Method D 5291) for determining the hydrogen content on a range of petroleum products.

*A Summary of Changes section appears at the end of this standard.

5. Apparatus

NOTE 1—This test method has been written around the Newport Analyzer Mark III F or its replacement version, the Newport 4000 (Oxford Analytical Instruments, Ltd., Oxford, England), and the details of the test method are to be read in conjunction with the manufacturer's handbook. These instruments have demonstrated statistically indistinguishable performance in these standard methods and in Test Method D 3701. Any similar instrument is acceptable, provided that the new instrument is adequately correlated and proved to be statistically similar. As of the mid-1990's however, the Newport 4000 instrument is no longer being manufactured by the vendor. No newer models are currently being manufactured as replacements for the Newport 4000 instrument.

5.1 Nuclear Magnetic Resonance Spectrometer:

5.1.1 A low-resolution, continuous wave instrument capable of measuring a nuclear magnetic resonance signal due to hydrogen atoms in the sample and includes an excitation and detection coil of suitable dimensions to contain the test cell; an electronic unit, to control and monitor the magnet and coil, and containing: circuits, to control and adjust the radio-frequency level and audio-frequency gain; and integrating counter, with variable time period in seconds.

5.1.2 Test Methods B and C also require that the instrument has the ability to equilibrate samples within the probe at an elevated temperature (50°C).

5.2 *Conditioning Block*—A block of aluminum alloy drilled with holes of sufficient size to accommodate the test cells with the mean height of the sample being at least 20 mm below the top of the conditioning block, capable of holding the sample at the given test temperature (see Fig. 1).

5.3 *Test Cells*—Nessler-type tubes of approximately 100-mL capacity with a nominal external diameter of 34 mm and a nominal internal diameter of 31 mm marked at a distance of 51 mm above the bottom of the tube by a ring around the circumference. The variation between the internal diameters of the test cells used for the sample and reference material should not be greater than ± 0.5 mm.

NOTE 2—To avoid potential difficulties with tightness when the test cell is introduced into the magnet coil, users are cautioned to avoid test cells that have nominal external diameters that are greater than 34.2 mm.

5.4 *Polytetrafluoroethylene (PTFE) Plugs*, for closing the test cells and made from pure PTFE.

5.5 *Insertion Rod*—A metal rod with a threaded end used for inserting and removing the PTFE plugs from the test cells (see Fig. 1).

5.6 *Analytical Balance*—A top pan-type balance, capable of weighing the test cells in an upright position to an accuracy of at least 0.001 g.

5.7 *Beakers*, 150 mL and 50 mL with pour spouts.

5.8 *Glass Stirring Rod*, approximately 250-mm length.

6. Reagents and Materials

6.1 *Purity of Reagents*—Reagent grade chemicals shall be used in all tests. Unless otherwise indicated, it is intended that all reagents shall conform to the specifications of the Committee on Analytical Reagents of the American Chemical Society,

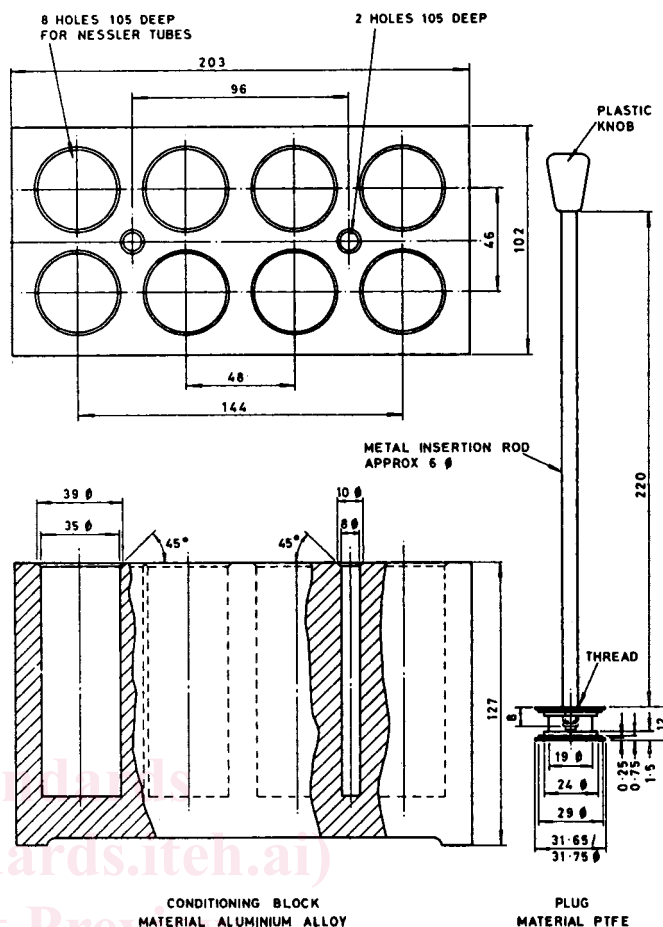

FIG. 1 Conditioning Block and Insertion Rod

where such specifications are available.³ Other grades may be used, provided it is first ascertained that the reagent is of sufficiently high purity to permit its use without lessening the accuracy of the determination.

6.2 *Reference Standard—n-Dodecane*. (**Warning**—Flammable.)

6.3 *Relaxation Reagent Solution*, prepared from ferric acetylacetonate ($\text{Fe}(\text{C}_5\text{H}_7\text{O}_2)_3$ - MW = 353.16, reagent grade)—Prepare a fresh 0.02 M $\text{Fe}(\text{C}_5\text{H}_7\text{O}_2)_3$ solution by dissolving 1.77 g of $\text{Fe}(\text{C}_5\text{H}_7\text{O}_2)_3$ in 250 mL TCE. If any of the $\text{Fe}(\text{C}_5\text{H}_7\text{O}_2)_3$ remains undissolved, filter the solution, and use the filtrate in subsequent steps.

6.4 *Tetrachloroethylene (TCE)*. (**Warning**—Cancer-suspect agent.)

7. Sampling

7.1 Take a homogeneous sample in accordance with Practice D 4057. Mix the sample prior to taking a representative aliquot as the test specimen. Middle distillates, gas oils, and

³ *Reagent Chemicals, American Chemical Society Specifications*, American Chemical Society, Washington, DC. For suggestions on the testing of reagents not listed by the American Chemical Society, see *Analar Standards for Laboratory Chemicals*, BDH Ltd., Poole, Dorset, U.K., and the *United States Pharmacopeia and National Formulary*, U.S. Pharmacopoeial Convention, Inc. (USPC), Rockville, MD.