



Designation: F1060–05 ~~Designation: F 1060 – 08~~

Standard Test Method for Thermal Protective Performance of Materials for Protective Clothing for Hot Surface Contact¹

This standard is issued under the fixed designation F 1060; the number immediately following the designation indicates the year of original adoption or, in the case of revision, the year of last revision. A number in parentheses indicates the year of last reapproval. A superscript epsilon (ϵ) indicates an editorial change since the last revision or reapproval.

1. Scope

1.1 This test method is used to measure the thermal insulation of materials used in protective clothing when exposed for a short period of time to a hot surface with a temperature up to 600°F (316°C).

1.2 This test method is applicable to materials used in the construction of protective clothing, including, but not limited to: woven fabrics, knit fabrics, battings, sheet structures, and material composites, intended for use as clothing for protection against exposure to hot surfaces.

1.3 This test method should be used to measure and describe the properties of materials, products, or assemblies in response to heat under controlled laboratory conditions and should not be used to describe or appraise the thermal hazard or fire risk of materials, products, or assemblies under actual exposure conditions.

1.4 The values as stated in SI units are to be regarded as the standard. The values in parentheses are given for information only.

1.5 *This standard does not purport to address all of the safety concerns, if any, associated with its use. It is the responsibility of the user of this standard to establish appropriate safety and health practices and determine the applicability of regulatory limitations prior to use.*

2. Referenced Documents

2.1 *ASTM Standards:*²

D 123 Terminology Relating to Textiles

D 1776 Practice for Conditioning and Testing Textiles

D 4391 Terminology Relating to the Burning Behavior of Textiles

F 1494 Terminology Relating to Protective Clothing

3. Terminology

3.1 *Definitions*—In testing thermal protection clothing material, the response to hot surface contact is indicated by the following descriptive terms:

3.1.1 *charring*—the formation of a carbonaceous residue as the result of pyrolysis or incomplete combustion.

3.1.2 *embrittlement*—the formation of a brittle residue as a result of pyrolysis or incomplete combustion.

3.1.3 *heat flux*—the thermal intensity indicated by the amount of energy transmitted per unit area and per unit time ($\text{cal/cm}^2\text{-s}$ —the thermal intensity indicated by the amount of energy transmitted divided by area and time, $\text{W/m}^2\text{-s}$) ($\text{watts/cm}^2\text{-s}$).

3.1.4 *human tissue heat tolerance (heat tolerance)*—in the testing of thermal protective materials, the amount of thermal energy predicted to cause a pain sensation or a second degree second-degree burn injury in human tissue.

3.1.5 *ignition*—the initiation and continuation of combustion. —the initiation of combustion.

3.1.6 *melting*—a response evidenced by softening of the material, resulting in a nonreversible change. —a material response evidenced by softening of the polymer.

3.1.7 *shrinkage*—a response evidenced by reduction in specimen size. —a decrease in one or more dimensions of an object or material.

3.1.8 *sticking*—a material response evidenced by softening and adherence of the material to the hot surface of itself or another material.

3.1.9 *thermal end point*—in the testing of thermal protective materials, the point at which the sensor response on the recorder chart intersects the human tissue burn tolerance criteria overlay. —in the testing of thermal protective materials, the point where

¹ This test method is under the jurisdiction of ASTM Committee F23 on Personal Protective Clothing and Equipment and is the direct responsibility of Subcommittee F23.80 on Flame and Thermal.

Current edition approved July 1, 2005-2008. Published July 2005-February 2008. Originally approved in 1987. Last previous edition approved in 2004-2005 as F 1060 - 04 ϵ .

² For referenced ASTM standards, visit the ASTM website, www.astm.org, or contact ASTM Customer Service at service@astm.org. For Annual Book of ASTM Standards volume information, refer to the standard's Document Summary page on the ASTM website.

the copper slug calorimeter sensor response (heat energy measured) intersects with a predicted skin burn injury model.

3.2 For all terminology related to protective clothing, see Terminology F 1494.

3.3 For definitions of other textile terms used in this test method, refer to Terminology D 123.

4. Summary of Test Method

4.1 This test method measures the performance of insulative materials. A material is placed in contact with a standard hot surface. The amount of heat transmitted by the material is compared with the human tissue tolerance and the obvious effects of the heat on the material are noted.

4.2 The temperature of the hot surface is measured/controlled with a thermocouple and the heat transmitted by the test specimen is measured with a copper calorimeter. The calorimeter temperature increase is a direct measure of the heat energy received.

4.3 A contact pressure of 3 kPa (0.5 psi) is used to compare material performance under controlled conditions. If a different pressure is chosen to represent a specific use condition, where it is used should be noted under test conditions (13.1.2.3).

4.4 The material performance is determined from the amount of heat transferred by the specimen and the observed effect of the heat exposure on the specimen. The thermal protection is the exposure time required to cause the accumulated heat received by the sensor to equal the heat that will result in a pain sensation (see Table 1) or cause a second degree burn in human tissue (see Table 2), as predicted from comparison of heat transfer data with human tissue heat tolerance curves (see Table 1 and Table 2).

5. Significance and Use

5.1 This test method rates materials intended for use as protective clothing against exposure to hot surfaces, for their thermal insulating properties and their reaction to the test conditions.

5.2 The thermal protection time as determined by this test method relates to the actual end-use performance only to the degree that the end-use exposure is identical to the exposure used in this test method; that is, the hot surface test temperature is the same as the actual end-use temperature and the test pressure is the same as the end-use pressure.

5.2.1 Higher pressures, beyond the 3 kPa (0.5 psi) pressure provided by the calorimeter assembly in this test method shall be permitted to be used in this test method to simulate the conditions of protective clothing use.

5.3 The procedure maintains the specimen in a static, horizontal position under a standard pressure and does not involve movement.

5.4 One of the intended applications for this test method is comparing the relative performance of different materials.

5.5 This test method is limited to short exposure because the model used to predict burn injury is limited to predictions of time-to-burn for up to 30 seconds, and predictions of time-to-pain for up to 50 seconds. The use of this test method for longer hot surface exposures requires a different model for determining burn injury or a different basis for reporting test results.

6. Apparatus

6.1 *General Arrangement*—The arrangement of the individual components of the test apparatus is shown in Fig. 1.

6.1.1 Alternatively, transmit temperature output readings to a data acquisition unit, then computer process to obtain the test result.

6.2 *Hot Plate*—Shall have a flat heated surface with the smallest dimension, a minimum of at least 200 mm (8 in.) and have the ability to achieve a temperature of at least 371°C (700°F) and to permit temperature control within 2.8°C (±5°F).

6.3 *Surface plate*—The flat plate shall be 6.4 mm (¼ in.) thick, 140 by 140 mm (5.5 by 5.5 in.) wide, with a 2.4 mm (¾/32 in.) hole drilled from the edge to the center of the plate (Fig. 2). Use either electrolytic copper or T-1100 aluminum surface plates. The surface plate must be flat, smooth, and free from pits and cavities. (Flatness is indicated by negligible light passing between a straight edge and the plate surface.) Loss of the original mill finish (as judged with the naked eye) or warping, or both, may result in failure to achieve calibration with the reference standard.

6.4 *Sensor*—A copper calorimeter mounted in an insulating block with added weight and constructed as shown in Figs. 3 and 4 with the standard characteristics listed below. The following equations permit the determination of the total incident heat energy from the copper calorimeter:

TABLE 1 Human Tissue Tolerance to Pain Sensation

Exposure Time	Heat Flux		Total Heat		Calorimeter Equivalent		
	cal/cm ² -sec	W/cm ²	cal/cm ² -s	W sec/cm ²	ΔT°, F	ΔT°, C	ΔmV
1.0	0.640	2.70	0.640	2.70	8.53	4.74	0.250
1.5	0.475	2.00	0.713	3.00	9.51	5.28	0.275
2.0	0.385	1.61	0.770	3.22	10.27	5.71	0.293
3.0	0.280	1.17	0.840	3.51	11.20	6.22	0.322
5.0	0.195	0.82	0.975	4.08	13.00	7.22	0.375
7.0	0.155	0.65	1.085	4.54	14.47	8.04	0.420
10.0	0.118	0.49	1.180	4.94	15.73	8.74	0.458
20.0	0.076	0.32	1.520	6.36	20.27	11.26	0.582
30.0	0.060	0.25	1.800	7.53	24.00	13.33	0.690
50.0	0.060	0.25	3.000	12.55	40.00	22.22	1.150

TABLE 2 Human Tissue^A Tolerance to Second Degree Burn

Exposure Time, s	Heat Flux		Total Heat		Calorimeter ^B		Equivalent, ΔmV
	cal/cm ² ·s	W/cm ²	cal/cm ² ·s	W/cm ²	ΔT, ° F	ΔT, °C	
(1)	(2)	(3)	(4)	(5)	(6)	(7)	(8)
1	1.2	5.0	1.20	5.0	16.0	8.9	0.46
2	0.73	3.1	1.46	6.1	19.5	10.8	0.57
3	0.55	2.3	1.65	6.9	22.0	12.2	0.63
4	0.45	1.9	1.80	7.5	24.0	13.3	0.69
5	0.38	1.6	1.90	8.0	25.3	14.1	0.72
6	0.34	1.4	2.04	8.5	27.2	15.1	0.78
7	0.30	1.3	2.10	8.8	28.0	15.5	0.80
8	0.274	1.15	2.19	9.2	29.2	16.2	0.83
9	0.252	1.06	2.27	9.5	30.2	16.8	0.86
10	0.233	0.98	2.33	9.8	31.1	17.3	0.89
11	0.219	0.92	2.41	10.1	32.1	17.8	0.92
12	0.205	0.86	2.46	10.3	32.8	18.2	0.94
13	0.194	0.81	2.52	10.6	33.6	18.7	0.97
14	0.184	0.77	2.58	10.8	34.3	19.1	0.99
15	0.177	0.74	2.66	11.1	35.4	19.7	1.02
16	0.168	0.70	2.69	11.3	35.8	19.8	1.03
17	0.160	0.67	2.72	11.4	36.3	20.2	1.04
18	0.154	0.64	2.77	11.6	37.0	20.6	1.06
19	0.148	0.62	2.81	11.8	37.5	20.8	1.08
20	0.143	0.60	2.86	12.0	38.1	21.1	1.10
25	0.122	0.51	3.05	12.8	40.7	22.6	1.17
30	0.107	0.45	3.21	13.4	42.8	23.8	1.23

^A Stoll, A. M. and Chianta, M. A., "Method and Rating System for Evaluations of Thermal Protection," *Aerospace Medicine*, Vol 40, 1969, pp. 1232–1238 and Stoll, A. M. and Chianta, M. A., Heat Transfer through Fabrics as Related to Thermal Injury, "Transaction-New York Academy of Sciences," Vol 33 (7), Nov. 1971, pp 649–670.
^B A calorimeter with an iron/constantan thermocouple.

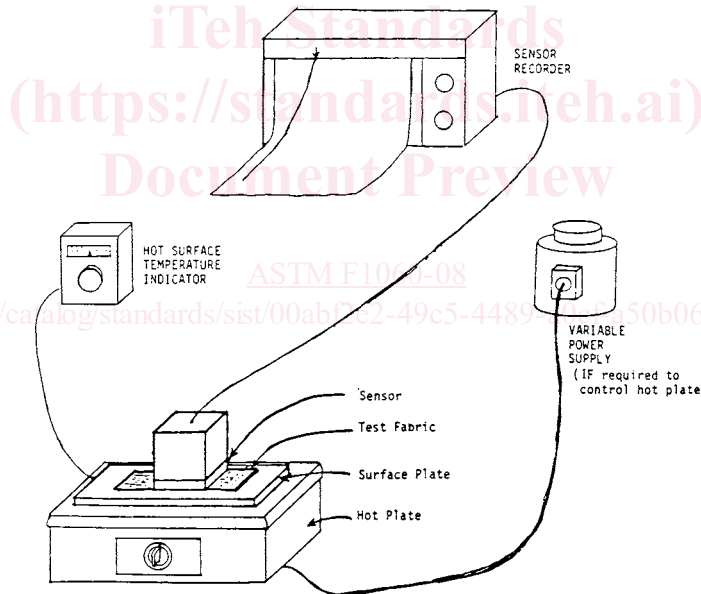
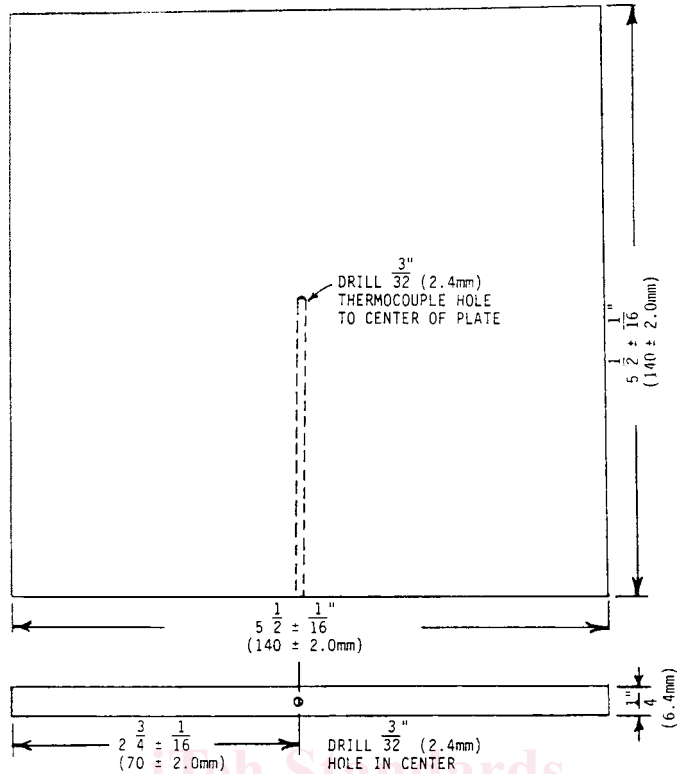

FIG. 1 Thermal Protective Performance Apparatus, Hot Surface Contact

$$q = \frac{mass \times C_p \times (Temp_{final} - Temp_{initial})}{area \times (time_{final} - time_{initial})} \tag{1}$$



Material: Electrolytic Copper or T-1100 aluminum

FIG. 2 Surface Plate

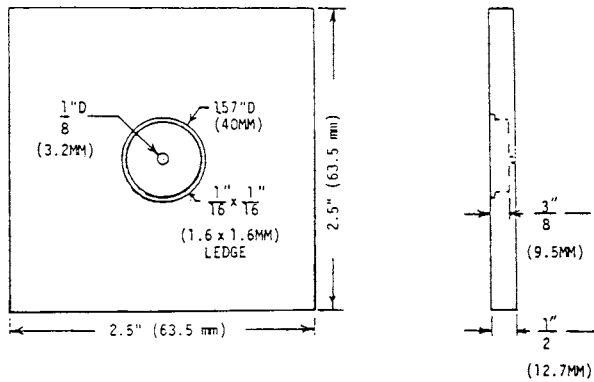
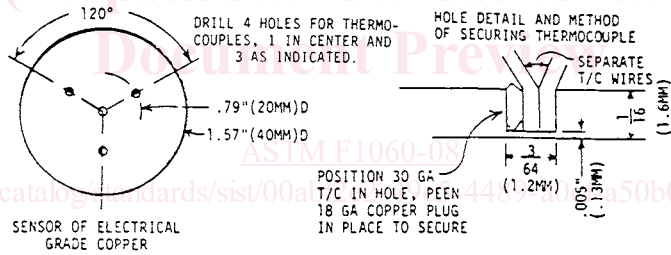

SENSOR SUPPORT OF SOFT INSULATION BOARD

CONNECT 4 T/C IN PARALLEL, SILVER SOLDER CONNECTIONS. BRING COMMON LEAD OUT OF CENTER HOLE OF SUPPORT. SENSOR TO BE SNUG FIT AND FLUSH TO SURFACE IN INSULATION BOARD. SPRAY PAINT SENSOR FLAT BLACK.

FIG. 3 Details of Calorimeter Construction