

Draft **ETSI EN 301 390** V2.0.0 (2021-08)



**Fixed Radio Systems;
Point-to-point and Multipoint Systems;
Unwanted emissions in the spurious domain and
receiver immunity limits at
equipment/antenna port of Digital Fixed Radio Systems**

ETSI EN 301 390 V2.0.0 (2021-08)
https://www.etsi.org/standards-store
078282f84d9e/etsi-en-301-390-v2-0-0-2021-08

Reference

REN/ATTM-0452

Keywords

emission, FWS, immunity, multipoint, point-to-point

ETSI

650 Route des Lucioles
F-06921 Sophia Antipolis Cedex - FRANCE

Tel.: +33 4 92 94 42 00 Fax: +33 4 93 65 47 16

Siret N° 348 623 562 00017 - APE 7112B
Association à but non lucratif enregistrée à la
Sous-Préfecture de Grasse (06) N° w061004871

Important notice

The present document can be downloaded from:

<http://www.etsi.org/standards-search>

The present document may be made available in electronic versions and/or in print. The content of any electronic and/or print versions of the present document shall not be modified without the prior written authorization of ETSI. In case of any existing or perceived difference in contents between such versions and/or in print, the prevailing version of an ETSI deliverable is the one made publicly available in PDF format at www.etsi.org/deliver.

Users of the present document should be aware that the document may be subject to revision or change of status.

Information on the current status of this and other ETSI documents is available at

<https://portal.etsi.org/TB/ETSIDeliverableStatus.aspx>

If you find errors in the present document, please send your comment to one of the following services:

<https://portal.etsi.org/People/CommitteeSupportStaff.aspx>

Notice of disclaimer & limitation of liability

The information provided in the present deliverable is directed solely to professionals who have the appropriate degree of experience to understand and interpret its content in accordance with generally accepted engineering or other professional standard and applicable regulations.

No recommendation as to products and services or vendors is made or should be implied.

In no event shall ETSI be held liable for loss of profits or any other incidental or consequential damages.

Any software contained in this deliverable is provided "AS IS" with no warranties, express or implied, including but not limited to, the warranties of merchantability, fitness for a particular purpose and non-infringement of intellectual property rights and ETSI shall not be held liable in any event for any damages whatsoever (including, without limitation, damages for loss of profits, business interruption, loss of information, or any other pecuniary loss) arising out of or related to the use of or inability to use the software.

Copyright Notification

No part may be reproduced or utilized in any form or by any means, electronic or mechanical, including photocopying and microfilm except as authorized by written permission of ETSI.

The content of the PDF version shall not be modified without the written authorization of ETSI.

The copyright and the foregoing restriction extend to reproduction in all media.

© ETSI 2021.
All rights reserved.

Contents

| | |
|--|-----------|
| Intellectual Property Rights | 4 |
| Foreword..... | 4 |
| Modal verbs terminology..... | 5 |
| Introduction | 6 |
| 1 Scope | 7 |
| 2 References | 7 |
| 2.1 Normative references | 7 |
| 2.2 Informative references..... | 8 |
| 3 Definition of terms, symbols and abbreviations..... | 9 |
| 3.1 Terms..... | 9 |
| 3.2 Symbols..... | 10 |
| 3.3 Abbreviations | 10 |
| 4 Transmitter unwanted emissions in the spurious domain at antenna port..... | 12 |
| 4.1 Background | 12 |
| 4.2 Limits | 12 |
| 4.2.0 Generality | 12 |
| 4.2.1 Point-to-point equipment | 12 |
| 4.2.2 Multipoint equipment | 13 |
| 4.2.3 Broadband Wireless Access equipment operating between 1 GHz and 6 GHz..... | 13 |
| 5 Receiver spurious emissions at the antenna port..... | 13 |
| 6 Spurious domain emissions test method..... | 13 |
| 7 Receiver immunity at antenna port..... | 13 |
| 7.0 Definitions..... | 13 |
| 7.1 Limits | 14 |
| 7.2 Receiver immunity test method..... | 15 |
| Annex A (informative): Application of CEPT/ERC Recommendation 74-01..... | 16 |
| A.0 Introduction | 16 |
| A.1 Frequency range of applicability..... | 16 |
| A.2 Level limits..... | 18 |
| A.3 Reference bandwidths | 19 |
| A.4 Detailed application of the reference bandwidths reported in table A.3 | 24 |
| A.4.0 Foreword | 24 |
| A.4.1 P-P and P-MP systems with fundamental emissions from 30 MHz to 1 GHz..... | 24 |
| A.4.2 P-P and P-MP systems with fundamental emissions from 1 GHz to 21,2 GHz | 24 |
| A.4.3 P-P and P-MP systems with fundamental emissions above 21,2 GHz | 25 |
| Annex B (informative): Measurement background | 26 |
| B.1 Spectrum analyser capability..... | 26 |
| B.2 Application examples..... | 27 |
| History | 33 |

Intellectual Property Rights

Essential patents

IPRs essential or potentially essential to normative deliverables may have been declared to ETSI. The declarations pertaining to these essential IPRs, if any, are publicly available for **ETSI members and non-members**, and can be found in ETSI SR 000 314: "*Intellectual Property Rights (IPRs); Essential, or potentially Essential, IPRs notified to ETSI in respect of ETSI standards*", which is available from the ETSI Secretariat. Latest updates are available on the ETSI Web server (<https://ipr.etsi.org/>).

Pursuant to the ETSI Directives including the ETSI IPR Policy, no investigation regarding the essentiality of IPRs, including IPR searches, has been carried out by ETSI. No guarantee can be given as to the existence of other IPRs not referenced in ETSI SR 000 314 (or the updates on the ETSI Web server) which are, or may be, or may become, essential to the present document.

Trademarks

The present document may include trademarks and/or tradenames which are asserted and/or registered by their owners. ETSI claims no ownership of these except for any which are indicated as being the property of ETSI, and conveys no right to use or reproduce any trademark and/or tradename. Mention of those trademarks in the present document does not constitute an endorsement by ETSI of products, services or organizations associated with those trademarks.

DECT™, **PLUGTESTS™**, **UMTS™** and the ETSI logo are trademarks of ETSI registered for the benefit of its Members. **3GPP™** and **LTE™** are trademarks of ETSI registered for the benefit of its Members and of the 3GPP Organizational Partners. **oneM2M™** logo is a trademark of ETSI registered for the benefit of its Members and of the oneM2M Partners. **GSM®** and the GSM logo are trademarks registered and owned by the GSM Association.

ITEH STANDARD PREVIEW
(standards.iteh.ai)

Foreword

ETSI EN 301 390 V2.0.0 (2021-08)

This draft European Standard (EN) has been produced by ETSI Technical Committee Access, Terminals, Transmission and Multiplexing (ATTM), and is now submitted for the combined Public Enquiry and Vote phase of the ETSI standards EN Approval Procedure.

| Proposed national transposition dates | |
|--|---------------------------------|
| Date of latest announcement of this EN (doa): | 3 months after ETSI publication |
| Date of latest publication of new National Standard or endorsement of this EN (dop/e): | 6 months after doa |
| Date of withdrawal of any conflicting National Standard (dow): | 6 months after doa |

Major changes with respect to previous version

This revision is consequent to 2019 revision of CEPT/ERC Recommendation 74-01 [1], which revised the resolution bandwidth staircase for the limits of *unwanted emissions in the spurious domain* also for system with *channel separation* higher than 28 MHz and added specific limits for "*channels-aggregation*" systems as defined in ETSI EN 302 217-2 [i.7]. In addition, standing the poor penetration of multipoint systems in the so-called HDFS (High Density Fixed Service) bands (see 5.547 in the Radio Regulations [i.12]), limits for multipoint equipment with fundamental emission above 21,2 GHz have also been aligned to those required by CEPT/ERC Recommendation 74-01 [1].

Examples in clause B.2 have been updated as appropriate.

Modal verbs terminology

In the present document "**shall**", "**shall not**", "**should**", "**should not**", "**may**", "**need not**", "**will**", "**will not**", "**can**" and "**cannot**" are to be interpreted as described in clause 3.2 of the [ETSI Drafting Rules](#) (Verbal forms for the expression of provisions).

"**must**" and "**must not**" are **NOT** allowed in ETSI deliverables except when used in direct citation.

iTeh STANDARD PREVIEW
(standards.iteh.ai)

[ETSI EN 301 390 V2.0.0 \(2021-08\)](#)

<https://standards.iteh.ai/catalog/standards/sist/f1873812-7087-457a-b1bb-078282f84d9e/etsi-en-301-390-v2-0-0-2021-08>

Introduction

The term Spurious emissions is used for simplicity elsewhere in the present document but with the more broader meaning of "*unwanted emissions in the spurious domain*" introduced by Recommendation ITU-R SM.329-12 [i.13] for clarifying the Radio Regulation definitions and the application of recommended limits for all *unwanted emissions*; it also recommends that spurious emissions limits apply to all unwanted emissions falling in the spurious domain.

Therefore the present document deals with limits for *unwanted emissions in the spurious domain* at antenna port of Digital Fixed Radio Systems (DFRS) as defined by Recommendation ITU-R SM.329-12 [i.13] and CEPT/ERC Recommendation 74-01 [1] and ECC Recommendation (02)05 [i.18].

Moreover it covers characteristics of immunity from interference at receiver's antenna port.

Unwanted emissions in the spurious domain and immunity performance at antenna port are also relevant to essential requirements under article 3.2 of Directive 2014/53/EU [i.11] on Radio Equipment (RED).

Additional considerations and background for producing the present document are:

- Recommendation ITU-R SM.329-12 [i.13] considers emissions from any system, including digital modulation and allows options for the definition of the frequency boundary between *out-of-band domain* and *spurious domain*. It recommends different category of level limits applicable to the Fixed Service;
- Recommendation ITU-R SM.1539-1 [i.14] describes the application of the boundary concept between out-of-band and spurious domains;
- Recommendation ITU-R F.1191-3 [i.15] define the application of Radio Regulations [i.12] and the concepts of out-of-band, unwanted and spurious emissions to DFRS, clarify the applicability for the boundary between out-of-band and Spurious emissions domains but maintain the same possible limit options provided by Recommendation ITU-R SM.329-12 [i.13];
- CEPT/ERC Recommendation 74-01 [1], endorses only the more stringent Category B limits of Recommendation ITU-R SM.329-12 [i.13];
- for the purpose of Directive 2014/53/EU [i.11] the emissions and immunity at antenna port fall under its article 3.2 requirements for "effective use of spectrum" and "avoidance of harmful interference";
- it is convenient to maintain a single ETSI EN covering these parameters instead of replicating them on each single product standard, avoiding possible deviation from what required by other CEPT and ITU-R normative;
- limits for *unwanted emissions in the spurious domain* are supposed to be fixed in view of inter-working compatibility among various Fixed Radio Systems in same or different band exploited in the same area;
- the measurement of the required limits should also be feasible in a suitable and cost effective conformance test (annex B gives also information in this field);
- it is necessary that DFRS receivers provide a minimum level of immunity at antenna port towards possible interference at any frequency band of practical interest;
- a suitable and easy to perform criterion for DFRS receivers immunity at antenna port may be considered the application of a CW interference.

1 Scope

The scope of the present document is to define specific limits at antenna port for *unwanted emissions in the spurious domain* and receiver immunity for suitable inter-working of Digital Fixed Radio Systems (i.e. Point-to-point and Multipoint systems) in the same or in different frequency band whenever allocated to Fixed Service in the range 9 kHz to 300 GHz.

However systems with fundamental emission below 30 MHz are not considered relevant for Digital Fixed Radio Systems and are outside the scope of the present document.

The present document adopts CEPT/ERC Recommendation 74-01 [1] which gives limits for Unwanted emissions in the Spurious domain with particular regards to "inter Services" operations.

In addition, it is recognized the need for a general requirement for receiver immunity to relatively high interference signals generated by any source and at any frequency in the same range identified as *spurious domain* by CEPT/ERC Recommendation 74-01 [1].

Some ETSI deliverables for DFRS provide limits for both "external" and "internal" spurious domain emissions and the latter are outside the scope of the present document. Moreover the limits for emissions given in the present document do not prevent more stringent requirement given in those deliverables for intra-system purpose (i.e. local Transmitter to Receiver interference usually referred as "internal").

In order to help the understanding of limits given in CEPT/ERC Recommendation 74-01 [1], in annex B, *unwanted emissions in the spurious domain* are analysed from the point of view of a suitable test method for conformance testing.

2 References

2.1 Normative references

References are either specific (identified by date of publication and/or edition number or version number) or non-specific. For a specific reference, only the cited version applies. For a non-specific reference, the latest version of the referenced document (including any amendments) applies.

Referenced documents which are not found to be publicly available in the expected location might be found at <http://docbox.etsi.org/Reference>.

NOTE: While any hyperlinks included in this clause were valid at the time of publication, ETSI cannot guarantee their long term validity.

The following referenced documents are necessary for the application of the present document.

- [1] CEPT/ERC Recommendation 74-01 (2019): "Unwanted emissions in the spurious domain".
- [2] Void.
- [3] ETSI EN 301 126-1: "Fixed Radio Systems; Conformance testing; Part 1: Point-to-Point equipment - Definitions, general requirements and test procedures".
- [4] ETSI EN 301 126-2-1: "Fixed Radio Systems; Conformance testing; Part 2-1: Point-to-Multipoint equipment; Definitions and general requirements".
- [5] ETSI EN 301 126-2-2: "Fixed Radio Systems; Conformance testing; Part 2-2: Point-to-Multipoint equipment; Test procedures for FDMA systems".
- [6] ETSI EN 301 126-2-3: "Fixed Radio Systems; Conformance testing; Part 2-3: Point-to-Multipoint equipment; Test procedures for TDMA systems".
- [7] ETSI EN 301 126-2-4: "Fixed Radio Systems; Conformance testing; Part 2-4: Point-to-Multipoint equipment; Test procedures for FH-CDMA systems".

- [8] ETSI EN 301 126-2-5: "Fixed Radio Systems; Conformance testing; Part 2-5: Point-to-Multipoint equipment; Test procedures for DS-CDMA systems".
- [9] ETSI EN 301 126-2-6: "Fixed Radio Systems; Conformance testing; Part 2-6: Point-to-Multipoint equipment; Test procedures for Multi Carrier Time Division Multiple Access (MC-TDMA) systems".

2.2 Informative references

References are either specific (identified by date of publication and/or edition number or version number) or non-specific. For a specific reference, only the cited version applies. For a non-specific reference, the latest version of the referenced document (including any amendments) applies.

NOTE: While any hyperlinks included in this clause were valid at the time of publication, ETSI cannot guarantee their long term validity.

The following referenced documents are not necessary for the application of the present document but they assist the user with regard to a particular subject area.

- [i.1] Void.
- [i.2] Void.
- [i.3] Void.
- [i.4] Void.
- [i.5] Void. iTeh STANDARD PREVIEW
(standards.iteh.ai)
- [i.6] Void.
- [i.7] ETSI EN 302 217-2: "Fixed Radio Systems; Characteristics and requirements for point-to-point equipment and antennas; Part 2: Digital systems operating in frequency bands from 1 GHz to 86 GHz; Harmonised Standard for access to radio spectrum".
<https://standards.iteh.ai/catalog/standards/sist/1709512-700-078282f84d9e/etsi-en-301-390-v2-0-0-2021-08>
- [i.8] ETSI EN 302 217-1: "Fixed Radio Systems; Characteristics and requirements for point-to-point equipment and antennas; Part 1: Overview, common characteristics and requirements not related to access to radio spectrum".
- [i.9] ETSI TR 101 036-1: "Fixed Radio Systems; Generic wordings for standards on DFRS (Digital Fixed Radio Systems) characteristics; Part 1: General aspects and point-to-point equipment parameters".
- [i.10] Recommendation ITU-R F.746-10: "Radio-frequency arrangements for fixed service systems".
- [i.11] Directive 2014/53/EU of the European Parliament and of the Council of 16 April 2014 on the harmonisation of the laws of the Member States relating to the making available on the market of radio equipment and repealing Directive 1999/5/EC.
- [i.12] ITU-R Radio Regulations (2020).
- [i.13] Recommendation ITU-R SM.329-12: "Unwanted emissions in the spurious domain".
- [i.14] Recommendation ITU-R SM.1539-1: "Variation of the boundary between the out-of-band and spurious domains required for the application of Recommendations ITU-R SM.1541 and ITU-R SM.329".
- [i.15] Recommendation ITU-R F.1191-3: "Necessary and occupied bandwidths and unwanted emissions of digital fixed service systems".
- [i.16] ECC Report 100: "Compatibility Studies in the Band 3400- 3800 MHz between Broadband Wireless Access (BWA) Systems and other Services".

[i.17] EC REF:Ares(2019)5616840 - Further response to the EC on ERC/REC 74-01 for ETSI X-band radar standards.

NOTE: Available as [ECC\(20\)093 Annex 14](#) (CEPT website password required).

[i.18] ECC Recommendation (02)05 (2012): "Unwanted emissions".

3 Definition of terms, symbols and abbreviations

3.1 Terms

For the purposes of the present document, the following terms apply:

boundary between out-of-band and spurious domains: frequency limit that subdivides the two domains and the applicability of relevant requirements

NOTE: Recommendations ITU-R SM.329-12 [i.13] and SM.1539-1 [i.14] describe the possible application to all radio emissions. Recommendation ITU-R F.1191-3 [i.15] details it for Fixed Service systems.

Broadband Wireless Access (BWA) system: access system used for the deployment of radio access networks in both the fixed service and the mobile service

NOTE: BWA applications were introduced by ECC Report 100 [i.16] as:
"BWA systems were considered in the report, covering various BWA usage modes, i.e. Fixed (FWA), Nomadic (NWA) and Mobile (MWA) Wireless Access"
 Therefore, the technology of BWA may indifferently refer to the fixed or the mobile service regulation.

Channel Separation (CS): distance between adjacent channels in a radio frequency channels arrangement (defined in ECC or ITU-R or national recommendations)

NOTE 1: It represents one of the major parameters for the identification of the radio equipment use and relevant requirements.

NOTE 2: Some channel arrangements give only a continuous raster of elementary frequency slots for composing multiple ($N \times$ elementary slot) aggregated channels of various size. In this case the actual CS would be equal to the $N \times$ elementary slot used by the radio system. When no channel arrangement or elementary slot raster is defined in the band of operation of the radio system, the *occupied bandwidth* should be considered in substitution of the CS.

Continuous wave (CW) signal: signal with spectral emission on a single frequency only

NOTE: Unavoidable phase-noise spectral components of the CW source are not to be taken into account.

EN: European Standard (Telecommunications series)

evaluation bandwidth: bandwidth where the spurious domain emission limits are measured (e.g. the spectrum analyser resolution bandwidth) for further normalization/integration to the reference bandwidth

Gross Symbol Frequency G_{SF} : the maximum frequency of variance of the different states of the modulator (e.g. 256 states for 256 QAM modulation formats); it is equal to the maximum (gross) bit rate (i.e. inclusive of any payloads, control and service data, overhead and error correction codes to be transmitted) divided by the modulation index "n" (e.g. $n = 8$ for $2^n = 256$ in 256 QAM)

necessary bandwidth (1.152 of Radio Regulations [i.12]):

"For a given class of emission, the width of the frequency band which is just sufficient to ensure the transmission of information at the rate and with the quality required under specified conditions"

NOTE: Recommendation ITU-R F.1191-3 [i.15] establishes that for DFRS the *necessary bandwidth* is considered coincident with the *occupied bandwidth*.

noise-like emissions: emissions characterized by a distributed power density within the *reference* and *evaluation bandwidths*

occupied bandwidth (1.153 of Radio Regulations [i.12]):

"width of a frequency band such that, below the lower and above the upper frequency limits, the mean powers emitted are each equal to a specified percentage $\beta/2$ of the total mean power of a given emission (Radio Regulations [i.12])"

NOTE: For the purpose of the present document, $\beta/2$ is assumed to be equal to 0,5 % (Recommendation ITU-R F.1191-3 [i.15]).

out-of-band domain (of an emission) (1.146A of Radio Regulations [i.12]):

"frequency range, immediately outside the *necessary bandwidth* but excluding the *spurious domain*, in which *out-of-band emissions* generally predominate.

Out-of-band emissions, defined based on their source, occur in the out-of-band domain and, to a lesser extent, in the spurious domain. Spurious emissions likewise may occur in the out-of-band domain as well as in the spurious domain. However, the limit in the out-of-band-domain applies to any *unwanted emissions* independently from their formal identification as out-of-band or spurious emissions"

receiver spurious emissions: spurious sent backwards to the antenna port by a receiver

NOTE: Sometimes they are also referenced as "spurious radiations".

reference bandwidth: bandwidth where the spurious emission limits are defined

NOTE: See also Recommendation ITU-R SM.329-12 [i.13].

spurious domain (of an emission) (1.146B of Radio Regulations [i.12]):

"frequency range beyond the *out-of-band domain* in which *spurious emissions* generally predominate.

Spurious emissions may occur in the *out-of-band domain* as well as in the *spurious domain*. Likewise *out-of-band emissions*, defined based on their source, occur in the *out-of-band domain* and, to a lesser extent, in the *spurious domain*. However, the limit in the *spurious-domain* applies to any *unwanted emissions* independently from their formal identification as *out-of-band* or *spurious emissions*

unwanted emissions (1.146 of Radio Regulations [i.12]):

"emissions composed by *out-of-band* and *spurious emissions*"

unwanted emissions in the out-of-band domain: any unwanted emission, outside the channel bandwidth, which falls at frequencies separated from the centre frequency of the emission by less than 250 % (see note) of the relevant *Channel Separation (CS)*, where the system is intended to be used

NOTE: When $CS > 500$ MHz the 250 % should be substituted by $(150 \% CS + 500 \text{ MHz})$, see CEPT/ERC Recommendation 74-01 [1].

unwanted emissions in the spurious domain : any unwanted emission which falls at frequencies separated from the centre frequency of the emission by 250 % (see note) or more of the relevant *channel separation*, where the system is intended to be used

NOTE: When $CS > 500$ MHz the 250 % should be substituted by $(150 \% CS + 500 \text{ MHz})$, see CEPT/ERC Recommendation 74-01 [1].

3.2 Symbols

For the purposes of the present document, the following symbols apply:

| | |
|-----------------|---|
| dBc | decibels relative to carrier mean power |
| dB _i | decibel relative to an isotropic radiator |
| dBm | decibels relative to milliwatt |
| GHz | GigaHertz |
| kHz | kiloHertz |
| MHz | MegaHertz |

3.3 Abbreviations

For the purposes of the present document, the following abbreviations apply:

| | |
|-----|---------------------|
| ATe | external ATtenuator |
|-----|---------------------|

| | |
|------|---|
| ATi | internal spectrum analyser input ATtenuator |
| ATPC | Automatic Transmission Power Control |
| BER | Bit Error Rate |
| BS | Base (Master) Station of a P-MP system |
| BW | BandWidth |
| BWA | Broadband Wireless Access |
| BWe | evaluation BandWidth for spectral measurement |

NOTE: I.e. spectrum analyser resolution bandwidth.

| | |
|-----------------|---|
| BW _r | reference BandWidth |
| CEPT | Conférence Européenne des administrations des Postes et des Télécommunications (European Conference of Postal and Telecommunications administrations) |
| CS | Channel Separation |
| CW | Continuous Wave |
| DFRS | Digital Fixed Radio Systems |
| DUT | Device Under Test |
| EC | European Commission |
| ECC | Electronic Communication Committee of the CEPT |
| EN | Europäische Normung |
| ERC | European Radiocommunications Committee of the CEPT, presently become ECC |
| F _c | cut-off Frequency |
| FS | Fixed Service |
| G _{SF} | Gross Symbol Frequency |
| HDFS | High Density Fixed Service |
| i.m.p. | intermodulation products |
| IM | InterModulation |
| ITU-R | International Telecommunication Union - Radiocommunications standardization sector |
| MP | MultiPoint |

NOTE: Generic term including both P-MP and MP to MP mesh architectures.

| | |
|-------|--------------------------------------|
| NB | Necessary Bandwidth |
| OJEU | Official Journal of European Union |
| P-MP | Point-to-MultiPoint system |
| P-P | Point-to-Point system |
| QAM | Quadrature Amplitude Modulation |
| RF | Radio Frequency |
| RS | Repeater Station (of a P-MP system) |
| RSL | Receiver Signal Level |
| Rx | Receiver |
| SM | Spectrum Management |
| STM-0 | Synchronous Transport Module Level 0 |
| STM-1 | Synchronous Transport Module Level 1 |
| TS | Terminal Station |

NOTE: Remote out-station with subscriber interface of a P-MP system.

| | |
|------|-----------------------------|
| Tx | Transmitter |
| VSWR | Voltage Standing Wave Ratio |
| WRC | World Radio Conference |

4 Transmitter unwanted emissions in the spurious domain at antenna port

4.1 Background

For the purpose of the present document the terms defined in clause 3.1 are printed in "*italic*".

The *spurious domain* (of an emission) is defined in the Radio Regulations [i.12] 1.146B (see clause 3.1).

For Fixed Service (FS), CEPT/ERC Recommendation 74-01 [1] is based on Recommendation ITU-R SM.329-12 [i.13] and its applicability to FS provided by Recommendation ITU-R F.1191-3 [i.15].

CEPT/ERC Recommendation 74-01 [1], prescribes that the *spurious domain* emissions limits are applied to any *unwanted emissions* at frequencies which are:

- For *channel separations* (CS) ≤ 500 MHz:
at frequencies which are outside the [nominal] carrier frequency by more than ± 250 % of the relevant CS.
- For *channel separation* (CS) > 500 MHz:
as given in Recommendation ITU-R SM.1539-1 [i.14] at frequencies which are outside the [nominal] carrier frequency by more than $\pm (500 \text{ MHz} + 150 \% \text{ CS [MHz]})$.

According Recommendation ITU-R F.1191-3 [i.15], the *Channel separation* (CS) is taken as $XS/2$ for alternated frequency channel arrangements and XS for co-channel and interleaved frequency channel arrangements as defined by Recommendation ITU-R F.746-10 [i.10].

The emission within ± 250 %, or in case $\pm (500 \text{ MHz} + 150 \%)$, of the relevant *channel separation* includes only fundamental and *unwanted emissions in the out-of-band domain* (which are outside the scope of the present document). The out of band domain is defined in Radio Regulations [i.12] 1.146A (see clause 3.1).

STANDARD PREVIEW
(standards.iteh.ai)

ETSI EN 301 390 V2.0.0 (2021-08)

<https://standards.iteh.ai/catalog/standards/sist/f1873812-7087-457a-b1bb-078282f84d9e/etsi-en-301-390-v2-0-0-2021-08>

4.2 Limits

4.2.0 Generality

The *unwanted emissions in the spurious domain* of the transmitter and the *receiver spurious emissions*, delivered to the antenna port of Fixed Radio Systems, shall be limited within the average power limits reported below.

For "*noise-like*" *unwanted emissions*, the limits are intended not to be exceeded in any elementary *evaluation bandwidth*.

The limit values are defined at reference point C' shown in the general RF block diagram of figure 1.

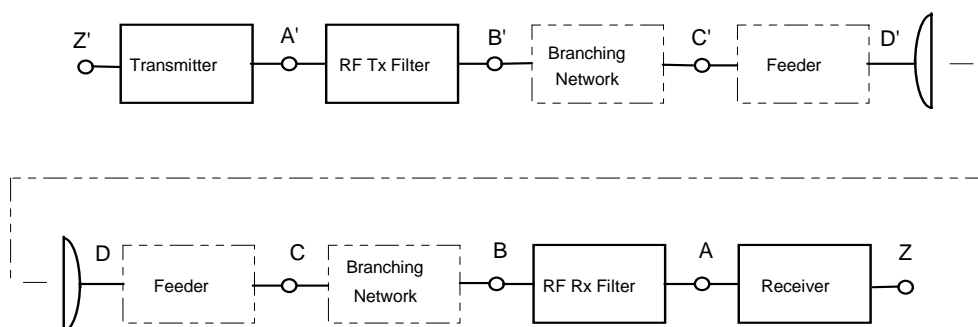

Figure 1: RF block diagram

4.2.1 Point-to-point equipment

The CEPT/ERC Recommendation 74-01 [1] and its FS specific annex 1 shall apply.