

INTERNATIONAL
STANDARD

ISO
1081

NORME
INTERNATIONALE

Third edition
Troisième édition
2013-12-01

**Belt drives — V-belts and V-ribbed
belts, and corresponding grooved
pulleys — Vocabulary**

**Transmissions par courroies —
Courroies trapézoïdales et striées, et
poulies à gorges — Vocabulaire**

iteh Standards
(<https://standards.iteh.ai>)
Document Preview

[ISO 1081:2013](https://standards.iteh.ai/catalog/standards/iso/047a281f-3b09-4547-9d48-df17c1c18ee0/iso-1081-2013)

<https://standards.iteh.ai/catalog/standards/iso/047a281f-3b09-4547-9d48-df17c1c18ee0/iso-1081-2013>



Reference number
Numéro de référence
ISO 1081:2013(E/F)

© ISO 2013

iTeh Standards
(<https://standards.iteh.ai>)
Document Preview

ISO 1081:2013



COPYRIGHT PROTECTED DOCUMENT
DOCUMENT PROTÉGÉ PAR COPYRIGHT

© ISO 2013

The reproduction of the terms and definitions contained in this International Standard is permitted in teaching manuals, instruction booklets, technical publications and journals for strictly educational or implementation purposes. The conditions for such reproduction are: that no modifications are made to the terms and definitions; that such reproduction is not permitted for dictionaries or similar publications offered for sale; and that this International Standard is referenced as the source document.

With the sole exceptions noted above, no other part of this publication may be reproduced or utilized otherwise in any form or by any means, electronic or mechanical, including photocopying, or posting on the internet or an intranet, without prior written permission. Permission can be requested from either ISO at the address below or ISO's member body in the country of the requester.

La reproduction des termes et des définitions contenus dans la présente Norme internationale est autorisée dans les manuels d'enseignement, les modes d'emploi, les publications et revues techniques destinés exclusivement à l'enseignement ou à la mise en application. Les conditions d'une telle reproduction sont les suivantes: aucune modification n'est apportée aux termes et définitions; la reproduction n'est pas autorisée dans des dictionnaires ou publications similaires destinés à la vente; la présente Norme internationale est citée comme document source.

À la seule exception mentionnée ci-dessus, aucune partie de cette publication ne peut être reproduite ni utilisée sous quelque forme que ce soit et par aucun procédé, électronique ou mécanique, y compris la photocopie, l'affichage sur l'internet ou sur un Intranet, sans autorisation écrite préalable. Les demandes d'autorisation peuvent être adressées à l'ISO à l'adresse ci-après ou au comité membre de l'ISO dans le pays du demandeur.

ISO copyright office
Case postale 56 • CH-1211 Geneva 20
Tel. + 41 22 749 01 11
Fax + 41 22 749 09 47
E-mail copyright@iso.org
Web www.iso.org

Published in Switzerland/Publié en Suisse

Contents

	Page
Foreword	iv
0 Scope	1
1 Terms and definitions relating to V-belts and grooved pulleys	1
1.1 General terms and definitions.....	1
1.2 Terms and definitions relating to the system based on data widths.....	5
1.3 Terms and definitions relating to the system based on effective width.....	7
2 Terms and definitions related to V-belts and ribbed pulleys	9
2.1 General terms and definitions.....	9
3 Terms and definitions relating to tension	14
4 Terms and definitions relating to modulus	14

iTeh Standards
(<https://standards.itih.ai>)
Document Preview

[ISO 1081:2013](https://standards.itih.ai/catalog/standards/iso/047a281f-3b09-4547-9d48-df17c1c18ee0/iso-1081-2013)

<https://standards.itih.ai/catalog/standards/iso/047a281f-3b09-4547-9d48-df17c1c18ee0/iso-1081-2013>

Foreword

ISO (the International Organization for Standardization) is a worldwide federation of national standards bodies (ISO member bodies). The work of preparing International Standards is normally carried out through ISO technical committees. Each member body interested in a subject for which a technical committee has been established has the right to be represented on that committee. International organizations, governmental and non-governmental, in liaison with ISO, also take part in the work. ISO collaborates closely with the International Electrotechnical Commission (IEC) on all matters of electrotechnical standardization.

The procedures used to develop this document and those intended for its further maintenance are described in the ISO/IEC Directives, Part 1. In particular the different approval criteria needed for the different types of ISO documents should be noted. This document was drafted in accordance with the editorial rules of the ISO/IEC Directives, Part 2. www.iso.org/directives

Attention is drawn to the possibility that some of the elements of this document may be the subject of patent rights. ISO shall not be held responsible for identifying any or all such patent rights. Details of any patent rights identified during the development of the document will be in the Introduction and/or on the ISO list of patent declarations received. www.iso.org/patents

Any trade name used in this document is information given for the convenience of users and does not constitute an endorsement.

For an explanation on the meaning of ISO specific terms and expressions related to conformity assessment, as well as information about ISO's adherence to the WTO principles in the Technical Barriers to Trade (TBT) see the following URL: Foreword - Supplementary information

The committee responsible for this document is ISO/TC 41, *Pulleys and belts (including veebelts)*, SC 1, *Veebelts and grooved pulleys*.

This third edition cancels and replaces the second edition (ISO 1081:1995), which has been technically revised.

[ISO 1081:2013](https://standards.iteh.ai/catalog/standards/iso/047a281f-3b09-4547-9d48-df17c1c18ee0/iso-1081-2013)

<https://standards.iteh.ai/catalog/standards/iso/047a281f-3b09-4547-9d48-df17c1c18ee0/iso-1081-2013>

Belt drives — V-belts and V-ribbed belts, and corresponding grooved pulleys — Vocabulary

0 Scope

This International Standard specifies the terms and definitions, in English and French, relating to aromatic natural raw materials.

This International Standard defines terms relating to V-belt drives, V-belts, hexagonal belts, joined V-belts and the corresponding V-grooved pulleys, V-ribbed belt drives, V-ribbed belts and V-ribbed pulleys, as well as the corresponding symbols.

The general definitions are valid irrespective of the system describing the pulleys.

The dimensions of pulley grooves can be defined either on the basis of the datum width or on the basis of the effective width. As a result, two systems for the definition and description of the dimensions of pulleys and belts have been developed. The two systems are independent of each other.

1 Terms and definitions relating to V-belts and grooved pulleys

1.1 General terms and definitions

1.1.1 Belts

1.1.1.1

V-belt

belt, the cross-section of which is shaped roughly like a regular trapezium

Note 1 to entry: On a cross-section of a straight-sided belt, the trapezium is outlined by the base, sides and top of the belt.

Note 2 to entry: The intersection of the extended profiles of the base, side and top is considered when edges are cut short or rounded.

Note 3 to entry: See [Figure 1](#).

1.1.1.1.1

hexagonal belt

special belt with hexagonal cross-section consisting of two equal isosceles trapezia joined at their wider base

1.1.1.1.2

joined V-belt

two or more equal trapezoidal V-belts placed side by side in a definite distance and joined by a covering band

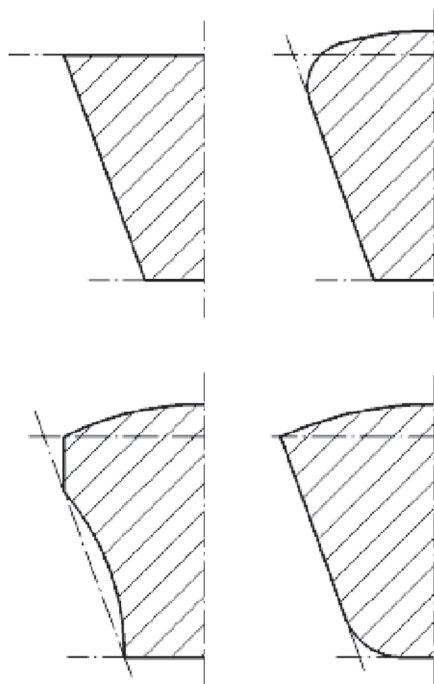

Figure 1 — V-belts

**1.1.1.2
pitch line**

any circumferential line in the belt which keeps the same length when the belt is bent perpendicularly to its base

Note 1 to entry: See [Figure 2](#).



Key

1 pitch line

Figure 2 — Pitch line

**1.1.1.3
pitch zone**

geometrical zone containing all of the pitch lines

Note 1 to entry: See [Figure 3](#).

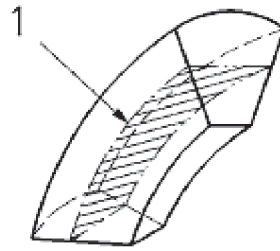
**Key**

1 pitch zone

Figure 3 — Pitch zone**1.1.1.4****pitch width** w_p

width of the belt at its pitch zone (neutral zone)

Note 1 to entry: The width remains unchanged when the belt is bent perpendicularly to its base.

Note 2 to entry: See [Figure 4](#).**1.1.1.5****top width** w

larger width of the trapezium outlined on a cross-section

Note 1 to entry: See [Figure 4](#).**1.1.1.6****height**[ISO 1081:2013](#)<https://standards.iteh.ai/catalog/standards/iso/047a281f-3b09-4547-9d48-df17c1c18ee0/iso-1081-2013>

height of the trapezium outlined on a cross-section

Note 1 to entry: See [Figure 4](#).**1.1.1.7****relative height**non-dimensional characteristic calculated as the ratio of height to pitch width (T/w_p)

Note 1 to entry: The approximate relative height of the four types of V-belt is as follows:

- narrow V-belt: 0,9;
- classical V-belt: 0,7;
- half wide V-belt: 0,5;
- wide V-belt: 0,3.

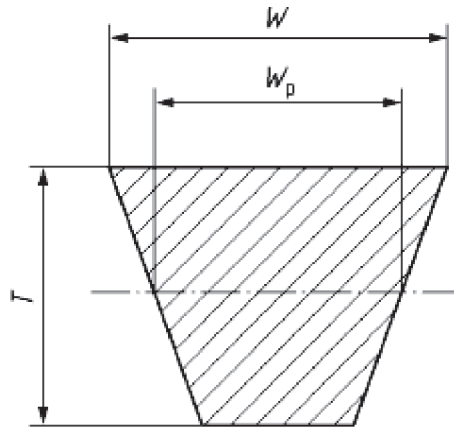

Figure 4 — Pitch width, top width, height

1.1.2 Pulleys

1.1.2.1

V-grooved pulley

pulley with one or more grooves obtained by rotation of a profile in the shape of a truncated or non-truncated symmetrical V around the pulley axis

Note 1 to entry: A round groove bottom is acceptable. In most cases, all the grooves of a pulley have identical profiles.

1.1.2.2

angle of pulley groove

α

angle included by the sides of the groove cross-section

Note 1 to entry: For any given profile, the pulley groove angle may have several different values depending upon the pulley diameter.

Note 2 to entry: See [Figure 5](#).

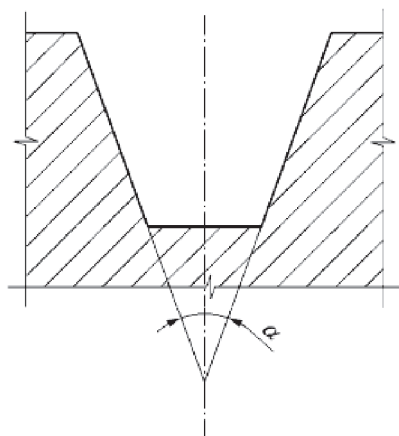

Figure 5 — Angle of pulley groove

1.1.2.3

pitch width of pulley groove

w_p
width of the pulley groove which has the same dimension as the pitch width of the belt used with this pulley

1.1.2.4**pitch diameter** d_p

diameter of the pulley at the pitch width of pulley groove

1.1.2.5**pitch circumference** C_p

circumference of a circle with a diameter equal to the pitch diameter

1.1.3 Drives**1.1.3.1****V-belt drive**

drive which consists of one or more V-belts mounted on grooved pulleys

Note 1 to entry: The profiles of the belts and of the pulley grooves are such that the belts come into contact only with the sides of the pulley grooves and not with the bottom of the grooves.

1.1.3.2**speed ratio** R

ratio of the angular velocities of the pulleys, as calculated from the ratio of the pitch diameters of the pulleys, making no allowance for slip and creep

1.2 Terms and definitions relating to the system based on data widths**1.2.1 Pulleys****1.2.1.1****datum width** w_d

groove width characterizing the groove profile

Note 1 to entry: It is a defined value not subject to tolerance and is usually located at the level of the pitch zone of the V-belt for which the pulley groove is preferably intended. It should coincide with the pitch width of that V-belt within reasonable tolerances.

Note 2 to entry: The datum width of a pulley groove was previously designated as *pitch width* (l_p). However, the datum width is equal to the pitch width only when the pitch zone on the V-belt is located at the level of the datum width of the pulley groove.

Note 3 to entry: If different *angles of pulley groove* (1.1.2.2) are required, the groove flanks shall be assumed to hinge round both ends of the datum width.

Note 4 to entry: See [Figure 6](#).

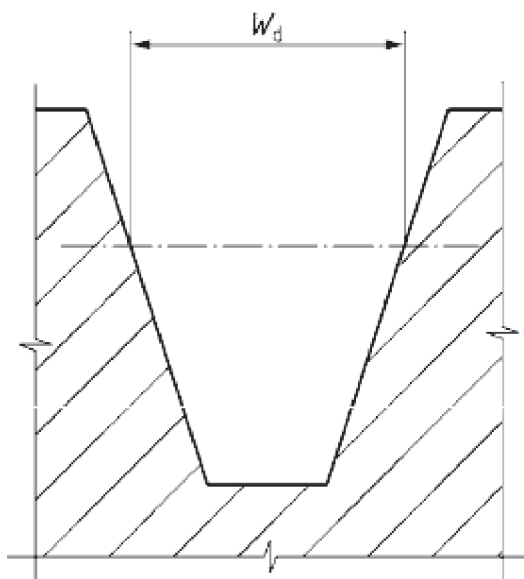

Figure 6 — Datum width

1.2.1.2 datum diameter

d_d
diameter of the pulley at the datum width of the pulley groove

Note 1 to entry: See [Figure 7](#).

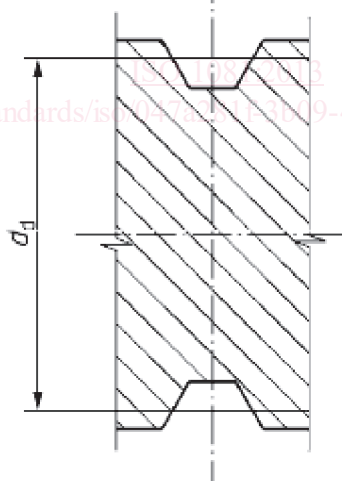

Figure 7 — Datum diameter

1.2.1.3 datum circumference

C_d
circumference of a circle with a diameter equal to the datum diameter

1.2.1.4 datum line differential

b_d

radial displacement between the levels of the pitch width and the datum width

Note 1 to entry: The datum line differential is a correction term used for calculating the speed ratio when the datum line is given.

Note 2 to entry: The datum line differential is zero if the pitch zone of the V-belt and the level of the datum width of the pulley are coincident.

Note 3 to entry: See [Figure 8](#).

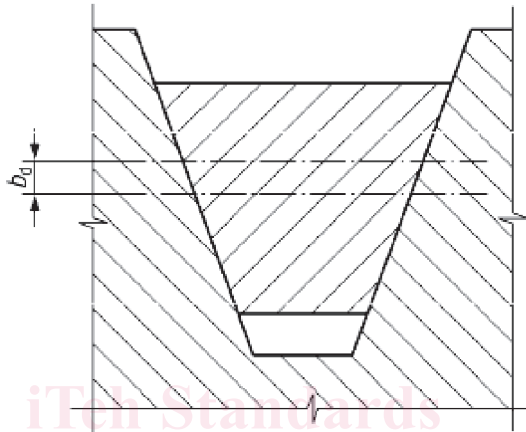

Figure 8 — Datum line differential

1.2.2 Belts

1.2.2.1 datum length

L_d

L_d

length of a line circumscribing a V-belt at the level of the datum diameter of the measuring pulleys whilst the V-belt is at a specified tension

Note 1 to entry: The datum length was previously designated as *pitch length*, L_p .

Note 2 to entry: The recommended method for measuring the datum length of a V-belt includes the use of a measuring fixture having two pulleys of the same datum diameter. The datum length is obtained by adding the datum circumference of one pulley to twice the measured distance between the pulley centres.

1.3 Terms and definitions relating to the system based on effective width

1.3.1 Pulleys

1.3.1.1 effective width

w_e

w_e

groove width characterizing the groove profile

Note 1 to entry: It is a defined value not subject to tolerance and is usually located at the outermost extremities of the straight side walls of the groove.

Note 2 to entry: For all belt-measuring pulleys and for most machined-type pulleys, it coincides with the actual top width of the groove within reasonable tolerances.