



SLOVENSKI STANDARD
SIST EN 16230-1:2014+A1:2015
01-februar-2015

Gokarti za prosti čas - 1. del: Varnostne zahteve in preskusne metode za gokarte

Leisure karts - Part 1: Safety requirements and test methods for karts

Freizeitkarts - Teil 1: Sicherheitstechnische Anforderungen und Prüfverfahren für Karts

Karts de loisir - Partie 1: Exigences de sécurité et méthodes d'essais relatives aux karts

Ta slovenski standard je istoveten z: EN 16230-1:2013+A1:2014

[SIST EN 16230-1:2014+A1:2015](https://standards.iteh.ai/catalog/standards/sist/a7433708-7366-43ba-958d-1480e50ff990/sist-en-16230-1-2014a1-2015)

<https://standards.iteh.ai/catalog/standards/sist/a7433708-7366-43ba-958d-1480e50ff990/sist-en-16230-1-2014a1-2015>

ICS:

43.100	Osebni avtomobili. Bivalne prikolice in lahke prikolice	Passenger cars. Caravans and light trailers
97.220.01	Športna oprema in pripomočki na splošno	Sports equipment and facilities in general

SIST EN 16230-1:2014+A1:2015

en,fr,de

iTeh STANDARD PREVIEW
(standards.iteh.ai)

[SIST EN 16230-1:2014+A1:2015](https://standards.iteh.ai/catalog/standards/sist/a7433708-7366-43ba-958d-1480e50ff990/sist-en-16230-1-2014a1-2015)

<https://standards.iteh.ai/catalog/standards/sist/a7433708-7366-43ba-958d-1480e50ff990/sist-en-16230-1-2014a1-2015>

English Version

Leisure karts - Part 1: Safety requirements and test methods for karts

Karts de loisir - Partie 1: Exigences de sécurité et méthodes d'essais relatives aux karts

Freizeitkarts - Teil 1: Sicherheitstechnische Anforderungen und Prüfverfahren für Karts

This European Standard was approved by CEN on 17 November 2012 and includes Amendment 1 approved by CEN on 18 November 2014.

CEN members are bound to comply with the CEN/CENELEC Internal Regulations which stipulate the conditions for giving this European Standard the status of a national standard without any alteration. Up-to-date lists and bibliographical references concerning such national standards may be obtained on application to the CEN-CENELEC Management Centre or to any CEN member.

This European Standard exists in three official versions (English, French, German). A version in any other language made by translation under the responsibility of a CEN member into its own language and notified to the CEN-CENELEC Management Centre has the same status as the official versions.

CEN members are the national standards bodies of Austria, Belgium, Bulgaria, Croatia, Cyprus, Czech Republic, Denmark, Estonia, Finland, Former Yugoslav Republic of Macedonia, France, Germany, Greece, Hungary, Iceland, Ireland, Italy, Latvia, Lithuania, Luxembourg, Malta, Netherlands, Norway, Poland, Portugal, Romania, Slovakia, Slovenia, Spain, Sweden, Switzerland, Turkey and United Kingdom.

[SIST EN 16230-1:2014+A1:2015](https://standards.iteh.ai/catalog/standards/sist/a7433708-7366-43ba-958d-1480e50ff990/sist-en-16230-1-2014a1-2015)

<https://standards.iteh.ai/catalog/standards/sist/a7433708-7366-43ba-958d-1480e50ff990/sist-en-16230-1-2014a1-2015>



EUROPEAN COMMITTEE FOR STANDARDIZATION
COMITÉ EUROPÉEN DE NORMALISATION
EUROPÄISCHES KOMITEE FÜR NORMUNG

CEN-CENELEC Management Centre: Avenue Marnix 17, B-1000 Brussels

Contents

	Page
Foreword.....	3
Introduction	4
1 Scope	5
2 Normative references	5
3 Terms and definitions	6
4 Classification.....	7
5 Description of the kart.....	8
6 List of significant hazards	10
7 Safety requirements and/or protective measures	12
8 Verification of the safety requirements and/or protective measures	23
9 Information for use	23
Annex A (normative) Measurement methods for kart all round protection system	31
Annex B (normative) Crash test protocol.....	33
Annex C (normative) Brake system performance tests – leisure kart	36
Annex D (normative) Noise emission test.....	43
Annex E (informative) Vibration test methods.....	48
Annex ZA (informative) Relationship between this European Standard and the Essential Requirements of EU Directive 2006/42/EC	52
Bibliography	53

Foreword

This document (EN 16230-1:2013+A1:2014) has been prepared by Technical Committee CEN/TC 354 "Ride-on, motorised vehicles intended for the transportation of persons and goods and not intended for use on public roads - Safety requirements", the secretariat of which is held by AFNOR.

This European Standard shall be given the status of a national standard, either by publication of an identical text or by endorsement, at the latest by June 2015, and conflicting national standards shall be withdrawn at the latest by June 2015.

Attention is drawn to the possibility that some of the elements of this document may be the subject of patent rights. CEN [and/or CENELEC] shall not be held responsible for identifying any or all such patent rights.

This document includes Amendment 1, approved by CEN on 2014-11-18.

This document supersedes EN 16230-1:2013.

The start and finish of text introduced or altered by amendment is indicated in the text by tags \square_{A1} \square_{A1} .

This document has been prepared under a mandate given to CEN by the European Commission and the European Free Trade Association, and supports essential requirements of EU Directive(s).

For relationship with EU Directive(s), see informative Annex ZA, which is an integral part of this document.

This European Standard is one part of the series of standards of EN 16230, *Leisure karts*, consisting of the following parts:

- *Part 1: Safety requirements and test methods for karts* (the present document);
- *Part 2: Safety requirements for tracks*¹⁾.

According to the CEN/CENELEC Internal Regulations, the national standards organizations of the following countries are bound to implement this European Standard: Austria, Belgium, Bulgaria, Croatia, Cyprus, Czech Republic, Denmark, Estonia, Finland, Former Yugoslav Republic of Macedonia, France, Germany, Greece, Hungary, Iceland, Ireland, Italy, Latvia, Lithuania, Luxembourg, Malta, Netherlands, Norway, Poland, Portugal, Romania, Slovakia, Slovenia, Spain, Sweden, Switzerland, Turkey and the United Kingdom.

1) In preparation.

EN 16230-1:2013+A1:2014 (E)**Introduction**

This document is a type C standard as stated in EN ISO 12100 (all parts).

The kart concerned and the extent to which hazards, hazardous situations and hazardous events are covered are indicated in the scope of this document.

When provisions of this type C standard are different from those which are stated in type A or B standards, the provisions of this type C standard take precedence over the provisions of the other standards, for karts that have been designed and built according to the provisions of this type C standard.

**iTeh STANDARD PREVIEW
(standards.iteh.ai)**

[SIST EN 16230-1:2014+A1:2015](https://standards.iteh.ai/catalog/standards/sist/a7433708-7366-43ba-958d-1480e50ff990/sist-en-16230-1-2014a1-2015)

<https://standards.iteh.ai/catalog/standards/sist/a7433708-7366-43ba-958d-1480e50ff990/sist-en-16230-1-2014a1-2015>

1 Scope

This European Standard is applicable for karts, according to 3.1, that are not intended to be used on public roads.

This European Standard applies to:

- leisure karts only;
- karts propelled by a combustion engine, including LPG combustion engines;
- karts used on indoor and outdoor tracks, permanent or temporary;
- karts used on supervised tracks designed for leisure karting, with a sealed ground (such as asphalt, concrete, ice or snow).

This European Standard does not apply to:

- karts used for competition organised by and under the responsibility of the CIK-FIA and/or ASN, ensuring through the granting of licenses by an ASN or one of its affiliated members as defined in the International Sporting code, compliance with the safety, sporting, disciplinary and technical rules of the CIAK-FIA and/or ASN;
- karts designed exclusively for competition and toys;
- cross country karts;
- karts with two or more seats;
- karts used on tracks not mentioned above (such as mud, earth);
- karts used in amusement parks.

The requirements related to the hazards of electrical propulsion are not covered in this European Standard.

The requirements related to whole-body vibration are not covered in this European Standard.

This European Standard specifies appropriate measures to eliminate or reduce the risks arising from significant hazards, hazardous situations and events (see Clause 6) during operation and maintenance of the karts, when carried out as intended by the manufacturer.

Safety in karting activities is dependent on a correct interaction between leisure karts and the track equipment and facilities. General recommendations for tracks to be used for leisure karting are included in this part of the standard.

This document is not applicable to karts that are manufactured before the date of publication of this European Standard by CEN.

NOTE Specific requirements for tracks design and operation will be included in a future Part 2 of this standard.

2 Normative references

The following documents, in whole or in part, are normatively referenced in this document and are indispensable for its application. For dated references, only the edition cited applies. For undated references, the latest edition of the referenced document (including any amendments) applies.

EN 16230-1:2013+A1:2014 (E)

EN ISO 3744:2010, *Acoustics - Determination of sound power levels and sound energy levels of noise sources using sound pressure - Engineering methods for an essentially free field over a reflecting plane (ISO 3744:2010)*

EN ISO 4871, *Acoustics — Declaration and verification of noise emission values of machinery and equipment (ISO 4871)*

EN ISO 11201:2010, *Acoustics - Noise emitted by machinery and equipment - Determination of emission sound pressure levels at a work station and at other specified positions in an essentially free field over a reflecting plane with negligible environmental corrections (ISO 11201:2010)*

EN ISO 12100-1:2003, *Safety of machinery — Basic concepts, general principles for design — Part 1: Basic terminology, methodology (ISO 12100-1:2003)*

EN ISO 12100-2, *Safety of machinery — Basic concepts, general principles for design — Part 2: Technical principles (ISO 12100-2)*

ISO 48, *Rubber, vulcanized or thermoplastic — Determination of hardness (hardness between 10 IRHD and 100 IRHD)*

ISO 3864-1, *Graphical symbols — Safety colours and safety signs — Part 1: Design principles for safety signs and safety markings*

ISO 3864-2, *Graphical symbols — Safety colours and safety signs — Part 2: Design principles for product safety labels*

CR 1030-1, *Hand-arm vibration — Guidelines for vibration hazards reduction — Part 1: Engineering methods by design of machinery*

iTeh STANDARD PREVIEW

(standards.iteh.ai)

[SIST EN 16230-1:2014+A1:2015](https://standards.iteh.ai/catalog/standards/sist/a7433708-7366-43ba-958d-1480e50ff990/sist-en-16230-1-2014a1-2015)

<https://standards.iteh.ai/catalog/standards/sist/a7433708-7366-43ba-958d-1480e50ff990/sist-en-16230-1-2014a1-2015>

3 Terms and definitions

For the purposes of this document, the terms and definitions given in EN ISO 12100-1:2003 and the following applies.

3.1**kart**

multilane motor driven sports equipment, with four wheels not set in a straight line, two wheels of which are powered and the other two serving as control, and without suspension

3.2**leisure karting**

organised activity, offering leisure services in karting including leisure competition

3.3**leisure kart**

kart intended and designed for leisure karting activities

3.4**all around protection**

device made of one or several parts encircling the kart and meant to protect the driver and the kart from external impacts, so as to eliminate the risk of wheel to kart contact

3.5**evaluation**

assessment of the ability of a person to drive

3.6**training**

teaching process by which a driver is brought to an appropriate level of driving standard for the session or event he or she is participating

3.7**track**

sealed ground consisting of a series of loops and straights that are continuous, designed and operated to provide safe driving of karts and located in an area of land or building that is separated from the public by a barrier

3.8**slow track**

track designed and operated to provide safe driving of karts up to 70 km/h

3.9**fast track**

track designed and operated to provide safe driving of karts up to 110 km/h

3.10**Liquified Petroleum Gas****LPG**

mixture of propane and butane which is suitable as power fuel for combustion engines and fluid at room temperature and overpressure

iTeh STANDARD PREVIEW
(standards.iteh.ai)

4 Classification

Leisure karting covers a wide range of activities on indoor and outdoor tracks, and can be used by drivers of different age, size, weight and experience.

<https://standards.iteh.ai/catalog/standards/sist/a7433708-7366-43ba-958d-1489-508990/sist-en-16230-1-2014-a1-2015>

For the purpose of this document, different types of karts have been defined. Table 1 below defines the major design parameters to be taken as a reference by the kart manufacturer for each kart type.

A1

Table 1 — Type of kart - Manufacturers design parameters

Kart type	Slow track kart ^a Maximum speed km/h	Fast track kart ^a Maximum speed km/h	Reference height of driver (ergonomy minimum size ranges for given type) mm	Driver weight range kg	Maximum power at the crankshaft kW ^d	Reference dummy ^e
Kart type A1 (baby ^f)	30	30	1 150 (- 100 / + 100) ^b	22 (- 5 / + 10) ^b	3,5	-
Kart type A2 (mini)	45	65	1 350 (- 150 / + 150) ^b	32 (- 10 / + 18) ^b	5,15	5 th percentile female
Kart type B (adult)	70	80	1 700 (- 250 / + 250) ^b	78 (- 38 / + 23 ^c) ^b	10,3	95 th percentile male
Kart type C1 (adult)	70	90	1 700 (- 250 / + 250) ^b	78 (- 38 / + 23 ^c) ^b	16,9	95 th percentile male
Kart type C2 (adult)	70	110	1 700 (- 250 / + 250) ^b	78 (- 38 / + 23 ^c) ^b	22,1	95 th percentile male

^a Engineering design values; it is assumed that karts are used in conjunction with a track designed for their maximum speed. In some countries, specific regulations may apply regarding age, speed limitation, intended use or dedicated areas.

^b Range specified according to the relevant 50th percentile dummy.

^c Upper tolerance specified according to the 95th percentile male dummy.

^d Measured according to a generally acknowledged standardised method, e.g. ISO 15550, SAE J1349.

^e Hybrid III type dummies used for the crash test as described in B.3.

^f smallest category of a kart.

A1

NOTE See also Table 6 in 9.2.2.3.

5 Description of the kart

The main components of the karts are described in Figure 1.

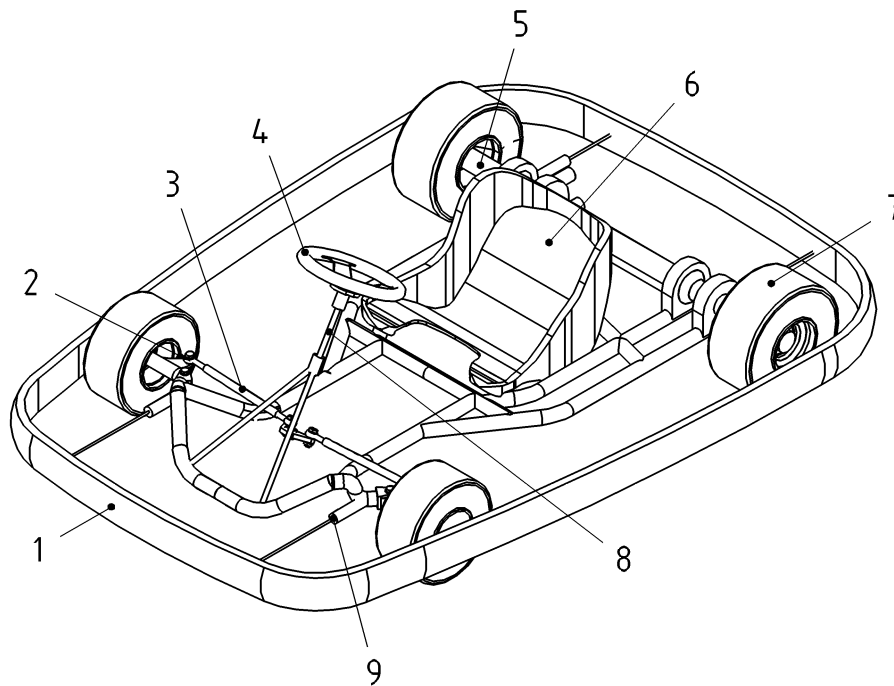
**Key**

- 1 all around protection
- 2 stub axle
- 3 track rods
- 4 steering wheel
- 5 rear train
- 6 seat
- 7 wheel
- 8 steering axle
- 9 energy absorption device

iTeh STANDARD PREVIEW
(standards.iteh.ai)

[SIST EN 16230-1:2014+A1:2015](https://standards.iteh.ai/catalog/standards/sist/a7433708-7366-43ba-958d-1480e50ff990/sist-en-16230-1-2014a1-2015)

<https://standards.iteh.ai/catalog/standards/sist/a7433708-7366-43ba-958d-1480e50ff990/sist-en-16230-1-2014a1-2015>

Figure 1 — Names of the components of the kart

6 List of significant hazards

Table 2 below contains all significant hazards, hazardous situations and events, as far as they are dealt with in this document, and identified by risk assessment as significant for the karts within the scope of this standard and which require action to eliminate or reduce the risk.

Table 2 — List of significant hazards

Subclauses	Danger zone or source of hazard	Type of hazard	Relevant clause of this standard
6.1	Mechanical hazards		
6.1.1	Protection of the kart	Wheel to wheel, or plastic/metal to wheel contact leading to a "launching" type of roll over	7.4.1 Kart protection
		Karts "climbing" one on the other	7.4.1 Kart protection
		Crash situations leading to high forces on the driver	7.4.1 Kart protection
6.1.2	Seat	Falling on the side under centrifugal forces	7.4.2 Seat
		Non efficient braking due to bad position of the driver	
		Lack of control due to bad driving position	
		Falling aside under lateral crash	
6.1.3	Brake system mechanical	Crash situation resulting from a failure of brake systems	7.4.3 Brake system performance
	Brake system hydraulic		7.5.1 Brake system controls
6.1.4	Steering system	Crash situation resulting from a failure of steering system	
	Steering wheel	Projection of the driver against the steering wheel, resulting from a frontal crash	7.5.2 Steering wheel
6.1.5	Stub axle	Crash situation resulting from a failure of a stub axle	7.6 Protection against break up during operation – stub axle
6.1.6	Sharp edges (whole kart)	Injuries due to sharp edges under: — normal situations — crash situations	7.7 Protection against sharp and edges angles
6.1.7	Rotating elements	Hair entanglement in moving parts, especially in rear axle	7.8 Protection against rotating parts
	Rear axle	Loose (floating) clothes entanglement in rotating parts	
	Transmission Brake disk	Risk of inadvertent contact of the body of the driver (e.g. hand) with rotating parts	9.4 Signs (pictogram), written warnings

Subclauses	Danger zone or source of hazard	Type of hazard	Relevant clause of this standard
6.1.8	Stability	Flip over of the kart resulting from excessive grip	7.12 Wheels and tyres
6.2	Electrical hazards		
	Starter batteries and/or 2 nd systems (not propulsion), if any	Fire caused by short circuits	7.18 Starter batteries and 2 nd systems (not propulsion)
		Electrical risks of the power source (charger)	7.18 Starter batteries and 2 nd systems (not propulsion)
6.3	Thermal hazard		
	All high temperature components	Burns due to inadvertent contacts with hot parts	7.9 Protection against hot surfaces
6.4	Noise		
	Whole kart	Risk for the driver, due to close source of noise	7.15 Noise
		Risk for other persons than the driver due to fleet of karts	7.15 Noise
6.5	Vibrations hazards		
	Whole kart	Risk for the driver, due to sources of vibration	7.16 Vibrations hazards
6.6	Material / substance hazards		
6.6.1	Fuel system	Fire or explosion due to damage on fuel system after impacts	7.14.1 Fuel tank
	Fuel tank		
	Fuel line	Fire or explosion due to filling	7.14.2 Fuel lines
6.6.2	LPG system	Fire or explosion due to filling	7.13 Specific requirements for LPG karts
	LPG tank LPG line	Fire or explosion due to damage on fuel system after impacts	7.13 Specific requirements for LPG karts
6.6.3	Starter batteries and/or 2 nd systems (not propulsion), if any	Electrolyte of batteries spilled or projected due to battery failure	7.18 Starter batteries and batteries for second systems (not propulsion)
6.6.4	Indoor facilities. Requirements on karts is an open question	Risk for the driver when exposed to gas emissions , in particular to carbon monoxide	7.17 Gas emission
		Risk for the other persons than driver when exposed to gas emissions, in particular to carbon monoxide	7.17 Gas emission
6.7	Ergonomics hazards		
6.7.1	Pedals means of adjustment	Loss of control due to bad ergonomics leading to crash	7.10 Protection against incorrect action on control

EN 16230-1:2013+A1:2014 (E)

Subclauses	Danger zone or source of hazard	Type of hazard	Relevant clause of this standard
	Pedals	situations	systems
	Pedal Brake Pedal Throttle	Crash situation resulting from incorrect action on pedal / failure of brake pedal	7.10 Protection against incorrect action on control systems
6.7.2	Steering system	Crash situation resulting from a failure of steering system	7.5.2 Steering wheel
6.7.3	Steering wheel	Injury due to steering wheel bad design	7.5.2 Steering wheel

7 Safety requirements and/or protective measures

7.1 General

Karts shall comply with the safety requirements and/or protective measures of this clause. In addition, the kart shall be designed according to the principles of EN ISO 12100 (all parts) for relevant but not significant hazards, which are not dealt with by this document.

7.2 Dimensions requirements

The dimensions of the kart shall meet the requirements of Table 3.

Table 3 — Dimensions of the kart

SIST EN 16230-1:2014+A1:2015

Dimensions in mm

	Maximum Total length L/mm	Maximum Total width B/mm	Minimum Wheel base A/mm	Minimum Rear wheel track ^a to wheel base ratio ^b	Minimum Front wheel track ^a to wheel base ratio ^c
Kart Type A1	1 700	1 300	700	1	0,8
Kart Type A2	2 000	1 400	800	1	0,8
Others (B, C1, C2)	2 200	1 500	900	1	0,8

^a The measurement of the track is taken from centre of the wheel to centre of the wheel.

^b The minimum rear wheel track dimension is the actual wheelbase multiplied by the minimum rear wheel track to wheel base ratio.

^c The minimum front wheel track dimension is the actual wheel base multiplied by the minimum front wheel track to wheel base ratio.

7.3 Materials and products

No part or system shall contain asbestos or other materials endangering persons' safety or health.

7.4 Protection against mechanical hazards

7.4.1 Kart protection

7.4.1.1 General requirements for all-around protection

All around protection shall be provided that:

- prevents wheel to kart contact and, therefore, the launching effect,
- ensures impact stability, e.g. reduces the risk of karts climbing one on the other, of karts rolling over, of karts going under track protection,
- reduces the effect of impact loads on the driver,
- reduces the effects of impact loads on the frame and components.

The relevant dimensions of the protection are described in Figure 2 and the requirements are specified in Table 4.

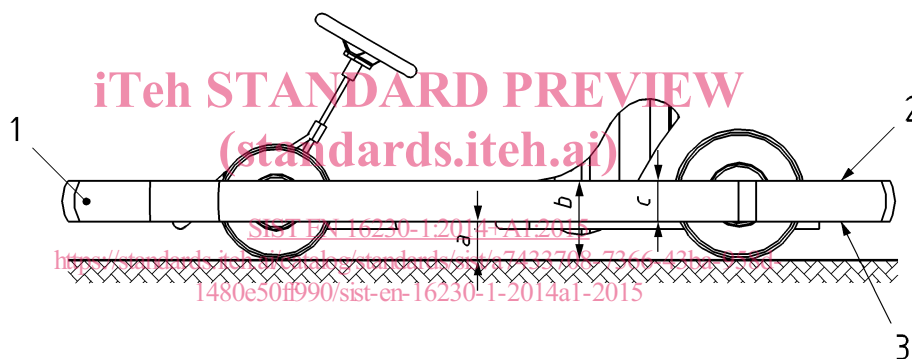

Key

- 1 all around protection (see Table 4)
- 2 upper edge of the all around protection (see Table 4)
- 3 bottom edge of the all around protection (see Table 4)
- a bottom edge height of the all around protection
- b upper edge height of the all around protection
- c depth of the all around protection

Figure 2 — Dimensions of the all around protection

The dimensions a, b and c of the all-around protection shall be in accordance with the values given at Table 4 at all positions around the kart.

Compliance with Table 4 shall be verified, as a minimum, by the measurement of the dimensions a, b and c at the 12 positions defined in Figure 4.

NOTE Table 4 can only be applied directly to all-around protection having a flat vertical contact surface. See 7.4.1.2 for other contact surfaces.