



Designation: C 78 – 08

# Standard Test Method for Flexural Strength of Concrete (Using Simple Beam with Third-Point Loading)<sup>1</sup>

This standard is issued under the fixed designation C 78; the number immediately following the designation indicates the year of original adoption or, in the case of revision, the year of last revision. A number in parentheses indicates the year of last reapproval. A superscript epsilon ( $\epsilon$ ) indicates an editorial change since the last revision or reapproval.

*This standard has been approved for use by agencies of the Department of Defense.*

## 1. Scope\*

1.1 This test method covers the determination of the flexural strength of concrete by the use of a simple beam with third-point loading.

1.2 The values stated in inch-pound units are to be regarded as the standard. The SI equivalent of inch-pound units has been rounded where necessary for practical application.

1.3 *This standard does not purport to address all of the safety concerns, if any, associated with its use. It is the responsibility of the user of this standard to establish appropriate safety and health practices and determine the applicability of regulatory limitations prior to use.*

## 2. Referenced Documents

2.1 *ASTM Standards:*<sup>2</sup>

C 31/C 31M Practice for Making and Curing Concrete Test Specimens in the Field

C 42/C 42M Test Method for Obtaining and Testing Drilled Cores and Sawed Beams of Concrete

C 192/C 192M Practice for Making and Curing Concrete Test Specimens in the Laboratory

C 617 Practice for Capping Cylindrical Concrete Specimens

C 1077 Practice for Laboratories Testing Concrete and Concrete Aggregates for Use in Construction and Criteria for Laboratory Evaluation

E 4 Practices for Force Verification of Testing Machines

## 3. Significance and Use

3.1 This test method is used to determine the flexural strength of specimens prepared and cured in accordance with Test Methods C 42/C 42M or Practices C 31/C 31M or C 192/C 192M. Results are calculated and reported as the modulus of

rupture. The strength determined will vary where there are differences in specimen size, preparation, moisture condition, curing, or where the beam has been molded or sawed to size.

3.2 The results of this test method may be used to determine compliance with specifications or as a basis for proportioning, mixing and placement operations. It is used in testing concrete for the construction of slabs and pavements.

## 4. Apparatus

4.1 The testing machine shall conform to the requirements of the sections on Basis of Verification, Corrections, and Time Interval Between Verifications of Practices E 4. Hand operated testing machines having pumps that do not provide a continuous loading in one stroke are not permitted. Motorized pumps or hand operated positive displacement pumps having sufficient volume in one continuous stroke to complete a test without requiring replenishment are permitted and shall be capable of applying loads at a uniform rate without shock or interruption.

4.2 *Loading Apparatus*—The third point loading method shall be used in making flexure tests of concrete employing bearing blocks which will ensure that forces applied to the beam will be perpendicular to the face of the specimen and applied without eccentricity. A diagram of an apparatus that accomplishes this purpose is shown in Fig. 1.

4.2.1 All apparatus for making flexure tests of concrete shall be capable of maintaining the specified span length and distances between load-applying blocks and support blocks constant within  $\pm 0.05$  in. ( $\pm 1.3$  mm).

4.2.2 The ratio of the horizontal distance between the point of application of the load and the point of application of the nearest reaction to the depth of the beam shall be  $1.0 \pm 0.03$ .

4.2.3 If an apparatus similar to that illustrated in Fig. 1 is used: the load-applying and support blocks should not be more than  $2\frac{1}{2}$  in. (64 mm) high, measured from the center or the axis of pivot, and should extend entirely across or beyond the full width of the specimen. Each case-hardened bearing surface in contact with the specimen shall not depart from a plane by more than 0.002 in. (0.05 mm) and shall be a portion of a cylinder, the axis of which is coincidental with either the axis of the rod or center of the ball, whichever the block is pivoted upon. The angle subtended by the curved surface of each block

<sup>1</sup> This test method is under the jurisdiction of ASTM Committee C09 on Concrete and Concrete Aggregates and is the direct responsibility of Subcommittee C09.61 on Testing for Strength.

Current edition approved Feb. 1, 2008. Published February 2008. Originally approved in 1930. Last previous edition approved in 2007 as C 78 – 07.

<sup>2</sup> For referenced ASTM standards, visit the ASTM website, [www.astm.org](http://www.astm.org), or contact ASTM Customer Service at [service@astm.org](mailto:service@astm.org). For *Annual Book of ASTM Standards* volume information, refer to the standard's Document Summary page on the ASTM website.

\*A Summary of Changes section appears at the end of this standard.

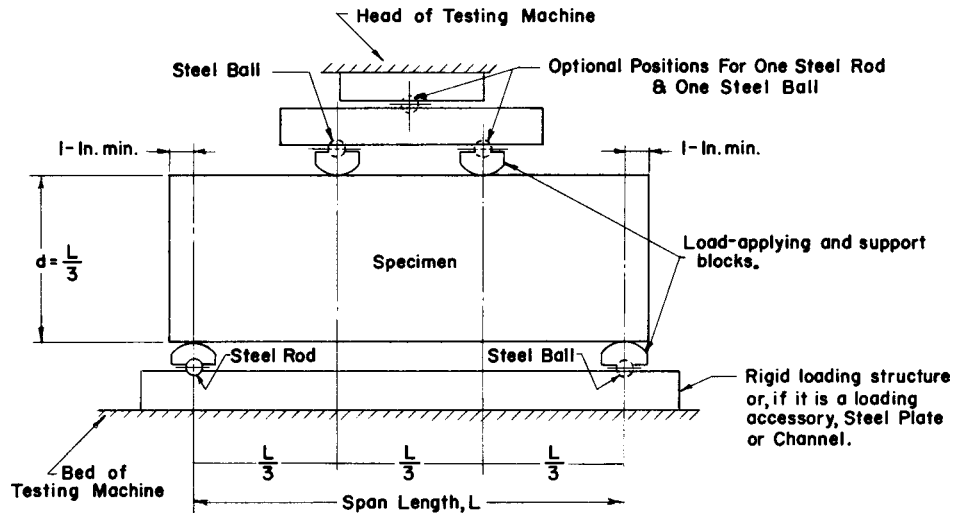

NOTE 1—This apparatus may be used inverted. If the testing machine applies force through a spherically seated head, the center pivot may be omitted, provided one load-applying block pivots on a rod and the other on a ball.

NOTE 2—1 in. = 25.4 mm.

FIG. 1 Diagrammatic View of a Suitable Apparatus for Flexure Test of Concrete by Third-Point Loading Method

should be at least  $45^\circ$  (0.79 rad). The load-applying and support blocks shall be maintained in a vertical position and in contact with the rod or ball by means of spring-loaded screws that hold them in contact with the pivot rod or ball. The uppermost bearing plate and center point ball in Fig. 1 may be omitted when a spherically seated bearing block is used, provided one rod and one ball are used as pivots for the upper load-applying blocks.

## 5. Testing

5.1 The test specimen shall conform to all requirements of Test Method C 42/C 42M or Practices C 31/C 31M or C 192/C 192M applicable to beam specimens and shall have a test span within 2 % of being three times its depth as tested. The sides of the specimen shall be at right angles with the top and bottom. All surfaces shall be smooth and free of scars, indentations, holes, or inscribed identification marks.

5.2 The individual who tests concrete beams for acceptance testing shall meet the concrete laboratory technician requirements of Practice C 1077 including Test Method C 78 as a relevant test.

## 6. Procedure

6.1 Flexural tests of moist-cured specimens shall be made as soon as practical after removal from moist storage. Surface drying of the specimen results in a reduction in the measured flexural strength.

6.2 When using molded specimens, turn the test specimen on its side with respect to its position as molded and center it on the support blocks. When using sawed specimens, position the specimen so that the tension face corresponds to the top or bottom of the specimen as cut from the parent material. Center the loading system in relation to the applied force. Bring the load-applying blocks in contact with the surface of the specimen at the third points and apply a load of between 3 and 6 % of the estimated ultimate load. Using 0.004 in. (0.10 mm) and

0.015 in. (0.38 mm) leaf-type feeler gages, determine whether any gap between the specimen and the load-applying or support blocks is greater or less than each of the gages over a length of 1 in. (25 mm) or more. Grind, cap, or use leather shims on the specimen contact surface to eliminate any gap in excess of 0.004 in. (0.10 mm) in width. Leather shims shall be of uniform  $\frac{1}{4}$  in. (6.4 mm) thickness, 1 to 2 in. (25 to 50 mm) width, and shall extend across the full width of the specimen. Gaps in excess of 0.015 in. (0.38 mm) shall be eliminated only by capping or grinding. Grinding of lateral surfaces should be minimized inasmuch as grinding may change the physical characteristics of the specimens. Capping shall be in accordance with the applicable sections of Practice C 617.

6.3 Load the specimen continuously and without shock. The load shall be applied at a constant rate to the breaking point. Apply the load at a rate that constantly increases the maximum stress on the tension face between 125 and 175 psi/min (0.86 and 1.21 MPa/min) until rupture occurs. The loading rate is calculated using the following equation:

$$r = Sbd^2/L \quad (1)$$

where:

$r$  = loading rate, lb/min (N/min),

$S$  = rate of increase in maximum stress on the tension face, psi/min (MPa/min),

$b$  = average width of the specimen as oriented for testing, in. (mm),

$d$  = average depth of the specimen as oriented for testing, in. (mm), and

$L$  = span length, in. (mm).

## 7. Measurement of Specimens After Test

7.1 To determine the dimensions of the specimen cross section for use in calculating modulus of rupture, take measurements across one of the fractured faces after testing. The width and depth are measured with the specimen as oriented