



Designation: D4543 – 08

# Standard Practices for Preparing Rock Core as Cylindrical Test Specimens and Verifying Conformance to Dimensional and Shape Tolerances<sup>1</sup>

This standard is issued under the fixed designation D4543; the number immediately following the designation indicates the year of original adoption or, in the case of revision, the year of last revision. A number in parentheses indicates the year of last reapproval. A superscript epsilon ( $\epsilon$ ) indicates an editorial change since the last revision or reapproval.

## 1. Scope\*

1.1 These practices specify procedures for laboratory rock core test specimen preparation of rock core from drill core and block samples for strength and deformation testing and for determining the conformance of the test specimen dimensions with tolerances established by this practice. Cubical, rectangular, or other shapes are not covered by this practice. However, some of the information contained within this practice and in standard Test Method C170 may still be of use to preparing other test specimen shapes.

1.2 Rock is a complex engineering material that can vary greatly as a function of lithology, stress history, weathering, moisture content and chemistry, and other natural geologic processes. As such, it is not always possible to obtain or prepare rock core specimens that satisfy the desirable tolerances given in this practice. Most commonly, this situation presents itself with weaker, more porous, and poorly cemented rock types and rock types containing significant or weak (or both) structural features. For these and other rock types which are difficult to prepare, all reasonable efforts shall be made to prepare a specimen in accordance with this practice and for the intended test procedure. However, when it has been determined by trial that this is not possible, prepare the rock specimen to the closest tolerances practicable and consider this to be the best effort (Note 1) and report it as such and if allowable or necessary for the intended test, capping the ends of the specimen as discussed in this practice is permitted.

NOTE 1—Best effort in surface preparation refers to the use of a well-maintained surface grinder, lathe or lapping machine by an experienced operator in which a reasonable number of attempts has been made to meet the tolerances required in this procedure.

1.3 This practice covers some, but not all of the curatorial issues that should be implemented. For curatorial issues that should be followed before and during specimen preparation

<sup>1</sup> These practices are under the jurisdiction of ASTM Committee D18 on Soil and Rock and are the direct responsibility of Subcommittee D18.12 on Rock Mechanics.

Current edition approved Jan. 1, 2008. Published February 2008. Originally approved in 1985. Last previous edition approved in 2007 as D4543 – 07. DOI: 10.1520/D4543-08.

refer to Practices D5079 and to the specific test standards in section 2.1 for which the specimens are being prepared.

1.4 This practice also prescribes tolerance checks on the length-to-diameter ratio, straightness of the elements on the cylindrical surface, the flatness of the end bearing surfaces, and the perpendicularity of the end surfaces with the axis of the core.

1.5 The requirement for specifying the moisture condition of the test specimen is also stated. However, the requirements in the specific test standards in section 2.1 should be followed too.

1.6 All observed and calculated values shall conform to the guidelines for significant digits and rounding established in Practice D6026, unless superseded by this standard.

1.6.1 The practices/procedures used to specify how data are collected/recorded and calculated in this standard are regarded as the industry standard. In addition, they are representative of the significant digits that generally should be retained. The procedures used do not consider material variation, purpose for obtaining the data, special purpose studies, or any considerations for the user's objectives; and it is common practice to increase or reduce significant digits of reported data to be commensurate with these considerations. It is beyond the scope of this standard to consider significant digits used in analysis methods for engineering design.

1.7 Units—The dimensional values stated in either inch-pound units or SI units are to be regarded as standard, such as 4 to 12 in. or 100 to 300 mm. The values stated in each system may not be exact equivalents; therefore, each system shall be used independently of the other. Combining values from the two systems may result in non-conformance with the standard. (Note, when mass measurements are added to determine densities or unit weights, add the following.)

1.7.1 Only the SI units are used for mass determinations, calculations and reported results. However, the use of balances or scales recording pounds of mass (lbm) shall not be regarded as nonconformance with this standard.

1.8 *This standard does not purport to address all of the safety concerns, if any, associated with its use. It is the*

\*A Summary of Changes section appears at the end of this standard

responsibility of the user of this standard to establish appropriate safety and health practices and determine the applicability of regulatory limitations prior to use.

1.9 These practices offer a set of instructions for performing one or more specific operations. This document cannot replace education or experience and should be used in conjunction with professional judgement. Not all aspects of this practice may be applicable in all circumstances. This ASTM standard is not intended to represent or replace the standard of care by which the adequacy of a given professional service must be judged, nor should this document be applied without consideration of a project's many unique aspects. The word "standard" in the title of this document means only that the document has been approved through the ASTM consensus process.

## 2. Referenced Documents

### 2.1 ASTM Standards:<sup>2</sup>

**C170** Test Method for Compressive Strength of Dimension Stone

**C617** Practice for Capping Cylindrical Concrete Specimens

**D653** Terminology Relating to Soil, Rock, and Contained Fluids

**D2113** Practice for Rock Core Drilling and Sampling of Rock for Site Exploration

**D2216** Test Methods for Laboratory Determination of Water (Moisture) Content of Soil and Rock by Mass

**D2936** Test Method for Direct Tensile Strength of Intact Rock Core Specimens

**D3740** Practice for Minimum Requirements for Agencies Engaged in Testing and/or Inspection of Soil and Rock as Used in Engineering Design and Construction

**D5079** Practices for Preserving and Transporting Rock Core Samples

**D6026** Practice for Using Significant Digits in Geotechnical Data

**D7012** Test Methods for Compressive Strength and Elastic Moduli of Intact Rock Core Specimens under Varying States of Stress and Temperatures

**D7070** Test Methods for Creep of Rock Core Under Constant Stress and Temperature

## 3. Terminology

3.1 For terminology used in this test method, refer to Terminology **D653**

## 4. Significance and Use

4.1 The dimensional, shape, and surface tolerances of rock core specimens are important for determining rock properties of intact specimens. This is especially true for strong rocks, greater than 7250 psi (50 MPa). Dimensional and surface tolerance checks are required in the test methods listed in Section 2.1. To simplify test procedures in laboratories, the

parts of those procedures that are common to the test methods in Section 2.1 are given in this standard.

4.2 This procedure is applicable to all the standards listed in Section 2.1. However, specimens for Test Method **D2936** do not need to be machined or to meet the specified tolerances for flatness and parallelism.

4.3 The moisture condition of the specimen at the time of the sample preparation can have a significant effect upon the strength and deformation characteristics of the rock. Good practice generally dictates that laboratory tests be made upon specimens representative of field conditions. Thus, it follows that the field moisture condition of the specimen should be preserved until the time of the test. In some instances, however, there may be reasons for testing specimens at other moisture contents, from saturation to dry. In any case, the moisture content of the test specimen should be tailored to the problem at hand. Excess moisture will affect the adhesion of resistance strain gages, if used, and the accuracy of their performance. Adhesives used to bond the rock to steel end pieces in the direct tension test will also be affected adversely by excess moisture.

NOTE 2—The quality of the result produced by these practices is dependent upon the competence of the personnel performing it and the suitability of the equipment and facilities used. Agencies that meet the criteria of Practice **D3740** are generally considered capable of competent and objective testing and sampling. Users of these practices are cautioned that compliance with Practice **D3740** does not in itself assure reliable results. Reliable results depend on many factors; Practice **D3740** provides a means of evaluating some of those factors.

## 5. Apparatus

5.1 *Support Surface*—A flat test surface which shall not depart from a plane by more than 0.0005 in. (0.0013 mm) upon which the cylindrical sides of a rock core test specimen may be rolled and a V-block end of a rock core test specimen, displacement gage assembly, or both, is placed, the tolerance of . Machinist grade, certified, granite blocks are commonly used for support surfaces because they do not dent or rust. However, other materials may be used if they meet the criteria of the procedure. The area of the support surface will depend on the size of specimens to be prepared, however, a 12 in. × 12 in. (300 mm × 300 mm) area will be sufficient for most applications.

5.2 *V-block (conformance tests)*—The V-block shall be machinist quality with all bearing faces surfaces ground flat, smooth to within 0.0005 in. (13 μm) and with a 90° included angle. The V-block shall have some means of securing the specimen firmly in the V-block. The dimensions of the V-block must be such that it does not physically interfere with the displacement gage readings.

### 5.3 *Displacement Gage Assembly* :

5.3.1 *Dial or Electronic Displacement Gage*—The sensitivity of the displacement gage shall be at least 0.001 in. (0.02 mm) for measurement of cylindrical surfaces. The measurement contact tip of the displacement gage shall be round in shape. A displacement gage readable to 0.0001 in. (0.002 mm) is required for measurements on the end surfaces.

<sup>2</sup> For referenced ASTM standards, visit the ASTM website, www.astm.org, or contact ASTM Customer Service at service@astm.org. For *Annual Book of ASTM Standards* volume information, refer to the standard's Document Summary page on the ASTM website.

5.3.2 *Dial or Electronic Displacement gage Stand*—A stand with a base and vertically mounted rod with an adjustable gage holder to support the gage on the flat surface at the proper height for the specimen and to take measurements normal to the flat surface. The side of the base can be machined flat so that it may be used as a straight edge for taking measurements as shown in Fig. 1 and described in Section 9.1.

5.4 *Feeler Gage Set*—25 or 26 leaf/blade set; 3 in. long by ½ in. wide, and thicknesses beginning at 0.015 in. and ending at 0.025 in. or 25 or 26 leaf/blade set; 75-76 mm long by 12.7-15 mm wide, and thicknesses beginning at 0.04 mm and ending at 1.00 mm.

5.5 *Surface Grinder*—A manual or automatic machinist's surface grinder equipped with a grinding wheel suited for the specimen, a magnetic flat surface and a special V-block to hold the sample during the grinding process. The apparatus is also equipped to apply appropriate cooling and cutting agents (if needed) at the cutting surface to cool the grinding wheel surface and wash away cuttings.

5.6 *V-Block (Grinder)*—A metal V-block for holding the rock specimen in the surface grinder on the magnetic chuck and is configured so that the specimen can be rotated to grind both ends without interfering with the grinding process.

5.7 *Diamond Saw*—A rock saw equipped with a segmented circular diamond saw blade, with a moveable platform for holding and feeding the sample, perpendicular to the core axis, into the cutting surface of the blade. The moveable platform may be a manual or automatic feed. The apparatus is also equipped to apply appropriate cooling and cutting agents (if needed) at the cutting surface to cool the blade and wash away cuttings.

5.8 *For Drilling Block Samples:*

5.8.1 A 10-horsepower drill, with a GFI (Ground Fault Interrupt) for electrical powered drills.

5.8.2 A thin walled diamond core barrel.

5.8.3 A water swivel and adaptors for hooking up to the drill.

5.9 (Optional) Lapper.

5.10 (Optional) Machinist Shaper.

5.11 Machinist Calipers, or similar device, with vernier, digital, or dial readouts readable to 0.01 in. (0.25 mm) and large enough for the size of the specimens being measured.

5.12 Miscellaneous Tools: machinist scribe and water proof markers.

6. Samples

6.1 Samples for preparing specimens can be either drill cores obtained directly from the in situ rock or obtained from block samples cored in the field or in the laboratory.

6.2 Samples should be selected or obtained (or both) to meet the objectives of the specific standard listed in 2.1 and the test program and any requirements related to anisotropic properties of the in situ material that are relevant to the intended use.

7. Specimens

7.1 Test specimens shall be right circular cylinders within the tolerances specified herein.

7.2 The specimen shall have a length-to-diameter ratio (L/D) of 2.0 to 2.5 and a diameter of not less than 1-7/8 in. (47 mm).

7.2.1 The larger the internal friction angle of a specimen the more desirable it will be to have larger L/D ratios so that the specimen can potentially develop a true shear plane that does not pass through either end of the specimen or is not altered by the specimen size.

NOTE 3—It is desirable that the diameter of rock test specimens be at least ten times the diameter of the largest mineral grain. For weak rock types which behave more like soil (for example, weakly cemented sandstone), the specimen diameter should be at least six times the maximum particle diameter. It is considered that the specified minimum specimen diameter of approximately 1-7/8 in. (47 mm) will satisfy this criterion in the majority of cases. When cores of diameter smaller than the specified minimum must be tested because of the unavailability of larger diameter core or prohibitive use of large drilling equipment (as is often the case in the mining industry), costs, or both, and suitable notation of this fact shall be made in the report.

7.3 The cylindrical surfaces of the specimen shall be generally smooth and free of abrupt irregularities, with all the elements straight to within 0.020 in. (0.50 mm) over the full length of the specimen, as determined by 9.1, procedure S1 or S2.

7.4 The ends of the specimen shall be cut parallel to each other and at right angles to the longitudinal axis. The end surfaces shall be surface ground or lapped flat to a tolerance not to exceed 0.001 in. (25 µm), as determined by 9.2.<sup>3</sup>

7.5 The use of capping materials or end surface treatments other than the grinding, lathe, and lapping specified herein is not permitted, except as noted in 7.6.

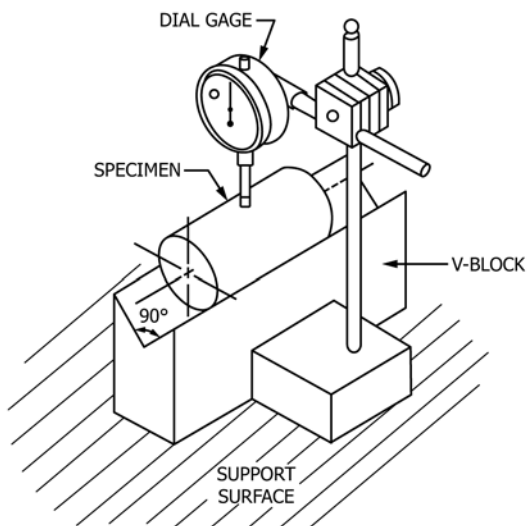

FIG. 1 Assembly for Determining the Straightness of Elements on the Cylindrical Surface (S2)

<sup>3</sup> Hoskins, J. R., and Horino, F. G., "Effects of End Conditions on Determining Compressive Strength of Rock Samples," *Report of Investigations U.S. Bureau of Mines 7171*, 1968.



7.6 There are some rock types with physical characteristics or low strengths which preclude preparing specimens to the flatness tolerance specified in 7.4, even with the best effort (Note 3). In these instances, first cut the core specimen to length, then apply end caps to the end surfaces of the specimen.

7.7 The specifications for the capping compound, capping plates, and alignment devices and the procedure for capping weak rock core specimens shall be the same as those established for compression testing of concrete in Practice C617; however, melted sulfur capping compounds are not permitted because of the possible detrimental effects of the high temperature on the rock. Dental plaster and high strength gypsum cements are commonly used.

7.8 The ends of the specimen shall not depart from perpendicularity to the axis of the specimen by more than 0.25° as determined in Section 9.

7.9 The parallelism tolerance is the maximum angular difference between the opposing best-fit straight line on each specimen end. It shall be not more than 0.25° for spherically seated test machines and 0.13° for fixed end test machines as determined in Section 9.

## 8. Procedure for Preparing Test Specimens

8.1 Specimens can be prepared from either drill cores obtained directly from the in situ rock or obtained from block samples cored in the field or in the laboratory. If block samples are being used then Section 8.2 which describes laboratory coring of specimens from block samples shall be followed before proceeding to Section 8.3. Practice D2113 describes rock core drilling and sampling of rock for site investigations. Water is normally a suitable fluid for rock coring, cutting and grinding operations. However, some rock materials are sensitive to water, the chemistry of the water, or both. For example, using fresh water on saline sedimentary rocks may cause the sample or specimen to fall apart. Therefore, alternate suitable cooling and flushing fluids should be used. In Sections 5.8 and 5.9 an air-cooled grinding unit with a dust collector is recommended for weak rocks and rocks that may react to fluids.

8.2 *Core Drilling Block Samples*—At least a 10 horsepower drill, with a GFI for electrical powered drills is recommended. A thin-walled core barrel with a water swivel and adaptors for hooking up the drill are recommended. Surface set diamond thin-wall bits are suited for soft rock. Impregnated diamond thin-wall bits are better suited for hard rock.

8.2.1 Install the thin-wall bit and water swivel into the drill press chuck. Give the end of the thin-wall bit a tap with a rubber mallet to ensure it is snug.

8.2.2 Lower the thin-wall bit to the drill table and mark the core barrel for reference for sufficient drilling depth.

8.2.3 Connect the cooling fluid hose to the swivel and tie it out of the way.

8.2.4 Place a sheet of ½ in. (12.7 mm) plywood on the drill table. Place and orient if required, the rock block on the plywood and then clamp the rock block securely to the table with clamping devices such as chain vise locks. Block with

wood wedges as necessary to ensure the rock is secure and has a relatively flat surface for drill bit to start cutting on.

8.2.5 Turn on the cooling fluid with sufficient flow to cool the bit and to flush the cuttings.

8.2.6 With the bit raised off the sample, turn on the drill using a slow speed.

8.2.7 Lower the bit slowly onto the sample using a slow rotation speed until a groove is started. Use enough down force to prevent chatter but do not allow the motor to slow so much as to buzz. A loss of drill cooling fluid and the reference position mark indicates the end of the run.

8.2.8 After breaking through, back the bit out of the hole and turn off the drill. If the core is not completely drilled through, remove the block and tap the bottom gently, then remove the core.

8.2.9 Code and store the core.

### 8.3 *Specimen Cutting:*

8.3.1 Automatic feed diamond saws are recommended for cutting large rock specimens.

8.3.2 Clamp the sample in the jig used for holding or feeding the specimen during the cutting process.

8.3.3 Apply cooling fluid continuously to cool the blade and flush cuttings from the cut.

8.3.4 Turn on the saw and use either the manual or automatic feed capabilities of the saw to cut the specimen perpendicular to its axis (see 7.2 and 7.4) at a rate that avoids blade chatter.

8.3.5 Once the specimen is cut, back off the blade and turn off the saw.

8.3.6 Remove, label and store the specimen according to the test program requirements.

NOTE 4—When cutting weak or friable rock such as potash, shale, etc., it is recommended the core be first encapsulated in polyolefin heat shrink tubing before cutting.

8.4 *Cylindrical Surface Grinding*—The quality of the circumferential surfaces of core specimens is usually acceptable for most rock types, and no further surface finishing is required. If the drilled surface contains abrupt irregularities however, further finishing is recommended. This can be accomplished by surface grinding in a lathe in much the same way as dog bone specimens are prepared for direct tensile tests. The lathe chuck and center spindle are fitted with brass centers having knurled end bearing surfaces. The specimen is held between the brass centers by end pressure. A tool post grinder equipped with a diamond impregnated wheel is used to grind the cylindrical surfaces. Diamond impregnated grinding wheels are best suited for grinding rock surfaces. Use cooling fluid to cool the surfaces and wash away cuttings.

8.5 *End Surface Flatness and Parallelism*—There are several ways to prepare the end surfaces of a specimen.

#### 8.5.1 *Method ES1—Surface Grinding:*

8.5.1.1 Using a machinist table grinder, the core is clamped in a V-block, or similar holding jig, suitable for table grinder and placed on the magnetic table.

8.5.1.2 The specimen ends are typically colored with a waterproof marker, prior to the start of grinding, in order to monitor where material is being removed.