**Road vehicles — Vehicle test
methods for electrical disturbances
from narrowband radiated
electromagnetic energy —**

Part 3:

On-board transmitter simulation

iTeh STANDARD PREVIEW

(standards.iteh.ai)
*Véhicules routiers — Méthodes d'essai d'un véhicule soumis
à des perturbations électriques par rayonnement d'énergie
électromagnétique en bande étroite —*

ISO 11451-3:2015

<https://standards.iteh.ai/catalog/standards/sist/6.50-74/42-2a90-40cc-9051-c5819e6260ca/iso-11451-3-2015>

c5819e6260ca/iso-11451-3-2015



iTeh STANDARD PREVIEW
(standards.iteh.ai)

ISO 11451-3:2015

<https://standards.iteh.ai/catalog/standards/sist/6364af42-2a90-46ce-905f-c5819e6260ca/iso-11451-3-2015>



COPYRIGHT PROTECTED DOCUMENT

© ISO 2015, Published in Switzerland

All rights reserved. Unless otherwise specified, no part of this publication may be reproduced or utilized otherwise in any form or by any means, electronic or mechanical, including photocopying, or posting on the internet or an intranet, without prior written permission. Permission can be requested from either ISO at the address below or ISO's member body in the country of the requester.

ISO copyright office
Ch. de Blandonnet 8 • CP 401
CH-1214 Vernier, Geneva, Switzerland
Tel. +41 22 749 01 11
Fax +41 22 749 09 47
copyright@iso.org
www.iso.org

Contents

Page

Foreword	iv
Introduction	v
1 Scope	1
2 Normative references	1
3 Terms and definitions	1
4 Test conditions	1
5 Test location	2
5.1 General.....	2
5.2 Absorber lined shielded enclosure (ALSE).....	2
5.3 Outdoor test site.....	2
6 Test instrumentation	2
6.1 General.....	2
6.2 Signal sources.....	2
6.2.1 Transmitters with antenna outside the vehicle.....	2
6.2.2 Transmitters with antenna inside the vehicle.....	3
6.3 RF power and field monitoring equipment.....	3
6.4 Antennas.....	3
6.4.1 Transmitters with antenna outside the vehicle.....	3
6.4.2 Transmitters with antenna inside the vehicle.....	3
6.5 Stimulation and monitoring of the device under test.....	4
7 Test set-up	4
7.1 Transmitters with antenna outside the vehicle.....	4
7.1.1 Simulated on-board transmitters.....	4
7.1.2 Commercial on-board transmitters.....	6
7.2 Transmitters with antenna inside the vehicle.....	7
7.2.1 General.....	7
7.2.2 Simulated portable transmitters.....	7
7.2.3 Commercial portable transmitters.....	8
8 Test procedure	10
8.1 General.....	10
8.2 Test plan.....	10
8.3 Test method.....	11
8.3.1 Transmitters with antenna outside the vehicle.....	11
8.3.2 Transmitters with antenna inside the vehicle.....	12
8.4 Test report.....	13
Annex A (informative) Typical characteristics of on-board transmitters	14
Annex B (informative) Guidance on tuning antennas on the vehicle for minimum voltage standing wave ratio (VSWR)	17
Annex C (informative) Examples of simulated portable transmitter antennas	20
Bibliography	54

Foreword

ISO (the International Organization for Standardization) is a worldwide federation of national standards bodies (ISO member bodies). The work of preparing International Standards is normally carried out through ISO technical committees. Each member body interested in a subject for which a technical committee has been established has the right to be represented on that committee. International organizations, governmental and non-governmental, in liaison with ISO, also take part in the work. ISO collaborates closely with the International Electrotechnical Commission (IEC) on all matters of electrotechnical standardization.

The procedures used to develop this document and those intended for its further maintenance are described in the ISO/IEC Directives, Part 1. In particular the different approval criteria needed for the different types of ISO documents should be noted. This document was drafted in accordance with the editorial rules of the ISO/IEC Directives, Part 2 (see www.iso.org/directives).

Attention is drawn to the possibility that some of the elements of this document may be the subject of patent rights. ISO shall not be held responsible for identifying any or all such patent rights. Details of any patent rights identified during the development of the document will be in the Introduction and/or on the ISO list of patent declarations received (see www.iso.org/patents).

Any trade name used in this document is information given for the convenience of users and does not constitute an endorsement.

For an explanation on the meaning of ISO specific terms and expressions related to conformity assessment, as well as information about ISO's adherence to the WTO principles in the Technical Barriers to Trade (TBT) see the following URL: [Foreword - Supplementary information](#)

The committee responsible for this document is ISO/TC 22, *Road vehicles*, Subcommittee SC 32, *Electrical and electronic components and general system aspects*.

This third edition cancels and replaces the second edition (ISO 11451-3:2007), which has been technically revised.

ISO 11451 consists of the following parts, under the general title *Road vehicles — Vehicle test methods for electrical disturbances from narrowband radiated electromagnetic energy*:

- *Part 1: General principles and terminology*
- *Part 2: Off-vehicle radiation source*
- *Part 3: On-board transmitter simulation*
- *Part 4: Bulk current injection (BCI)*

[Annexes A, B and C](#) of of this part of ISO 11451 are for information only.

Introduction

In recent years, an increasing number of electronic devices for controlling, monitoring, and displaying a variety of functions have been introduced into vehicle designs. It is necessary to consider the electrical and electromagnetic environment in which these devices operate.

Electrical and radio frequency disturbances occur during the normal operation of many items of motor vehicle equipment. They are generated over a wide frequency range with various electrical characteristics and can be distributed to on-board electronic devices and systems by conduction, radiation, or both. Narrowband signals generated from sources on or off the vehicle can also be coupled into the electrical and electronic system, affecting the normal performance of electronic devices. Such sources of narrowband electromagnetic disturbances include mobile radios and broadcast transmitters.

The characteristics of the immunity of a vehicle to radiated disturbances have to be established. ISO 11451 provides various test methods for the evaluation of vehicle immunity characteristics (not all methods need be used to test a vehicle).

ISO 11451 is not intended as a product specification and cannot function as one. Therefore, no specific values for the test severity level are given.

Protection from potential disturbances needs to be considered in a total system validation, and this can be achieved using the various parts of ISO 11451.

NOTE Immunity measurements of complete vehicles are generally able to be carried out only by the vehicle manufacturer, owing to, for example, high costs of absorber-lined shielded enclosures, the desire to preserve the secrecy of prototypes, or a large number of different vehicle models. ISO 11452 specifies test methods for the analysis of component immunity, which are better suited for supplier use.

[ISO 11451-3:2015](https://standards.iteh.ai/catalog/standards/sist/6364af42-2a90-46ce-905f-c5819e6260ca/iso-11451-3-2015)

<https://standards.iteh.ai/catalog/standards/sist/6364af42-2a90-46ce-905f-c5819e6260ca/iso-11451-3-2015>

iTeh STANDARD PREVIEW
(standards.iteh.ai)

[ISO 11451-3:2015](https://standards.iteh.ai/catalog/standards/sist/6364af42-2a90-46ce-905f-c5819e6260ca/iso-11451-3-2015)

<https://standards.iteh.ai/catalog/standards/sist/6364af42-2a90-46ce-905f-c5819e6260ca/iso-11451-3-2015>

Road vehicles — Vehicle test methods for electrical disturbances from narrowband radiated electromagnetic energy —

Part 3: On-board transmitter simulation

1 Scope

This part of ISO 11451 specifies methods for testing the immunity of passenger cars and commercial vehicles to electromagnetic disturbances from on-board transmitters connected to an external antenna and portable transmitters with integral antennas, regardless of the vehicle propulsion system (e.g. spark ignition engine, diesel engine, electric motor).

2 Normative references

The following documents, in whole or in part, are normatively referenced in this document and are indispensable for its application. For dated references, only the edition cited applies. For undated references, the latest edition of the referenced document (including any amendments) applies.

ISO 11451-1, *Road vehicles — Vehicle test methods for electrical disturbances from narrowband radiated electromagnetic energy — Part 1: General principles and terminology*

ISO 11451-2, *Road vehicles — Vehicle test methods for electrical disturbances from narrowband radiated electromagnetic energy — Part 2: Off-vehicle radiation sources*

3 Terms and definitions

For the purposes of this document, the terms and definitions given in ISO 11451-1 and the following apply.

3.1

integral antenna

permanent fixed antenna which may be built-in, designed as an indispensable part of the portable transmitting device

4 Test conditions

The applicable frequency range of the test method is 1,8 MHz to 5,85 GHz.

The user of this part of ISO 11451 shall specify the test severity level or levels over the frequency bands. Typical on-board transmitter characteristics (frequency bands, power level and modulation) are given in [Annex A](#).

NOTE Users of this part of ISO 11451 should be aware that [Annex A](#) is for information only and cannot be considered as an exhaustive description of various on-board transmitters available in all countries.

Standard test conditions are given in ISO 11451-1 for the following:

- test temperature;
- supply voltage;

ISO 11451-3:2015(E)

- dwell time;
- test signal quality.

5 Test location

5.1 General

This test would typically be performed in an absorber lined shielded enclosure (ALSE). Where national regulations permit, the test can also be performed at an outdoor test site.

5.2 Absorber lined shielded enclosure (ALSE)

An absorber lined shielded enclosure with the characteristics specified in ISO 11451-2 is adequate for this test.

NOTE At frequencies where absorbers are not effective, the reflections in the chamber can affect the exposure of the vehicle.

5.3 Outdoor test site

Where national regulations permit the use of an outdoor test site, the outdoor test site should have an area with a radius of 10 m free from large metal structures or objects. When performing outdoor test-site tests, care shall be taken to ensure that harmonic suppression regulations are met.

6 Test instrumentation

(standards.iteh.ai)

6.1 General

ISO 11451-3:2015
<https://standards.iteh.ai/catalog/standards/sist/6364af42-2a90-46ce-905f-65819e6260ca/iso-11451-3-2015>

The following test instrumentation is used:

- signal sources with internal or external modulation capability;
- power amplifier(s);
- power meter (or equivalent measuring instrument) to measure the forward and reverse power;
- field generating devices: antennas;
- field probes (for environmental monitoring).

6.2 Signal sources

6.2.1 Transmitters with antenna outside the vehicle

Signal sources for transmitters with antenna outside the vehicle can be

- simulated on-board transmitters: use of a signal generator and broadband power amplifier, and
- commercial on-board transmitters installed in vehicle capable of generating radio frequency (RF) power in their operational frequency ranges with specific output power.

NOTE When using simulated on-board transmitters, it is advisable to place an RF choke (ferrite or powdered iron toroid, depending on frequency) around the coaxial cable to the antenna, in order to reduce skin currents and more closely simulate a transmitter installed in the vehicle.

6.2.2 Transmitters with antenna inside the vehicle

Signal sources for transmitters with antenna inside the vehicle can be

- simulated portable transmitters: use of a metallic box with similar dimension to the portable transmitter and amplifier (if needed), and
- commercial portable transmitters with integral antennas.

6.3 RF power and field monitoring equipment

A power meter is required when using simulated on-board transmitters for measuring power to the antenna. Both forward power and reverse power shall be measured and recorded.

6.4 Antennas

6.4.1 Transmitters with antenna outside the vehicle

6.4.1.1 Simulated on-board transmitters

When an original equipment manufacturer (OEM) antenna is not installed on the vehicle, the antenna(s) described below shall be used.

- For frequency ranges lower than 30 MHz, loaded antennas shall be used. Loaded antennas employ lumped or distributed reactive components with a radiating element physically shorter than quarter wave at resonance.
- For frequency ranges higher than 30 MHz, e.g. for the very high frequency (VHF) and ultra-high frequency (UHF) bands, quarter wave antennas should be given preference over 5/8 wave antennas, since there are higher skin currents created by quarter wave antennas.

All antennas shall be tuned on the vehicle for minimum voltage standing wave ratio (VSWR, typically less than 2:1), unless otherwise specified in the test plan. As a minimum, the VSWR value shall be recorded with the antenna on the vehicle at the lower and upper band edge and at a middle frequency (see [Annex B](#) for guidance on influence of cable loss and VSWR).

When an OEM antenna is actually installed on the vehicle, this antenna shall be used for the test in the appropriate frequency range. In this case, the VSWR shall not be adjusted, but shall be recorded.

6.4.1.2 Commercial on-board transmitters

The vehicle OEM antenna shall be used for the test in the appropriate frequency range. In this case, the VSWR shall not be adjusted.

6.4.2 Transmitters with antenna inside the vehicle

6.4.2.1 Simulated portable transmitter

Unless otherwise specified the simulated portable transmitter antenna characteristics shall be a passive antenna as detailed in [C.2](#). Examples of other antennas which can be used are defined in [Annex C](#).

All antennas should have a minimum VSWR (typically less than 4:1), unless otherwise specified in the test plan. As a minimum, the VSWR value shall be recorded at the lower and upper band edge and at a middle frequency.

6.4.2.2 Commercial portable transmitters

When a commercial portable transmitter with integral antenna is used, its antenna shall be used for the test in the appropriate frequency range. In this case, the VSWR shall not be adjusted.

6.5 Stimulation and monitoring of the device under test

If remote stimulation and monitoring are required in the test plan, the vehicle shall be operated by actuators which have a minimum effect on the electromagnetic characteristics, e.g. plastic blocks on the push-buttons, pneumatic actuators with plastic tubes.

Connections to monitoring equipment can be accomplished by using fibre-optics or high resistance leads. Other types of leads can be used, but they require extreme care to minimize interactions. The orientation, length and location of such leads shall be carefully documented to ensure repeatability of test results.

Any electrical connection of monitoring equipment to the vehicle can cause malfunctions of the vehicle. Extreme care shall be taken to avoid such an effect.

7 Test set-up

7.1 Transmitters with antenna outside the vehicle

7.1.1 Simulated on-board transmitters

The test can be performed with test antenna(s) or with the vehicle's OEM antenna, as defined in 6.4.1.1.

When a test antenna is used, the location(s) of the transmitting antenna on the vehicle shall be defined in the test plan. If no specific location(s) are agreed between the users of this part of ISO 11451, the following location (s) are recommended, as illustrated in Figure 1:

- locations 1 (vehicle roof, front) and 2 (vehicle roof, rear) are the default locations for frequencies ≥ 30 MHz;
- location 9 (bumper) is the default location for frequencies < 30 MHz.

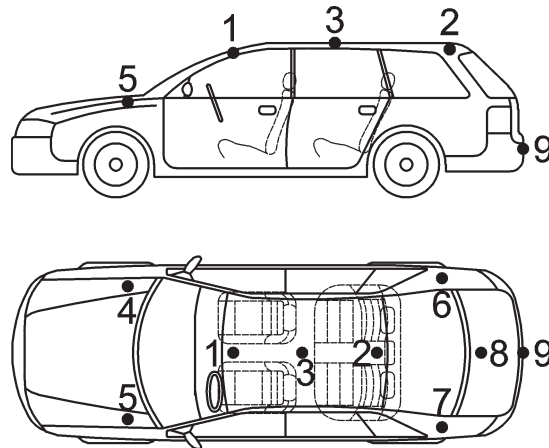

Key

- | | |
|-------------------------|------------------------|
| 1 vehicle roof (front) | 6 fender (rear, right) |
| 2 vehicle roof (rear) | 7 fender (rear, left) |
| 3 vehicle roof (middle) | 8 trunk lid (middle) |
| 4 fender (front, right) | 9 bumper (middle) |
| 5 fender (front, left) | |

Figure 1 — Recommended locations for antennas outside the vehicle

When the vehicle OEM antenna is used, it should be used as it is installed in the vehicle without any change of antenna characteristics (location, VSWR, etc.).

Examples of test set-up for simulated on-board transmitters are shown in [Figure 2](#) (use of test antenna) and [Figure 3](#) (use of vehicle OEM antenna).

NOTE When the vehicle OEM antenna is used for multiple transmitters/receivers frequency, it is advisable not to use a simulated on-board transmitter (with “broadband” amplifier). The amplifier noise level can be sufficient to degrade some vehicle functions, like GPS satellite reception. The validation of such functions (relative to vehicle on-board-transmitter immunity) can only be performed with the vehicle OEM on-board transmitter. In this case, it might be necessary to operate the on-board vehicle transmitter in real conditions. This can be performed by using specific equipment, like a GSM base station simulator (see [7.1.2](#) and [Figure 4](#)).

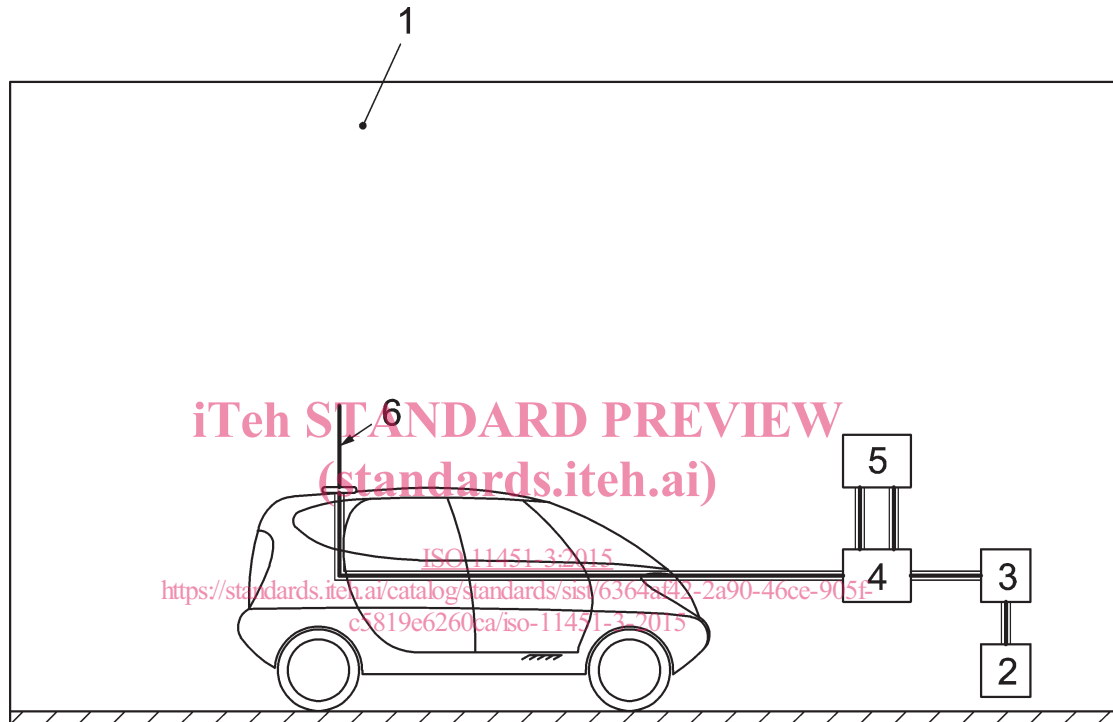

Key

- 1 ALSE
- 2 RF signal generator (can be outside test facility)
- 3 power amplifier (can be outside test facility)
- 4 dual directional coupler (can be outside test facility)
- 5 power meter (can be outside test facility)
- 6 test antenna (positions defined in test plan)

Figure 2 — Example of test set-up for simulated on-board transmitter and test antenna

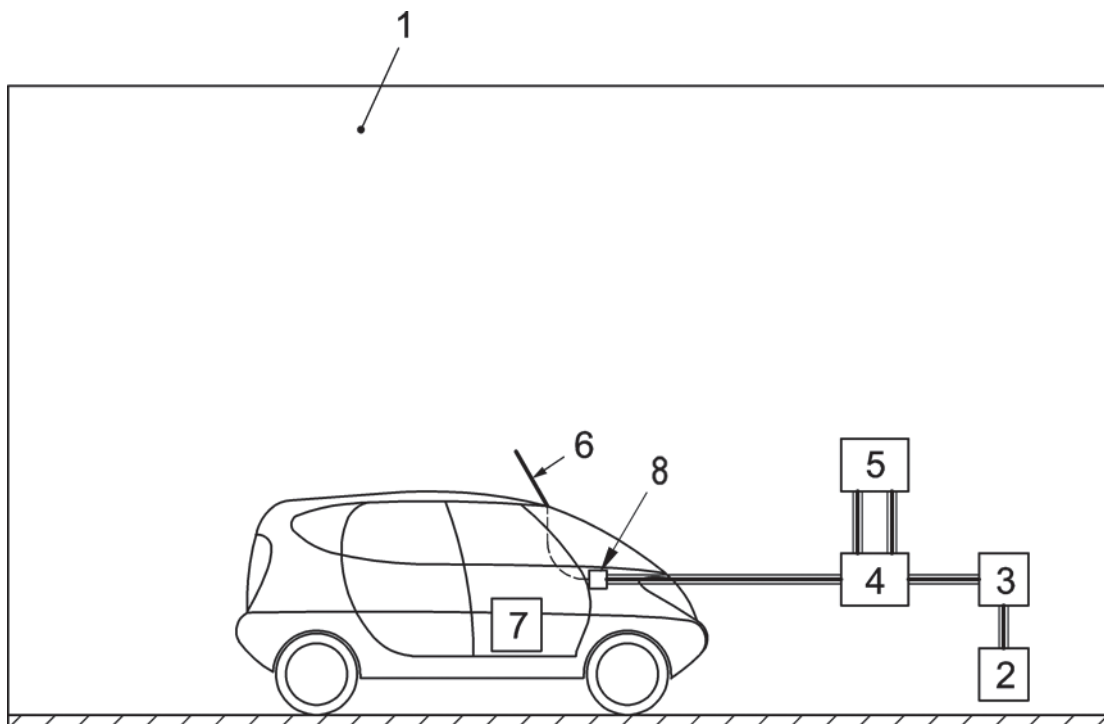

Key

- 1 ALSE
- 2 RF signal generator (can be outside test facility)
- 3 power amplifier (can be outside test facility)
- 4 dual directional coupler (can be outside test facility)
- 5 power meter (can be outside test facility)
- 6 vehicle OEM antenna
- 7 on-board transmitter (disconnected from vehicle antenna)
- 8 vehicle antenna cable connector

iTeh STANDARD PREVIEW
(standards.iteh.ai)

ISO 11451-3:2015
<https://standards.iteh.ai/catalog/standards/sist/6364af42-2a90-46ce-905f-c5819e6260ca/iso-11451-3-2015>

Figure 3 — Example of test set-up for simulated on-board transmitter and vehicle OEM antenna

7.1.2 Commercial on-board transmitters

The vehicle commercial on-board transmitter and OEM antenna should be used as it is installed in the vehicle, without any change of transmitter and antenna characteristics (location, VSWR, etc.).

An example of test set-up for commercial on-board transmitters is shown in [Figure 4](#).

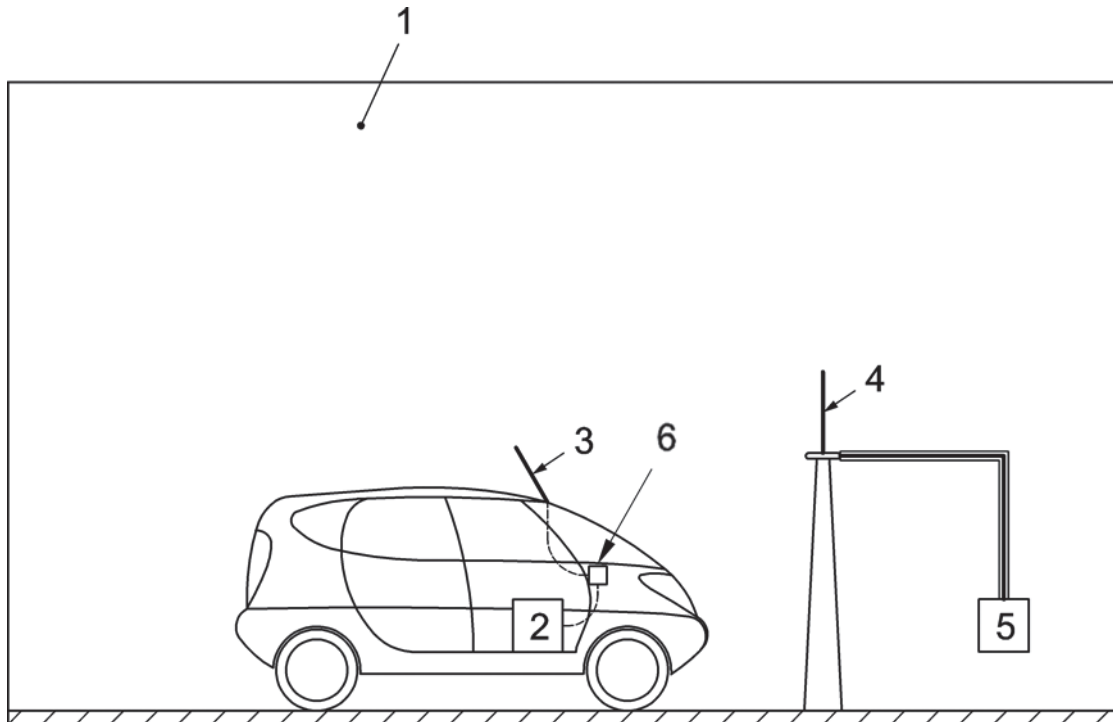
**Key**

- 1 ALSE
- 2 on-board transmitter (connected to vehicle antenna)
- 3 vehicle OEM antenna
- 4 antenna (when necessary)
- 5 base station simulator inside or outside test facility (when necessary)
- 6 vehicle antenna cable connector

Figure 4 — Example of test set-up for commercial on-board transmitter

7.2 Transmitters with antenna inside the vehicle

7.2.1 General

The location(s) of a simulated or commercial portable transmitter in the vehicle shall be defined in the test plan. If no specific location(s) are agreed between the users of this part of ISO 11451, the following location(s) are recommended:

- at the driver's head position (centred on the back of the seat at a height of 0,8 m from the seat cushion, with the seat in medium position), antenna in vertical polarization;
- at the passenger's head position (centred the back of the seat at a height of 0,8 m from the seat cushion, with the seat in medium position), antenna in vertical polarization;
- in specified places where a portable transmitter can be placed, i.e. between front seats, on the vehicle's centre console, storage compartments;
- at the rear passenger's head position (centred on the back of the seat at a height of 0,8 m from the seat cushion, with the seat in medium position), antenna in vertical polarization.

7.2.2 Simulated portable transmitters

An example of test set-up for simulated portable transmitters is shown in [Figure 5](#).

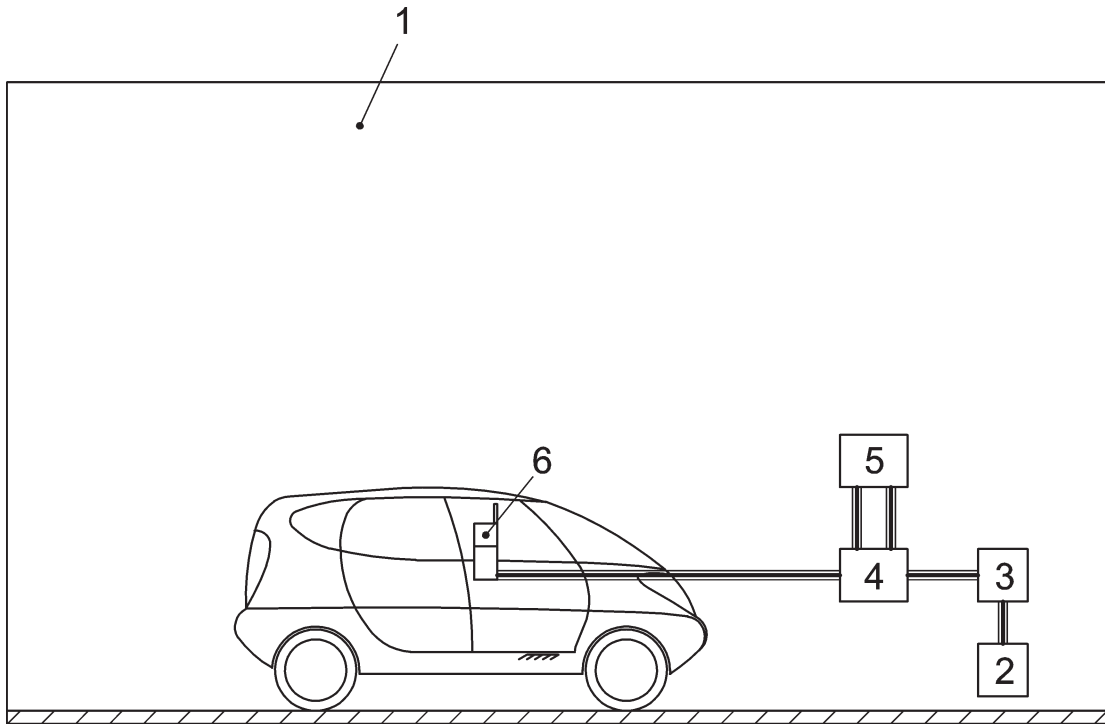

Key

- 1 ALSE
- 2 RF signal generator (can be outside test facility)
- 3 power amplifier (can be outside test facility)
- 4 dual directional coupler (can be outside test facility)
- 5 power meter (can be outside test facility)
- 6 simulated portable transmitter (positions defined in test plan)

iTeh STANDARD PREVIEW
(standards.iteh.ai)

Figure 5 — Example of test set-up for simulated portable transmitters

7.2.3 Commercial portable transmitters

Examples of test set-up for commercial portable transmitters are shown in [Figures 6](#) and [7](#) (use of base station simulator).

NOTE Certain RF systems (e.g. GSM phones) transmit with different RF power levels and frequencies. In such cases, the test might not necessarily be performed at the maximum RF power level. To control output power and frequency, either devices with modified software or base station simulators can be used.

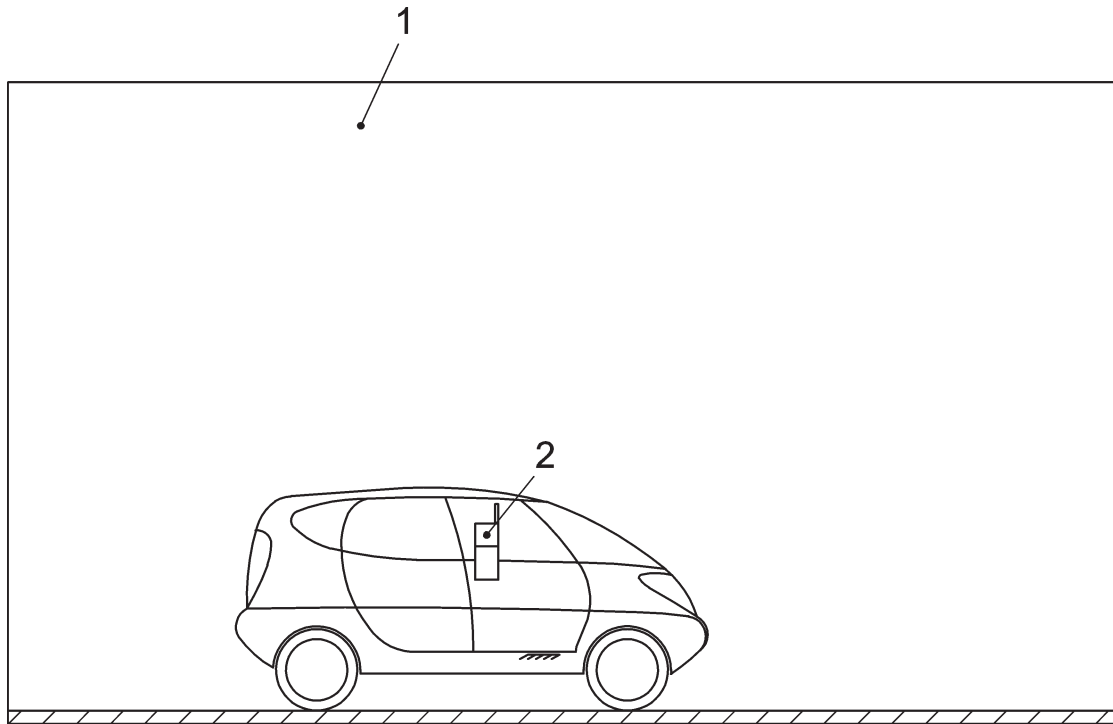
**Key**

- 1 ALSE
- 2 commercial portable transmitter (positions defined in test plan)

iTeh STANDARD PREVIEW
(standards.iteh.ai)

Figure 6 — Example of test set-up for commercial portable transmitters

<https://standards.iteh.ai/catalog/standards/sist/6364af42-2a90-46ce-905f-c5819e6260ca/iso-11451-3-2015>