**Road vehicles — Connection interface
for pyrotechnic devices, two-way and
three-way connections —**

**Part 1:
Pocket interface definition**

iTeh STANDARD PREVIEW
*Véhicules routiers — Interface de raccordement pour dispositifs
pyrotechniques, deux voies et trois voies —
(standards.iteh.ai)
Partie 1: Définition de l'interface du support allumeur*

[ISO 19072-1:2014](https://standards.iteh.ai/catalog/standards/sist/a39351a8-5099-4abf-9b57-7fe8696c4ed9/iso-19072-1-2014)

<https://standards.iteh.ai/catalog/standards/sist/a39351a8-5099-4abf-9b57-7fe8696c4ed9/iso-19072-1-2014>



iTeh STANDARD PREVIEW
(standards.iteh.ai)

ISO 19072-1:2014

<https://standards.iteh.ai/catalog/standards/sist/a39351a8-5099-4abf-9b57-7fe8696c4ed9/iso-19072-1-2014>



COPYRIGHT PROTECTED DOCUMENT

© ISO 2014

All rights reserved. Unless otherwise specified, no part of this publication may be reproduced or utilized otherwise in any form or by any means, electronic or mechanical, including photocopying, or posting on the internet or an intranet, without prior written permission. Permission can be requested from either ISO at the address below or ISO's member body in the country of the requester.

ISO copyright office
Case postale 56 • CH-1211 Geneva 20
Tel. + 41 22 749 01 11
Fax + 41 22 749 09 47
E-mail copyright@iso.org
Web www.iso.org

Published in Switzerland

Contents

	Page
Foreword.....	iv
Introduction.....	v
1 Scope.....	1
2 Normative references.....	1
3 Terms and definitions.....	1
4 Dimensional features — Squib holder interface including male contacts.....	2
5 Material characteristics.....	4
5.1 Material specifications for male contacts.....	4
5.2 Contacts and short circuit areas of the male contacts specifications.....	4
Annex A (normative) Sealed variant.....	5
Annex B (normative) Variant without retainer of the pyrotechnic device/initiator harness connector assembly.....	6
Bibliography.....	7

iTeh STANDARD PREVIEW (standards.iteh.ai)

[ISO 19072-1:2014](https://standards.iteh.ai/catalog/standards/sist/a39351a8-5099-4abf-9b57-7fe8696c4ed9/iso-19072-1-2014)

<https://standards.iteh.ai/catalog/standards/sist/a39351a8-5099-4abf-9b57-7fe8696c4ed9/iso-19072-1-2014>

Foreword

ISO (the International Organization for Standardization) is a worldwide federation of national standards bodies (ISO member bodies). The work of preparing International Standards is normally carried out through ISO technical committees. Each member body interested in a subject for which a technical committee has been established has the right to be represented on that committee. International organizations, governmental and non-governmental, in liaison with ISO, also take part in the work. ISO collaborates closely with the International Electrotechnical Commission (IEC) on all matters of electrotechnical standardization.

The procedures used to develop this document and those intended for its further maintenance are described in the ISO/IEC Directives, Part 1. In particular the different approval criteria needed for the different types of ISO documents should be noted. This document was drafted in accordance with the editorial rules of the ISO/IEC Directives, Part 2 (see www.iso.org/directives).

Attention is drawn to the possibility that some of the elements of this document may be the subject of patent rights. ISO shall not be held responsible for identifying any or all such patent rights. Details of any patent rights identified during the development of the document will be in the Introduction and/or on the ISO list of patent declarations received (see www.iso.org/patents).

Any trade name used in this document is information given for the convenience of users and does not constitute an endorsement.

For an explanation on the meaning of ISO specific terms and expressions related to conformity assessment, as well as information about ISO's adherence to the WTO principles in the Technical Barriers to Trade (TBT) see the following URL: Foreword - Supplementary information

The committee responsible for this document is ISO/TC 22, *Road vehicles*, Subcommittee SC 3, *Electrical and electronic equipment*.

This second edition cancels and replaces the first edition (ISO 19072-1:2007), which has been technically revised.

ISO 19072 consists of the following parts, under the general title *Road vehicles — Connection interface for pyrotechnic devices, two way and three way connections*:

- *Part 1: Pocket interface definition*
- *Part 2: Test methods and general performance requirements*
- *Part 3: Pyrotechnic device and harness connector assembly - type 1*
- *Part 4: Pyrotechnic device and harness connector assembly - type 2*

Introduction

Road vehicles integrate an increasing number of pyrotechnic devices contributing to occupant safety in vehicles (for example, frontal and side air bag, safety belt pretensioner, etc.).

Various pocket definitions currently exist all over the world. This situation appears difficult to manage for the different equipment makers. The goal of this International Standard is to define a common specification.

A sealed option of the pyrotechnic device/initiator harness connector assembly is also defined. See [Annex A](#).

A variant without retainer of the pyrotechnic device/initiator harness connector assembly is also defined. See [Annex B](#).

The International Organization for Standardization (ISO) draws attention to the fact that it is claimed that compliance with this document may involve the use of a patents DE19939407, EP-B-1079474 and US-A-6,402,640.

ISO takes no position concerning the evidence, validity and scope of this patent right.

The holder of this patent right has assured ISO that he/she is willing to negotiate licences either free of charge or under reasonable and non-discriminatory terms and conditions with applicants throughout the world. In this respect, the statement of the holder of this patent right is registered with ISO. Information may be obtained from:

FCI

145, rue Yves Le-Coz

78000 Versailles

France

iTeh STANDARD PREVIEW
(standards.iteh.ai)

[ISO 19072-1:2014](#)

<https://standards.iteh.ai/catalog/standards/sist/a39351a8-5099-4abf-9b57-7fe8696c4ed9/iso-19072-1-2014>

Attention is drawn to the possibility that some of the elements of this document may be the subject of patent rights other than those identified above. ISO shall not be held responsible for identifying any or all such patent rights.

ISO (www.iso.org/patents) maintains an on-line database of patents relevant to its standards. Users are encouraged to consult the database for the most up to date information concerning patents.

iTeh STANDARD PREVIEW
(standards.iteh.ai)

[ISO 19072-1:2014](https://standards.iteh.ai/catalog/standards/sist/a39351a8-5099-4abf-9b57-7fe8696c4ed9/iso-19072-1-2014)

<https://standards.iteh.ai/catalog/standards/sist/a39351a8-5099-4abf-9b57-7fe8696c4ed9/iso-19072-1-2014>

Road vehicles — Connection interface for pyrotechnic devices, two-way and three-way connections —

Part 1: Pocket interface definition

1 Scope

The purpose of this part of ISO 19072 is to define the minimum specification of the pyrotechnic device pocket interface.

2 Normative references

The following documents, in whole or in part, are normatively referenced in this document and are indispensable for its application. For dated references, only the edition cited applies. For undated references, the latest edition of the referenced document (including any amendments) applies.

ASTM B488: *Standard Specification for Electrodeposited Coatings of Gold for Engineering Uses*

ASTM B735: *Standard Test Method for Porosity in Gold Coatings on Metal Substrates by Nitric Acid Vapor*

3 Terms and definitions

ISO 19072-1:2014

For the purposes of this document, the following terms and definitions apply.

3.1

connector

assembly used to connect several conductors together or a single conductor to an appliance

Note 1 to entry: A male (female) connector is a housing containing male (female) contacts and accessory items. A male connector may be permanently fixed to a wiring harness or to an appliance [an electronic control unit (ECU) for example]. A female connector is generally permanently fixed to a wiring harness.

3.2

female contact

contact (including means for cable attachment) designed for electrical engagement on its inner surface, and to accept entry of a male contact, thus forming an electrical connection

[SOURCE: ISO 8092-2:2005, 3.6]

3.3

housing

connector without its contacts

3.4

initiator

part of the pyrotechnical device with two male contacts

3.5

male contact

contact (including means for cable attachment) designed for electrical engagement on its outer surface and to enter a female contact, thus forming an electrical connection

[SOURCE: ISO 8092-2:2005, 3.5]

3.6

pocket

squib holder inner interface including male contacts

3.7

retainer

ring holding an optional shorting clip (shunt) and providing coding and electrical insulation, generally made of plastic

Note 1 to entry: The shorting clip (shunt) may be omitted by decision between manufacturer and supplier.

3.8

shorting clip (shunt)

metallic bar of the retainer providing the electrical connection between two male contacts

3.9

squib holder

part of the pyrotechnic device, holding the initiator and the retainer

iTeh STANDARD PREVIEW

4 Dimensional features — Squib holder interface including male contacts

(standards.iteh.ai)

The contact and short-circuit areas when male and female connectors are mated shall comply with [Figure 1](#).

[ISO 19072-1:2014](#)

<https://standards.iteh.ai/catalog/standards/sist/a39351a8-5099-4abf-9b57-7fe8696c4ed9/iso-19072-1-2014>

Dimensions in millimetres

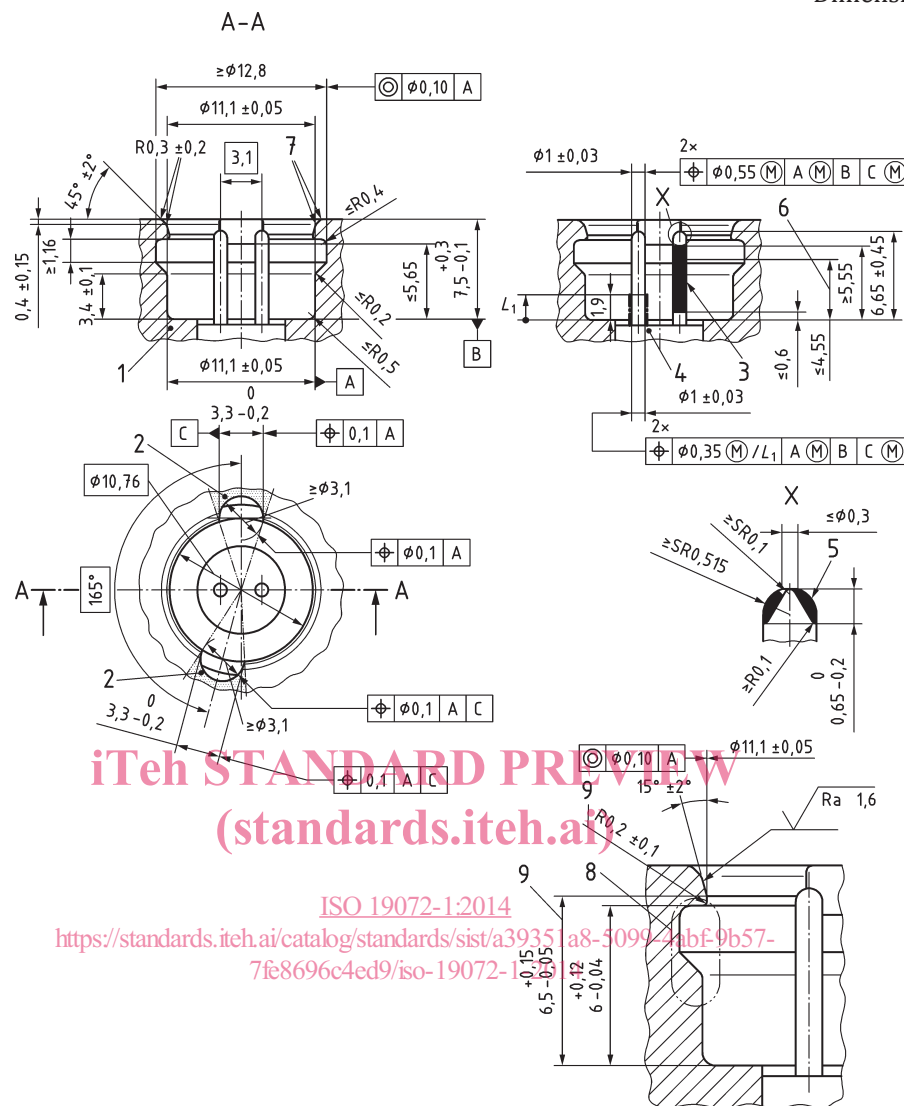

iTeh STANDARD PREVIEW
(standards.itech.ai)

ISO 19072-1:2014
<https://standards.itech.ai/catalog/standards/sist/a39351a8-5099-41bf-9b57-7fe8696c4ed9/iso-19072-1>

Key

- 1 squib holder
- 2 area in which any shape is acceptable
- 3 minimum plating contact and short-circuit areas according to 5.2; plating shall extend to the tip of the pin
- 4 any shape accepted; surface of initiator shall be flush with or below datum B but shall meet the connector / retainer function requirement
- 5 any convex or straight shape inside shaded area accepted at top of pin shall be smooth and burr free
- 6 maximum contact point; the female contact shall guarantee a minimum overlap of 1 mm in the contact area
- 7 rounded and burr free
- 8 undercut geometry required to hold the connector and retainer inside the squib holder; the undercut surface does not need to be a continuous 360° surface and shall meet the specified connector and retainer retention requirements and dimensions regardless of material
- 9 for existing tools to produce plastic pockets, the following values are also allowed: $R\ 0,15_{-0,1}^0 - H\ 6,35_{-0,05}^0$

NOTE Datum C depending on the style of the polarization area (hole or slot).

Figure 1 — Squib holder interface with male contacts