



SLOVENSKI STANDARD
oSIST prEN ISO 8437-3:2016
01-junij-2016

Snežne freze - Varnostne zahteve in preskusni postopki - 3. del: Snežne freze, na katerih se sedi (ISO/DIS 8437-3:2016)

Snow throwers - Safety requirements and test procedures - Part 3: Ride-on snow throwers (ISO/DIS 8437-3:2016)

Schneefräsen - Sicherheitsanforderungen und Prüfverfahren - Teil 3: Schneefräsen mit Fahrersitz (ISO/DIS 8437-3:2016)

Chasse-neige - Exigences de sécurité et essais - Partie 3: Chasse-neige à conducteur porté (ISO/DIS 8437-3:2016)

ITEH STANDARD PREVIEW
(standards.iteh.ai)
[kSIST FprEN ISO 8437-3:2018](https://standards.iteh.ai/catalog/standards/sist/4a8a6b15-c8b5-4d92-b0bb-763ff0445c35/ksist-pr-en-iso-8437-3-2016)
<https://standards.iteh.ai/catalog/standards/sist/4a8a6b15-c8b5-4d92-b0bb-763ff0445c35/ksist-pr-en-iso-8437-3-2016>

Ta slovenski standard je istoveten z: prEN ISO 8437-3

ICS:

43.160 Vozila za posebne namene Special purpose vehicles

oSIST prEN ISO 8437-3:2016

en,fr,de

iTeh STANDARD PREVIEW
(standards.iteh.ai)

[kSIST FprEN ISO 8437-3:2018](https://standards.iteh.ai/catalog/standards/sist/4a8a6b15-c8b5-4d92-b0bb-763ff0445c35/ksist-fpren-iso-8437-3-2018)

<https://standards.iteh.ai/catalog/standards/sist/4a8a6b15-c8b5-4d92-b0bb-763ff0445c35/ksist-fpren-iso-8437-3-2018>

DRAFT INTERNATIONAL STANDARD

ISO/DIS 8437-3

ISO/TC 23/SC 13

Secretariat: ANSI

Voting begins on:
2016-04-07Voting terminates on:
2016-07-06

Snow throwers — Safety requirements and test procedures —

Part 3: Ride-on snow throwers

*Chasse-neige — Exigences de sécurité et essais —**Partie 3: Chasse-neige à conducteur assis*

ICS: 43.160

iTeh STANDARD PREVIEW
(standards.iteh.ai)

[kSIST FprEN ISO 8437-3:2018](https://standards.iteh.ai/catalog/standards/sist/4a8a6b15-c8b5-4d92-b0bb-763ff0445c35/ksist-fpren-iso-8437-3-2018)<https://standards.iteh.ai/catalog/standards/sist/4a8a6b15-c8b5-4d92-b0bb-763ff0445c35/ksist-fpren-iso-8437-3-2018>

THIS DOCUMENT IS A DRAFT CIRCULATED FOR COMMENT AND APPROVAL. IT IS THEREFORE SUBJECT TO CHANGE AND MAY NOT BE REFERRED TO AS AN INTERNATIONAL STANDARD UNTIL PUBLISHED AS SUCH.

IN ADDITION TO THEIR EVALUATION AS BEING ACCEPTABLE FOR INDUSTRIAL, TECHNOLOGICAL, COMMERCIAL AND USER PURPOSES, DRAFT INTERNATIONAL STANDARDS MAY ON OCCASION HAVE TO BE CONSIDERED IN THE LIGHT OF THEIR POTENTIAL TO BECOME STANDARDS TO WHICH REFERENCE MAY BE MADE IN NATIONAL REGULATIONS.

RECIPIENTS OF THIS DRAFT ARE INVITED TO SUBMIT, WITH THEIR COMMENTS, NOTIFICATION OF ANY RELEVANT PATENT RIGHTS OF WHICH THEY ARE AWARE AND TO PROVIDE SUPPORTING DOCUMENTATION.

To expedite distribution, this document is circulated as received from the committee secretariat. ISO Central Secretariat work of editing and text composition will be undertaken at publication stage.



Reference number
ISO/DIS 8437-3:2016(E)

iTeh STANDARD PREVIEW (standards.iteh.ai)

[kSIST FprEN ISO 8437-3:2018](https://standards.iteh.ai/catalog/standards/sist/4a8a6b15-c8b5-4d92-b0bb-763ff0445c35/ksist-fpren-iso-8437-3-2018)

<https://standards.iteh.ai/catalog/standards/sist/4a8a6b15-c8b5-4d92-b0bb-763ff0445c35/ksist-fpren-iso-8437-3-2018>



COPYRIGHT PROTECTED DOCUMENT

© ISO 2016, Published in Switzerland

All rights reserved. Unless otherwise specified, no part of this publication may be reproduced or utilized otherwise in any form or by any means, electronic or mechanical, including photocopying, or posting on the internet or an intranet, without prior written permission. Permission can be requested from either ISO at the address below or ISO's member body in the country of the requester.

ISO copyright office
Ch. de Blandonnet 8 • CP 401
CH-1214 Vernier, Geneva, Switzerland
Tel. +41 22 749 01 11
Fax +41 22 749 09 47
copyright@iso.org
www.iso.org

Contents

Foreword.....	3
Introduction	3
1 Scope.....	5
2 Normative references.....	5
3 Terms and definitions	6
4 Snow thrower safety requirements and test procedures	6
Annex A (normative)	22
A.1 Instruction Handbook	22
A.2 Markings.....	23
A.3 Warnings.....	24
A.4 Label durability requirements.....	24
Bibliography	24

<https://standards.iteh.ai/catalog/standards/sist/4a8a6b15-c8b5-4d92-b0bb-763ff0445c35/ksist-fpren-iso-8437-3-2018>

Foreword

ISO (the International Organization for Standardization) is a worldwide federation of national standards bodies (ISO member bodies). The work of preparing International Standards is normally carried out through ISO technical committees. Each member body interested in a subject for which a technical committee has been established has the right to be represented on that committee. International organizations, governmental and non-governmental, in liaison with ISO, also take part in the work. ISO collaborates closely with the International Electrotechnical Commission (IEC) on all matters of electrotechnical standardization.

The procedures used to develop this document and those intended for its further maintenance are described in the ISO/IEC Directives, Part 1. In particular the different approval criteria needed for the different types of ISO documents should be noted. This document was drafted in accordance with the editorial rules of the ISO/IEC Directives, Part 2. www.iso.org/directives

Attention is drawn to the possibility that some of the elements of this document may be the subject of patent rights. ISO shall not be held responsible for identifying any or all such patent rights. Details of any patent rights identified during the development of the document will be in the Introduction and/or on the ISO list of patent declarations received. www.iso.org/patents

Any trade name used in this document is information given for the convenience of users and does not constitute an endorsement.

For an explanation on the meaning of ISO specific terms and expressions related to conformity assessment, as well as information about ISO's adherence to the WTO principles in the Technical Barriers to Trade (TBT) see the following URL: [Foreword - Supplementary information](http://www.iso.org/foreword)

ISO 8437 was prepared by Technical Committee ISO/TC 23, *Tractors and Machinery for Agriculture and Forestry*, Subcommittee SC 13, *Lawn and Garden Equipment*.

ISO 8437 consists of the following parts under the general title Snow thrower – Safety requirements and test procedures:

Part 1: Terminology and common tests

Part 2: Pedestrian controlled snow throwers

Part 3: Ride-on snow throwers

Part 4: National and regional provisions

Introduction

The structure of safety standards in the field of machinery is as follows:

a) Type-A standards (basic standards) give basic concepts, principles for design, and general aspects that can be applied to machinery;

ISO/DIS 8437-3:2016(E)

b) Type-B standards (generic safety standards) deal with one or more safety aspects or safeguards that can be used across a wide range of machinery:

- type-B1 standards on particular safety aspects (e.g. safety distances, surface temperature, noise);
- type-B2 standards on safeguards (e.g. two-handed controls, interlocking devices, pressure sensitive devices, guards);

c) Type-C standards (machinery safety standards) deal with detailed safety requirements for a particular machine or group of machines.

This international standard is a type-C standard as stated in ISO 12100.

When provisions of this type-C standard are different from those which are stated in type-A or type-B standards, the provisions of this type-C standard shall take precedence over the provisions of the other standards for machines that have been designed and built according to the provisions of this type-C standard.

iTeh STANDARD PREVIEW (standards.iteh.ai)

[kSIST FprEN ISO 8437-3:2018](https://standards.iteh.ai/catalog/standards/sist/4a8a6b15-c8b5-4d92-b0bb-763ff0445c35/ksist-fpren-iso-8437-3-2018)

<https://standards.iteh.ai/catalog/standards/sist/4a8a6b15-c8b5-4d92-b0bb-763ff0445c35/ksist-fpren-iso-8437-3-2018>

Snow throwers – Safety requirements and test procedures – Part 3: Ride-on snow throwers

1 Scope

This part of ISO 8437 defines terms and definitions and common test methods applicable to combustion engine powered ride-on snow throwers.

This standard deals with significant hazards, hazardous situations and events relevant to snow throwers used as intended and under the conditions reasonably foreseen by the manufacturer.

This international standard does not apply to:

- electrically powered and battery powered snow throwers
- hand-held snow throwers
- airport or highway snow removal machines and equipment
- machines intended for use in potentially explosive atmospheres

This international standard does not deal with hazards related to:

- battery circuits exceeding 42 V;
- mains connected starting motor
- magneto grounding circuits;
- working environment;
- electromagnetic compatibility

This international standard is not applicable to machines which are manufactured before the date of its publication.

[kSIST FprEN ISO 8437-3:2018](https://standards.iteh.ai/catalog/standards/sist/4a8a6b15-c8b5-4d92-b0bb-763ff0445c35/ksist-fpren-iso-8437-3-2018)

<https://standards.iteh.ai/catalog/standards/sist/4a8a6b15-c8b5-4d92-b0bb-763ff0445c35/ksist-fpren-iso-8437-3-2018>

2 Normative references

The following documents, in whole or in part, are normatively referenced in this document and are indispensable for its application. For dated references, only the edition cited applies. For undated references, the latest edition of the referenced document (including any amendments) applies.

ISO 3767 – 1	1998	<i>Tractors, machinery for agriculture and forestry, powered lawn and garden equipment -- Symbols for operator controls and other displays -- Part 1: Common symbols</i>
ISO 3864-1	2011	<i>Graphical symbols -- Safety colours and safety signs -- Part 1: Design principles for safety signs in workplaces and public areas</i>
ISO 5673 - 1	2005	<i>Agricultural tractors and machinery -- Power take-off drive shafts and power-input connection -- Part 1: General manufacturing and safety requirements</i>
ISO 8437 - 1	201x	<i>Snow throwers – Safety requirements and test procedures - Part 1: Terminology and common tests</i>
ISO 8437 - 2	201x	<i>Snow throwers – Safety requirements and test procedures – Part 2: Pedestrian controlled snow throwers</i>

ISO/DIS 8437-3:2016(E)

ISO 8437 - 4	201x	<i>Snow throwers – Safety requirements and test procedures - Part 4: Information on national and regional provisions</i>
ISO 12100	2010	<i>Safety of machinery – General principles of design – risk assessment and risk reduction</i>
ISO 13857	2008	<i>Safety of machinery -- Safety distances to prevent hazard zones being reached by upper and lower limbs</i>

3 Terms and definitions

For the purposes of this document, the terms and definitions in ISO 12100 and ISO 8437 -1 apply.

4 Snow thrower safety requirements and test procedures**4.1 General**

The machines shall comply with the safety requirements and/or protective measures of this clause. In addition, the machine shall be designed according to the principles of ISO 12100 for hazards relevant but not significant, which are not dealt with by this document (e.g. sharp edges on the outside of the machine).

Snow throwers shall also be marked according to A.2 and carry warnings according to A.3.

The instruction handbook to be provided with the snow thrower shall comply with A.1.

4.2 Controls

iTeh STANDARD PREVIEW
(standards.iteh.ai)
<https://standards.iteh.ai/catalog/standards/sist/4a8a6b15-c8b5-4d92-b0bb-763ff0445c35/ksist-fpren-iso-8437-3-2018>

4.2.1 General

Except as indicated in the following list operator controls shall be located within, and have a range of movement which remains within, the operator control position given in Figure 2:

- engine controls
- snow discharge chute and deflector control(s)
- manual lift.

The controls shall be designed such that they can be operated by an operator with and without artic mittens see Figure 1.

No controls shall be in any hazard zone (see Figure 2).

Pedals shall have a slip-resistant surface or other means of minimizing the possibility of the operator's foot slipping off the pedals and be easy to clean.

Controls, whose purpose is not obvious to the user, shall have the function, direction and/or method of operation clearly identified by a durable label or mark.

Detailed instructions on the operation of all controls shall be provided in an instruction handbook.

Compliance shall be checked by inspection.

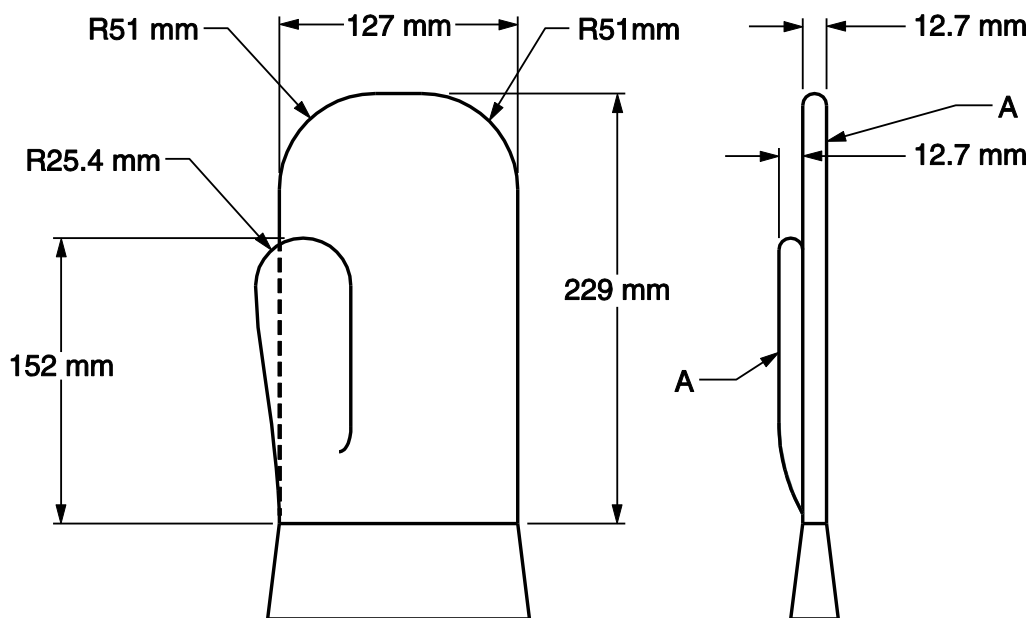

Key

A Pressed Flat

Notes

- 1 All dimensions approximate, without hand in glove
- 2 Material – Buckskin outer shell with knit liner

iTeh STANDARD PREVIEW
(standards.iteh.ai)

[kSIST FprEN ISO 8437-3:2018](https://standards.iteh.ai/catalog/standards/sist/4a8a6b15-c8b5-4d92-b0bb-763ff0445c35/ksist-fpren-iso-8437-3-2018)

<https://standards.iteh.ai/catalog/standards/sist/4a8a6b15-c8b5-4d92-b0bb-763ff0445c35/ksist-fpren-iso-8437-3-2018>

Figure 1 – Arctic mitten

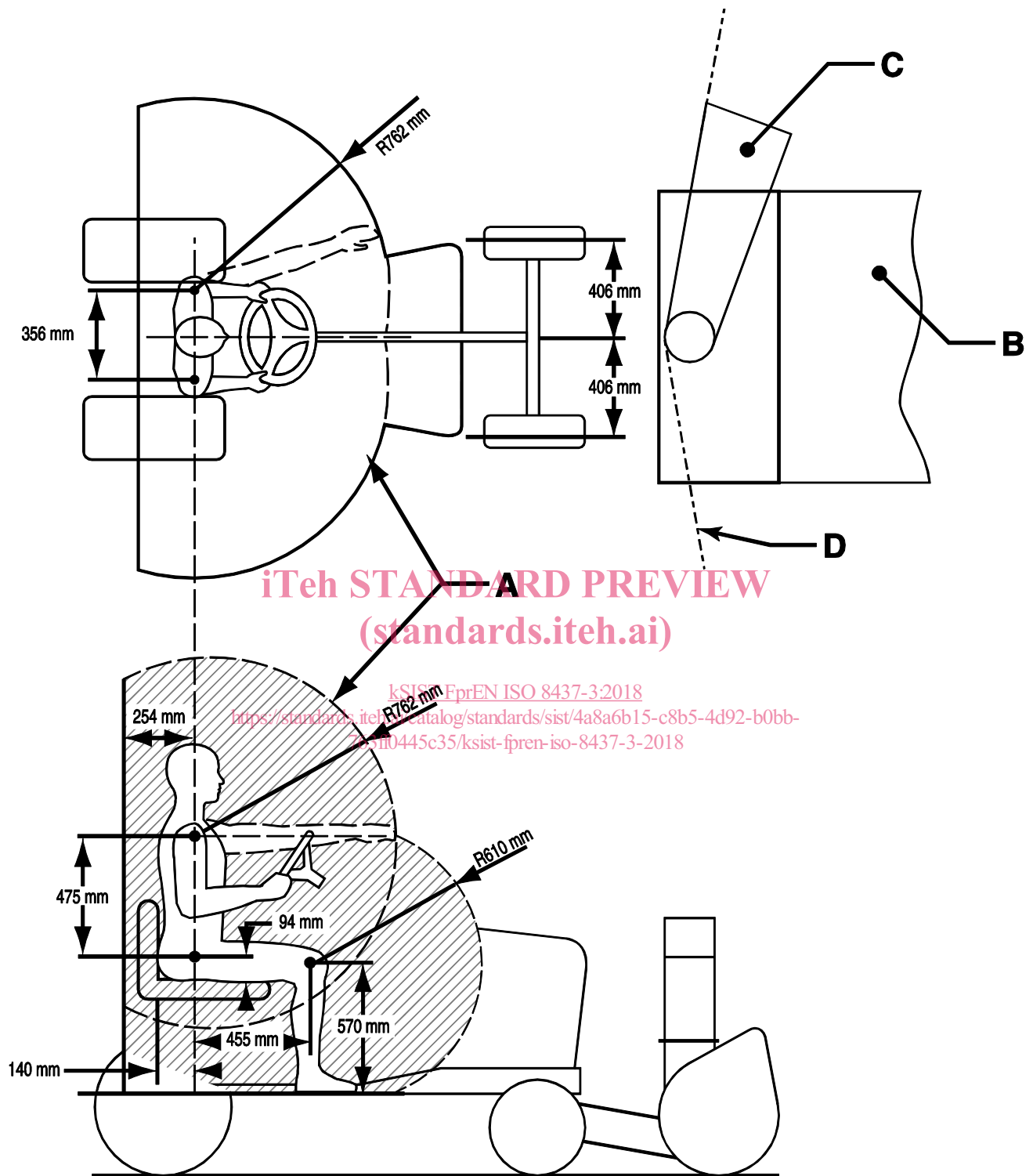

iTeh STANDARD PREVIEW
(standards.iteh.ai)

ksSIST prEN ISO 8437-3:2018
<https://standards.iteh.ai/catalog/standards/sist/4a8a6b15-c8b5-4d92-b0bb-23510445c35/ksist-pr-en-iso-8437-3-2018>

Key

- A Operator position
- B Collector hazard zone
- C Discharge hazard zone
- D Discharge limit