



Designation: ~~C 1019-07~~ Designation: C 1019 - 08

## Standard Test Method for Sampling and Testing Grout<sup>1</sup>

This standard is issued under the fixed designation C 1019; the number immediately following the designation indicates the year of original adoption or, in the case of revision, the year of last revision. A number in parentheses indicates the year of last reapproval. A superscript epsilon ( $\epsilon$ ) indicates an editorial change since the last revision or reapproval.

*This standard has been approved for use by agencies of the Department of Defense.*

### 1. Scope\*

1.1 This test method covers procedures for both field and laboratory sampling and compression testing of grout used in masonry construction. Grout for masonry is specified under Specification C 476.

NOTE 1—The testing agency performing this test method should be evaluated in accordance with Practice C 1093.

1.2 The values stated in inch-pound units are to be regarded as the standard.

1.3 *This standard does not purport to address all of the safety concerns, if any, associated with its use. It is the responsibility of the user of this standard to establish appropriate safety and health practices and determine the applicability of regulatory limitations prior to use.*

### 2. Referenced Documents

2.1 *ASTM Standards:*<sup>2</sup>

C 39/C 39M Test Method for Compressive Strength of Cylindrical Concrete Specimens

C 143/C 143M Test Method for Slump of Hydraulic-Cement Concrete

C 476 Specification for Grout for Masonry

C 511 Specification for Mixing Rooms, Moist Cabinets, Moist Rooms, and Water Storage Tanks Used in the Testing of Hydraulic Cements and Concretes

C 617 Practice for Capping Cylindrical Concrete Specimens

C 1064/C 1064M Test Method for Temperature of Freshly Mixed Hydraulic-Cement Concrete

C 1093 Practice for Accreditation of Testing Agencies for Masonry

C 1611/C 1611M Test Method for Slump Flow of Self-Consolidating Concrete

### 3. Significance and Use

3.1 Grout used in masonry is a fluid mixture of cementitious materials and aggregate with a high water content for ease of placement.

3.1.1 During construction, grout is placed within or between absorptive masonry units. Excess water must be removed from grout specimens in order to provide compressive strength test results more nearly indicative of the grout strength in the wall. In this test method, molds are made from masonry units having the same absorption and moisture content characteristics as those being used in the construction.

3.2 This test method is used to either help select grout proportions by comparing test values or as a quality control test for uniformity of grout preparation during construction.

3.3 The physical exposure condition and curing of the grout are not exactly reproduced, but this test method does subject the grout specimens to absorption conditions similar to those experienced by grout in the wall.

NOTE 2—Test results of grout specimens taken from a wall should not be compared to test results obtained with this test method.

### 4. Apparatus

4.1 *Maximum-Minimum Thermometer*.

4.2 *Straightedge*, a steel straightedge not less than 6 in. (152.4 mm) long and not less than 1/16 in. (1.6 mm) in thickness.

<sup>1</sup> This test method is under the jurisdiction of ASTM Committee C12 on Mortars and Grouts for Unit Masonry and is the direct responsibility of Subcommittee C12.02 on Research and Methods of Test.

Current edition approved July 15, 2007. Published July 2007. Originally approved in 1984. Last previous edition approved in 2005 as C 1019-05.

Current edition approved Feb. 1, 2008. Published March 2008. Originally approved in 1984. Last previous edition approved in 2007 as C 1019-07.

<sup>2</sup> For referenced ASTM standards, visit the ASTM website, [www.astm.org](http://www.astm.org), or contact ASTM Customer Service at [service@astm.org](mailto:service@astm.org). For *Annual Book of ASTM Standards* volume information, refer to the standard's Document Summary page on the ASTM website.

\*A Summary of Changes section appears at the end of this standard.

4.3 *Tamping Rod*, a nonabsorbent rod, either round or square in cross section nominally 5/8 in. (15.9 mm) in dimension with ends rounded to hemispherical tips of the same diameter. The rod shall be a minimum length of 12 in. (304.8 mm).

4.4 *Nonabsorbent Blocks and Spacers*, nonabsorbent, rigid squares and rectangles with side dimensions so as to achieve the desired grout specimen side dimensions and of sufficient quantity or thickness to yield the desired grout specimen height, as shown in Fig. 1, Fig. 2, and Fig. 3.

NOTE 3—Nonabsorbent blocks may be of plastic, wood, or other nonabsorbent material. Certain species of wood contain sugars which cause retardation of cement. In order to prevent this from occurring, new wooden blocks shall be soaked in limewater for 24 h, sealed with varnish or wax, or covered with an impermeable material prior to use.

4.5 *Panels and plates*, pieces of 3/4 in. (19 mm) plywood with dimensions as needed to contain units and grout specimens. Soak in limewater for 24 h, seal with varnish or wax, or cover with an impermeable material prior to use. A nonabsorbant material of equivalent stiffness to the plywood is permitted.

**PROCEDURES**

**5. Test Specimens**

5.1 Each grout specimen shall have a square cross-section, 3 in. (76 mm) or larger on the sides and twice as high as its width. Dimensional tolerances shall be within 5 % of the width selected.

5.2 Test at least three specimens at each age specified.

NOTE 4—Frequency of sampling and age of test is to be determined by the specifier of this test method and is usually found in the construction documents.

**6. Mold Construction**

6.1 Select a level location where the molds remain undisturbed for up to 48 h.

NOTE 5—The location of specimen construction should be protected and as free from perceptible vibration as possible.

6.2 The construction of the mold shall simulate the in-situ construction. If the grout is placed between two different types of masonry units, both types shall be used to construct the mold.

6.3 Form a space with a square cross-section, 3 in. (76 mm) or larger on each side and twice as high as its width, by stacking masonry units of the same type and moisture condition as those being used in the construction. The surface of the unit in contact with the grout specimen shall not have been previously used to mold specimens. Place nonabsorbent blocks, cut to proper size and of the proper thickness or quantity, at the bottom of the space to achieve the necessary height of specimen. Tolerance on space and specimen dimensions shall be within 5 % of the specimen width. See Fig. 1, Fig. 2, and Fig. 3 and accompanying notes.

NOTE 6—Other methods of obtaining grout specimens and specimens of different geometry have been employed in grout testing, but are not described in this test method. Other methods used to obtain grout specimens include: drilling grout-filled cores of regular units; filling cores of masonry units specifically manufactured to provide grout specimens; filling compartments in slotted corrugated cardboard boxes specifically manufactured to provide grout specimens; and forming specimens from different sized masonry units of the same or similar material.

Since test results vary with methods of forming and specimen geometry, comparative test results between the specimen described in this test method and the proposed specimen should be required and confined to a single specimen shape and method of forming.

~~6.4 Line the masonry surfaces that will be in contact with the grout specimen with a thin, permeable material to prevent bond to the masonry units.~~

6.4 Line the masonry surfaces that will be in contact with the grout specimen with a thin, permeable material to prevent bond to the masonry units. New lining material shall be used for each specimen.

NOTE 7—The lining, such as paper towel, is used to aid in stripping the grout specimen from the mold. Proper installation of the lining prevents irregularly sized specimens and varying test results.

6.5 Brace units to prevent displacement during grouting and curing.

**7. Sampling Grout**

7.1 *Size of Sample*— Grout samples to be used for slump and compressive strength tests shall be a minimum of 1/2 ft<sup>3</sup> (0.014 m<sup>3</sup>).

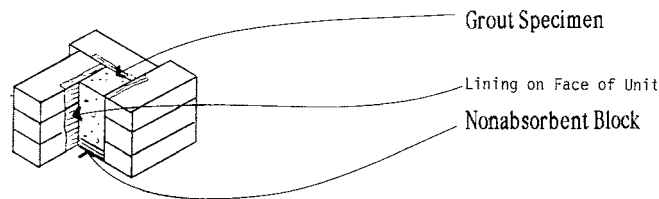

NOTE—Front masonry unit stack not shown to allow view of specimen.  
**FIG. 1 Grout Mold (Units 6 in. (152.4 mm) or Less in Height, 2 1/4 in. (57.2 mm) High Brick Shown)**

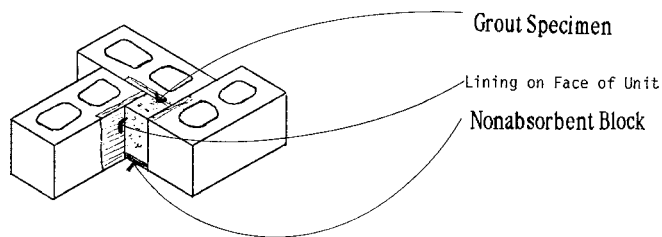

NOTE—Front masonry unit not shown to allow view of specimen.  
**FIG. 2 Grout Mold (Units Greater than 6 in. (152.4 mm) High, 8 in. (203.2 mm) High Concrete Masonry Unit Shown)**

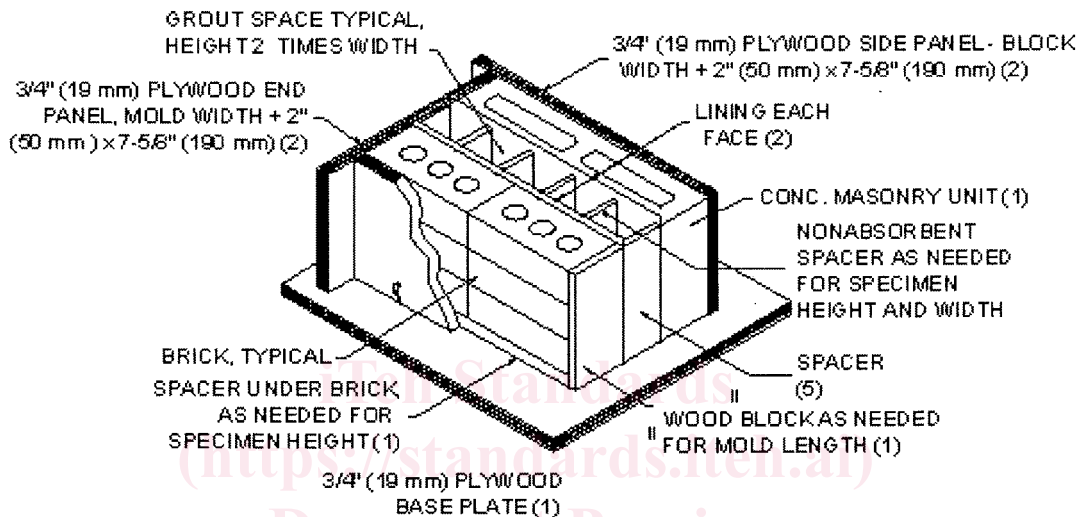

**FIG. 3 Grout Mold with Brick and Concrete Masonry Units**

7.2 *Procedure*—The procedures used in sampling shall include the use of precautions that will assist in obtaining samples that are representative of the nature and condition of the grout. After the final slump adjustment has been made, sample grout as the grout is being placed.

7.2.1 *Field Sampling*—Collect two or more portions taken at regularly spaced intervals during the discharge of the middle portion of the batch. The elapsed time between obtaining the first and final portions of the sample shall be not more than 15 min.

7.2.2 *Laboratory Sampling*—The entire mixed batch of grout is the sample.

NOTE 8—The field technician sampling, making, and curing specimens for acceptance testing should be certified (American Concrete Institute Field Testing Technician—Grade I, National Concrete Masonry Association Masonry Testing Technician, or equivalent). Equivalent certification programs should include both written and performance examinations.

7.3 *Transport the grout sample to the mold location. Protect the sample from the sun, wind, and other sources of rapid evaporation and from contamination. Remix the sample with a shovel or trowel to ensure uniformity.*

7.3 *Place the grout sample in a non-absorptive container and cover the top to protect the sample from the sun, wind, and any other sources of rapid evaporation and from contamination. Transport the grout sample to the mold location. Remix the sample with a shovel or trowel to ensure uniformity prior to filling molds. Keep remaining grout sample protected until used to fill any depression in the sample due to initial water loss.*

## 8. Temperature and Slump Test

8.1 Measure and record the temperature of the grout sample in accordance with Test Method C 1064/C 1064M.

8.2 Begin filling the slump cone within 5 min of obtaining the final portion of the sample.

8.3 For all grout except self-consolidating grout, measure and record the slump in accordance with the requirements of Test Method C 143/C 143M.

8.4 For self-consolidating grout, measure and record the slump flow in accordance with the requirements of Test Method C 1611/C 1611M and visual stability index (VSI) in accordance with the requirements of Test Method C 1611/C 1611M, Appendix X1.

## 9. Compressive Test Specimen

9.1 If grout from the slump or slump flow test is used for the compressive test specimens, remix the sample. Begin filling the