



Designation: D 4851 – 97

Standard Test Methods for Coated and Laminated Fabrics for Architectural Use¹

This standard is issued under the fixed designation D 4851; the number immediately following the designation indicates the year of original adoption or, in the case of revision, the year of last revision. A number in parentheses indicates the year of last reapproval. A superscript epsilon (ϵ) indicates an editorial change since the last revision or reapproval.

1. Scope

1.1 These test methods cover the testing of coated and laminated fabrics made primarily for use in fabric roof systems. These coated and laminated fabrics are generally in either an air supported or tension supported construction of fabric roof systems.

1.2 These methods can be used for most fiber-based, coated and laminated architectural fabrics.

1.3 This standard includes the following sections that provide test procedures for coated and laminated architectural fabrics:

	Section
Fabric Count	8
Mass per Unit Area	9
Fabric Thickness	10
Fabric Width	11
Fabric Length	12
Fabric Bow	13
Adhesion of Coating to Fabric	14
Uniaxial Elongation Under Static Load	15
Fabric Breaking Force	16
Breaking Strength After Crease Fold	17
Elongation at Break	18
Fabric Trapezoid Tear Force	19
Resistance to Accelerated Weathering	20
Solar Optical Properties	21
Fabric Flame Resistance	22
Noise Reduction Coefficient	23

1.4 These test methods include only testing procedures and do not include specifications or tolerances. They are intended as a guide for specifications. Any of these methods may be used in material specifications to evaluate requirements for a specific end use as related to a particular job.

1.5 The values stated in either SI or inch-pound units are to be regarded separately as the standard. Within the text, the inch-pound units are shown in parentheses. The values stated in each system are not exact equivalents; therefore, each system shall be used independently of the other.

1.6 *This standard does not purport to address all of the safety concerns, if any, associated with its use. It is the responsibility of the user of this standard to establish appro-*

priate safety and health practices and determine the applicability of regulatory limitations prior to use.

2. Referenced Documents

2.1 ASTM Standards:

- C 423 Test Method for Sound Absorption and Sound Absorption Coefficients by the Reverberation Room Method²
- D 123 Terminology Relating to Textiles³
- D 751 Test Methods for Coated Fabrics⁴
- D 1003 Test Method for Haze and Luminous Transmittance of Transparent Plastics⁵
- D 1494 Test Method for Diffuse Light Transmission Factor of Reinforced Plastics Panels⁶
- D 1776 Practice for Conditioning Textiles for Testing³
- D 1777 Method of Measuring Thickness of Textile Materials³
- D 2904 Practice for Interlaboratory Testing of a Textile Test Method that Produces Normally Distributed Data³
- D 2906 Practice for Statements on Precision and Bias for Textiles³
- D 3773 Test Methods for Length of Woven Fabric⁷
- D 3774 Test Methods for Width of Woven Fabric⁷
- D 3775 Test Method for Fabric Count of Woven Fabric⁷
- D 3776 Test Methods for Mass Per Unit Area (Weight) of Woven Fabric⁷
- D 3882 Test Method for Bow and Skewness in Woven and Knitted Fabrics⁷
- D 4848 Terminology of Force, Deformation and Related Properties of Textiles⁷
- D 5035 Test Method for Breaking Strength and Elongation of Textile Fabrics (Grab Test)⁷
- D 5587 Test Method for Tearing Strength of Fabrics by the Trapezoid Procedure⁷
- E 84 Test Method for Surface Burning Characteristics of Building Materials⁸
- E 108 Test Methods for Fire Tests of Roof Coverings⁸

¹ These test methods are under the jurisdiction of ASTM Committee D-13 on Textiles and are the direct responsibility of Subcommittee D13.59 on Fabric Test Methods, General.

Current edition approved January 10, 1997. Published March 1997. Originally published as D 4851 – 88.

² Annual Book of ASTM Standards, Vol 04.06.

³ Annual Book of ASTM Standards, Vol 07.01.

⁴ Annual Book of ASTM Standards, Vol 09.02.

⁵ Annual Book of ASTM Standards, Vol 08.01.

⁶ Annual Book of ASTM Standards, Vol 07.02.

⁷ Annual Book of ASTM Standards, Vol 04.07.

⁸ Annual Book of ASTM Standards, Vol 12.02.

E 136 Test Method for Behavior of Materials in a Vertical Tube Furnace at 750°C⁸

E 424 Test Methods for Solar Energy Transmittance and Reflectance (Terrestrial) of Sheet Material⁸

G 23 Practice for Operating Light-Exposure Apparatus (Carbon-Arc Type) With and Without Water for Exposure of Nonmetallic Materials⁹

G 26 Practice for Operating Light-Exposure Apparatus (Xenon-Arc Type) With and Without Water for Exposure of Nonmetallic Materials⁹

G 53 Practice for Operating Light- and Water-Exposure Apparatus (Fluorescent UV-Condensation Type) for Exposure of Nonmetallic Materials⁹

2.2 *Adjunct:*

TEX-PAC¹⁰

2.3 *Federal Standards:*

Federal Test Method Standard 191b, Method 5903, Vertical Flame Resistance of Cloth¹¹

NFPA 701 National Fire Protection Standards—701 Standard Methods of Fire Tests for Flame Resistant Textiles and Films¹²

3. Terminology

3.1 *Definitions:*

3.1.1 *air-supported roof, n*—a fabric roof-system that is properly secured and primarily supported and held in place by air pressure.

3.1.2 *architectural-use, n*—in the building trade, a descriptive term for fabrics used in fabric roof-systems or similar industrial applications. (See also *fabric roof-system*)

3.1.3 *coated fabric, n*—a flexible material composed of a textile fabric and an adherent polymeric material applied to one or both surfaces. (See also *laminated fabric*)

3.1.4 *fabric roof-system, n*—a system of coated fabric or laminated fabric along with support cables, edge ropes, clamps, neoprene, roof drains, arch wear strips, and anchor bolts that constitutes the outside top covering of a building.

3.1.5 *laminated fabric, n*—in fabric roof-systems, a flexible material composed of superimposed layers of textile fabric firmly united by bonding or impregnating with an adherent polymeric material to one or more surfaces.

3.1.6 *tension-supported roof, n*—a fabric roof-system, that is properly secured and primarily held in place by tensile forces applied across the system.

3.1.7 For terminology of other textile terms used in this standard, refer to Terminology D 123. For definitions related to force and deformation in textiles, refer to Terminology D 4848.

4. Summary of Test Method

4.1 A summary of the directions prescribed for the determination of specific properties is stated in the appropriate sections of specific methods or in the referenced test methods.

5. Significance and Use

5.1 The procedures in this standard can be used for acceptance testing of commercial shipments of coated and laminated fabrics for architectural use since these test methods have been used extensively in the trade for acceptance testing. Caution is advised, however, when testing adhesion of coating to fabric and breaking strength after crease fold because between laboratory precision is known to be poor (see 24.2). For these cases, comparative tests conducted, as directed in 5.1.1, may be advisable.

5.1.1 In cases of a dispute arising from differences in reported test results when using Test Methods D 4851 for acceptance testing of commercial shipments, the purchaser and the supplier should conduct comparative tests to determine if there is a statistical bias between their laboratories. Competent statistical assistance is recommended for the investigation of bias. As a minimum, the two parties should take a group of test specimens which are as homogeneous as possible and from a lot of material of the type in question. The test specimens should then be randomly assigned in equal numbers to each laboratory for testing. The average results from the two laboratories should be compared using appropriate statistical analysis for unpaired data and an acceptable probability level chosen by the two parties before the testing is begun. If a bias is found, either its cause must be found and corrected or the purchaser and the supplier must agree to interpret future test results with consideration of the known bias.

5.2 The uses and significance of specific properties are discussed in the appropriate sections of specific test methods.

6. Sampling

6.1 *Lot Size*—The size of an acceptance sampling lot of fabric for architectural use shall be the number of fabric rolls in a shipment or consignment of a single fabric style unless otherwise agreed upon between the purchaser and supplier.

6.2 *Lot Sample*—Unless otherwise agreed upon, as when specified in an applicable order or contract, take as a lot sample the number of rolls in a shipment or consignment of fabric. Specify the number of rolls of fabric in the lot sample for each property of interest. Consider rolls of fabric to be the primary sampling units.

NOTE 1—An adequate specification or other agreement between the purchaser and supplier requires taking into account the variability between rolls of fabric and between specimens from a swatch or roll of fabric to provide a sampling plan with a meaningful producer's risk, consumer's risk, acceptable quality level, and limiting quality level.

6.3 *Laboratory Sample*—As a laboratory sample, take the following samples:

6.3.1 For fabric width, fabric bow, and fabric length, the rolls in the lot sample serve as the laboratory sample.

6.3.2 For noise reduction coefficient, flame resistance other than small scale NFPA 701, solar optical properties, and resistance to accelerated weathering, take as a laboratory sample a full-width swatch 12 m (12 yd) long from the end of each randomly selected roll in the lot sample as determined by agreement between the purchaser and supplier.

NOTE 2—Properties such as noise reduction coefficient, some flame resistance tests, solar optical, and resistance to weathering are dependent

⁹ Annual Book of ASTM Standards, Vol 14.02.

¹⁰ PC Programs on floppy disks are available through ASTM. For a 3½-in. disk request PCN:12-429040-18.

¹¹ Available from U.S. Government Printing Office, North Capital and H Streets, NW, Washington, DC 20401.

¹² Although discontinued by the National Fire Protection Association, this standard continues to be used by the industry.

upon fabric style and manufacturing processes. The extent of the sampling for these properties is usually defined in the applicable order or contract. Among the options available to the purchaser and the supplier is for the purchaser to accept a certification by the manufacturer that the material in question meets the specification agreed upon by the two parties and what the basis for the certification is, such as, historical data generated from material manufactured under the same conditions.

6.3.3 For other properties take as a laboratory sample a full-width swatch 1 m (1 yd) long from the end of each roll in the lot sample.

NOTE 3—The sample swatch, as in the laboratory sample, may be taken from the end of a roll if there is no visual evidence that the fabric is distorted or different from the fabric in other parts of the roll. In cases of dispute or if by visual evidence the outside fabric is not typical, take a sample swatch after excluding fabric from the outer wrap of the roll or the inner wrap of the core.

6.4 *Test Specimens*—For fabric width, fabric bow, and fabric length, the rolls in the lot sample serve as test specimens. For other properties, take test specimens from the swatches in the laboratory sample as directed in the respective test methods in this standard.

6.4.1 Take the specimens for the measurement of the machine direction properties from different positions across the fabric width and the specimens for the measurement of the cross-machine direction properties from different positions along the length of the fabric. Take no specimens nearer the selvage or edge of the fabric than $\frac{1}{10}$ the width of the fabric or 125 mm (5 in.) whichever is smaller.

7. Conditioning

7.1 Bring the specimens to moisture equilibrium in one of the following atmospheres:

7.1.1 *Option 1*—A temperature of $21 \pm 2^\circ\text{C}$ ($70 \pm 4^\circ\text{F}$) and relative humidity of $65 \pm 5\%$.

7.1.2 *Option 2*—A temperature of $23 \pm 2^\circ\text{C}$ ($73 \pm 4^\circ\text{F}$) and relative humidity of $50 \pm 5\%$.

NOTE 4—The intent of the two options for testing atmospheres is to allow testing of architectural fabrics in respective laboratories where products generally manufactured are related to a fabric laminating or coating discipline. In any event, the test atmosphere option shall be agreed upon by the contractual parties and stated in the report.

7.2 Equilibrium is considered to have been reached when the increase in mass of the specimen in successive weighings made at intervals of not less than 2 h does not exceed 0.1 % of the mass of the specimen. In general practice, the industry approaches equilibrium from the “As Received” side.

NOTE 5—It is recognized that in practice, coated and laminated fabrics are frequently not weighed to determine when moisture equilibrium has been reached. While such a procedure cannot be accepted in cases of dispute, it may be sufficient in routine testing to expose the material to the standard atmosphere for testing for a reasonable period of time before the specimens are tested. A time of at least 24 h has been found acceptable in most cases. However, certain fibers and coatings may exhibit slow moisture equalization rates from the “As Received” wet side. When this is known, a preconditioning cycle, as described in Practice D 1776 may be agreed upon between contractual parties.

8. Fabric Count

8.1 Determine the fabric count as directed in Test Method D 3775 making five counts in the machine direction and five

counts in the cross-machine direction on each of the swatches from the rolls in the laboratory sample.

9. Mass Per Unit Area

9.1 Determine the mass per unit area of the fabric as directed in Test Methods D 3776, Option C, using each of the rolls in the laboratory sample.

10. Thickness

10.1 Determine the thickness of the fabric as directed in Method D 1777 using ten test specimens from each roll in the laboratory sample and using the gage with a presser foot with a diameter of 9.5 ± 0.025 mm (0.375 ± 0.001 in.) that is weighted to apply a total force of 1.70 ± 0.03 N (6 ± 0.1 ozf) equivalent in pressure of 23.4 kPa (3.4 psi), unless otherwise specified.

11. Width

11.1 Determine the width of the fabric as directed in Test Method D 3774, Option A (full roll), using the tension free procedure, except make five measurements on each of the rolls in the lot sample.

12. Length

12.1 Measure the length of each roll in the lot sample as directed in Test Method D 3773 using Option B (Drum Method) or Option C (Clock Method). Verify that each sample roll does not contain more than one piece. Total the lengths of the rolls measured. Compare the length for each of the rolls tested to the length specified on the corresponding identification label.

13. Fabric Bow

13.1 Measure the fabric bow of each roll in the lot sample as directed in Test Method D 3882 in three places spaced as widely as possible along the roll length. Make no measurement closer to the ends of the roll than 1 m (1 yd).

14. Adhesion of Coating to Fabric

NOTE 6—**Precaution:** In addition to other precautions, when flammable or toxic adhesives are used for sealing, they should be cured in a well-ventilated area, for example, under a hood, to prevent accumulation of vapors. This is also applicable when sealing techniques that do not require adhesives are used.

14.1 Determine the coating adhesion in both machine direction and cross-machine direction as directed in Test Methods D 751, using two sets of specimens in both the machine direction and the cross-machine direction. Use a constant-rate-of-extension (CRE) type tensile testing machine operated at 50 ± 3 mm/min (2.0 ± 0.1 in./min) and report the rate used.

14.2 The use of hydraulic-pneumatic clamping systems with a minimum of 50 by 75 mm (2 by 3 in.) serrated jaw faces is recommended. Manual clamping is permitted if no slippage of the specimen is observed.

14.3 Run the test with the following exception: Prepare test specimens by sealing two material strips face to back.

14.4 Use the sealing method for seams typical to the material under test as defined in the Annexes or by an applicable contract or order. To facilitate separation later, do

not seal the upper 25 mm (1 in.) of specimen. Condition the specimens as specified in the sealing method before testing.

14.5 After conditioning, cut through a 25 by 200 mm (1 by 8 in.) strip of both layers of fabric from the center of each sealed double-layer strip. Strip the fabric from one layer down for a distance of 50 mm (2 in.).

14.9 *Calculation*—Calculate the average coating adhesion to the nearest 0.2 N/cm (0.1 lbf/in.) of width for each direction of each laboratory sampling unit and for the lot.

14.10 *Report*—Report that the specimens were tested as directed in Test Method D 4851 for adhesion of coating to fabric. Describe the material tested and the method of sam-

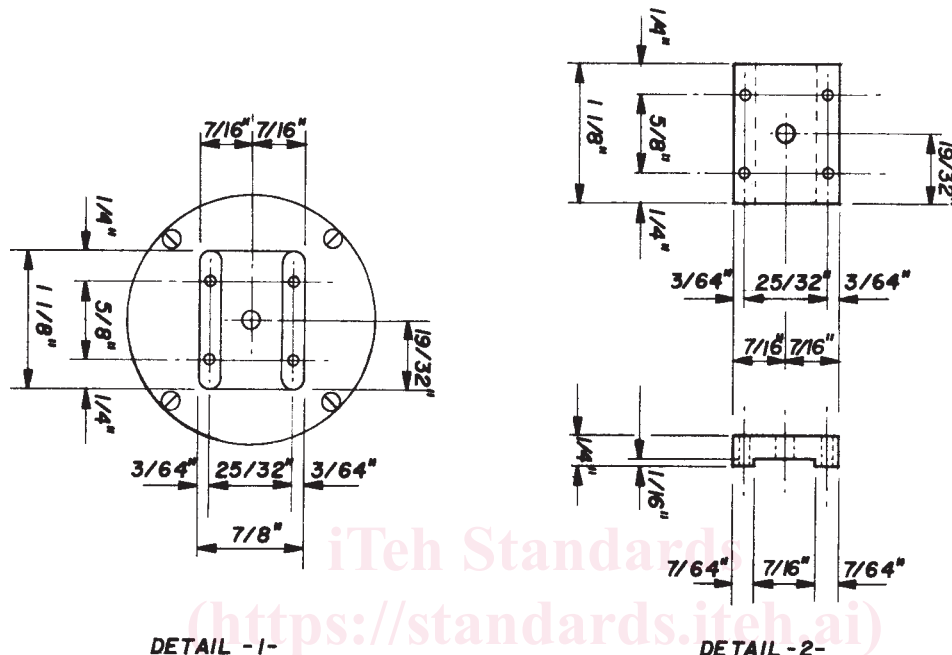

DETAIL - 1-

DETAIL - 2-

FIG. 1A
FIG. 1 Adjustable Pin Beam Compass

14.6 Clamp one end of the separated portion of the 25 mm (1 in.) strip in the lower jaw of the tensile testing machine and the other end of the specimen in the upper jaw.

14.7 Activate the crosshead and pull the specimen until a 100-mm (4-in.) separation of the bonded specimen has occurred. This equals 200 mm (8 in.) or crosshead movement.

14.8 Disregard the first inch of bonded specimen separation recorded. Record the average of the five highest force peaks of resistance as the adhesion of each specimen. Report the average value obtained and the type of failure. Note the type failure that occurs as one of the following:

14.8.1 *CAF*—Coating Adhesion Failure defined by separation of the coating and fabric.

14.8.2 *AAF*—Adhesive Adhesion Failure defined by separation of the coating and adhesive.

14.8.3 *AF*—Adhesive Failure defined by separation within the adhesive layer.

14.8.4 *P*—Prefix assigned when two failure conditions are observed in the same specimen.

14.8.5 *CF*—Coating Failure defined by separation within the coating.

14.8.6 *FF*—Fabric Failed in tension, no seam failure.

14.8.7 *DF*—Delamination between the layers of a laminated fabric.

pling. Report the coating adhesion for each laboratory sampling unit and for the lot.

14.11 *Precision and Bias*—The precision and bias of the procedure in Test Methods D 4851 for measuring the adhesion of the coating to the fabric are as specified in Methods D 751.

15. Uniaxial Elongation Under Static Force

15.1 *Scope*—This test method covers the measurement of the uniaxial elongation of fabric when subjected to a specified force. The force applied is dependent on the fabric mass and the end-use requirements.

15.2 *Summary of Test Method*—A unidirectional force is applied to one end of a specimen while the opposite end is fixed in a vertical position. After a fixed time period, the uniaxial elongation and use under the specified force is recorded.

15.3 *Significance and Use*—The property measured is the amount of elongation in a specific weave direction (machine or cross-machine) in a specific roll of fabric when subjected to a specified force. When combined with a knowledge of the biaxial elongation characteristics of a particular style of fabric, the amount of elongation is useful in determining the adjustments of patterns necessary to produce a stressed structure of predetermined dimensions.

15.4 Apparatus and Materials:

15.4.1 *Ruler*, 1 m with 0.5 mm divisions or 24 in. with 0.01 in. divisions.¹³

15.4.2 *Scriber*, steel, straight.¹⁴

15.4.3 *Knife*, razor type.

15.4.4 *Adjustable Pin Beam Compass*, with dial indicator in accordance with Fig. 1 or other equivalent measuring device.

15.4.5 *Static Load Test Rack*, in accordance with Fig. 2, or equivalent.

NOTE 7—The dimensions in Fig. 2 are for illustrative purposes. Although the static load test rack using the dimensions in Fig. 2 has been used in the industry, other test rack configurations can be constructed providing they meet the conditions of the uniaxial elongation under static force test procedure in this test method for the specimen size and static load requirements.

15.4.6 *Specimen Hold-Down Bar*—Fabricate a 380 by 38 mm (15 by 1.5 in.) bar made from 3-mm (1/8-in.) thick steel or aluminum with a 280 mm (11 in.) long by 9.5 mm (3/8 in.) slot in the middle.

15.4.7 *Force Gage*, 500 × 1.0 N (100 × 0.1 lbf).¹⁵

15.4.8 *Force Gage Mounting Bracket*—Fabricate a bracket with attached hooks to measure the force at the specimen holders in accordance with Fig. 3.

15.4.9 *Force Gage Verification Weight*, as specified in an applicable purchase order or contract.

15.4.10 *Timer*, to measure 8 h ± 10 min.

15.4.11 *Pencil*, or marking pen.

15.5 *Specimen Preparation*—Prepare four specimens from each swatch in the laboratory sample with the long dimension in the machine direction and with no two specimens from a swatch containing the same warp ends. Prepare four specimens from each swatch in the laboratory sample with the long dimension in the cross-machine direction and with no two specimens from a swatch containing the same filling ends. Cut four specimens 610 ± 13 by 25 mm (24 ± 1/2 by 1 in.) with the width being plus one yarn, minus zero yarns. If part of a yarn falls under the 25 mm (1 in.) mark, include the complete yarn in the specimen width. Cut the specimens so that yarns along the specimen edges are not nicked or cut. Specimens may not contain a fabric defect. Using a pencil or marking pen, mark each specimen near one end with the sample identification, location, and fabric direction.

NOTE 8—Cutting between yarns along the edges of specimens may be facilitated if a scribe is drawn, with heavy pressure, several times along the path of the intended cut.

15.6 Procedure:

¹³ Starrett No. 416R (CME600), or equivalent, has been found satisfactory for this purpose.

¹⁴ Snap-on Tool No. CM-3031, or equivalent, has been found satisfactory for this purpose.

¹⁵ Chatillon Model No. CFG-100, John Chatillon & Sons, Inc., 7609 Business Park Drive, Greensboro, NC 27409, or equivalent, has been found satisfactory for this purpose.

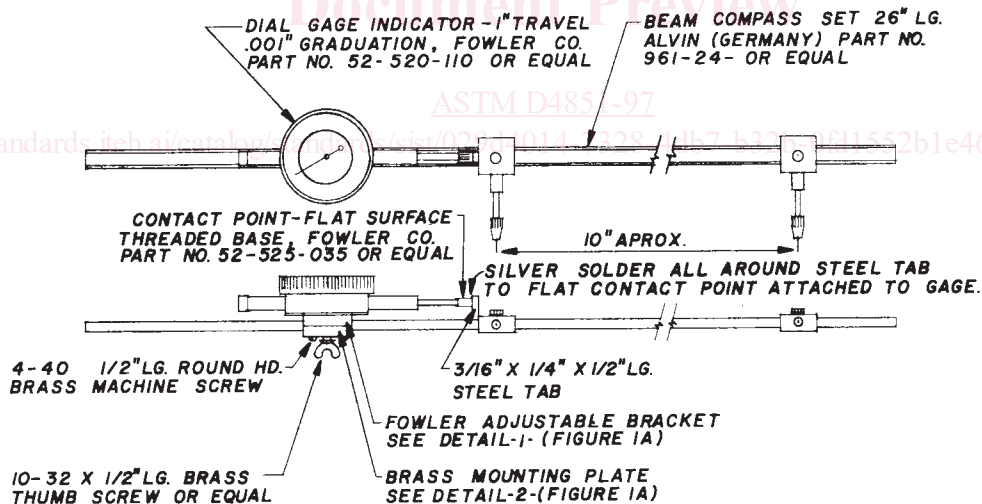

Metric Equivalents			
in.	mm	in.	mm
3/64	1	10/32	15
1/16	2	5/8	16
7/64	3	25/32	20
3/16	5	7/8	22
1/4	6	1	25
7/16	11	1 1/8	29
1/2	13	10	254
		26	660

FIG. 1 Adjustable Pin Beam Compass (continued)

ASTM D 4851 - 97

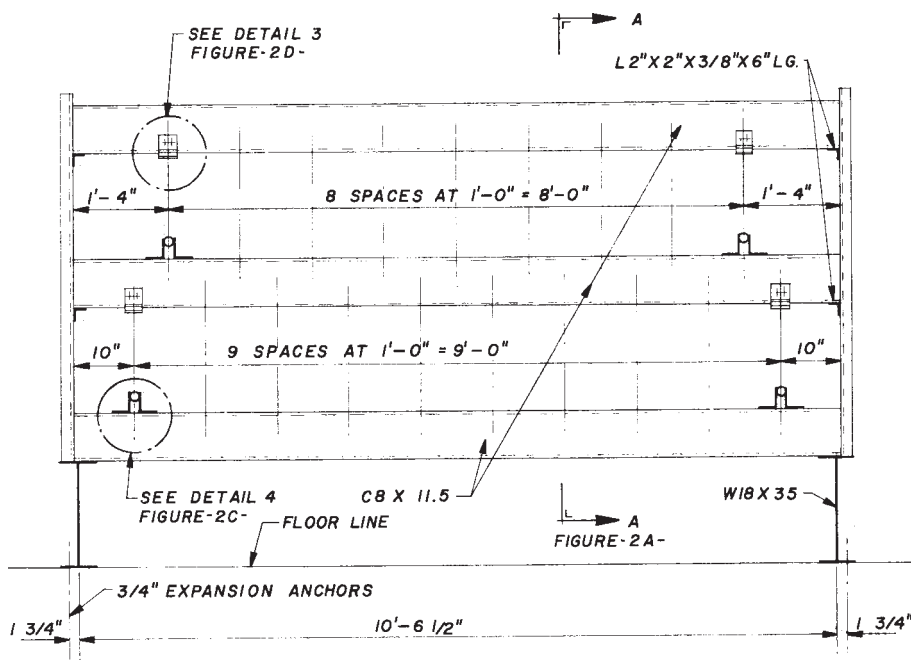

FIG. 2 Static Loading Test Rack

15.6.1 Zero the beam compass and set the span to 250 mm (10 in.) using the steel ruler.

15.6.2 Position the dial indicator about $\frac{1}{4}$ the distance from one end of the beam, with the measuring foot toward the long section of the beam. Secure the indicator to the beam with the locking screw.

15.6.3 Hold the beam compass in a vertical position with the dial indicator at the top.

15.6.4 Move the adjustable upper pin assembly until the small 0.25 mm (0.1 in.) division counter dial is on "zero."

15.6.5 Unlock the dial face and move the outer scale 0.025 mm (0.001 in.) division to "zero."

15.6.6 Using care not to move the upper pin, hold the ruler up to the pins and move the lower pin assembly until the distance between the pins is 250 ± 0.25 mm (10 ± 0.01 in.). Tighten the lower pin assembly locking screw.

15.6.7 Using the ruler again, move the upper pin assembly until the distance between the pins is 250 ± 0.25 mm (10 ± 0.01 in.).

15.6.8 Move the dial indicator scale again until the scale is at "zero." Tighten the dial scale lock.

15.6.9 Check that both dials on the indicator are on zero, then recheck the distance between the pins with the ruler. If not 250 ± 0.25 mm (10 ± 0.01 in.) on the ruler, repeat 15.6.7 and 15.6.8.

15.6.10 Perform the initial (zero force) fabric measurement.

15.6.10.1 With the specimen on a smooth table top, center the specimen hold-down bar lengthwise on the specimen. Center the slot between the sides of the specimen.

15.6.10.2 Place the stationary pin in the center of the slot about 13 mm ($\frac{1}{2}$ in.) from one end. With the point located between yarns, press it into the fabric far enough to leave a small hole in the coating.

15.6.10.3 With the adjustable pin in the center of the slot, observe where the pin touches the fabric. If it does not fall between yarns, increase the pin spacing by moving the adjustable pin assembly until that pin reaches the next space between yarns. Press the pin into the fabric, leaving a small hole in the coating and record the measurement to the nearest 0.025 mm (0.001 in.). Make and record a second reading by removing the beam compass, moving the adjustable pin several turns of the thumb wheel, and then making a second measurement. If the readings differ by more than 0.25 mm (0.010 in.), discard both readings and make two new measurements. If the readings still differ by more than 0.25 mm (0.010 in.), determine the cause and correct before continuing. Record the average of the two measurements as M_0 . When making measurements, any force on the pins will cause the pins or beam to deflect or the pinholes to become elongated and cause reading errors.

15.6.10.4 Remove the beam compass and circle both pinholes in the fabric with a marking pen.

15.6.10.5 Repeat 15.6.10.1-15.6.10.4 for each specimen.

15.6.11 Check the force gage zero and calibration against the verification weight, then check the test rack for force calibration by connecting the force gage from the top specimen holder to the lower holder. Adjust to the specified force.

15.6.12 Mount the specimens in the force rack.

15.6.13 Raise the force arm and insert the locking pin in the mounting bracket to hold the arm in the raised position.

15.6.14 Hold a specimen vertical with the upper pinhole approximately even with the lower bar of the upper specimen holder. Insert the upper end of the specimen over the upper bar and down behind both bars. Pull the inserted end forward, around the lower bar and bring it up behind and over the top bar (from back to front). Check to see that the pinhole is about 6 mm ($\frac{1}{4}$ in.) below the lower bar, align the end with the main portion of the specimen, and center the specimen in the holder.

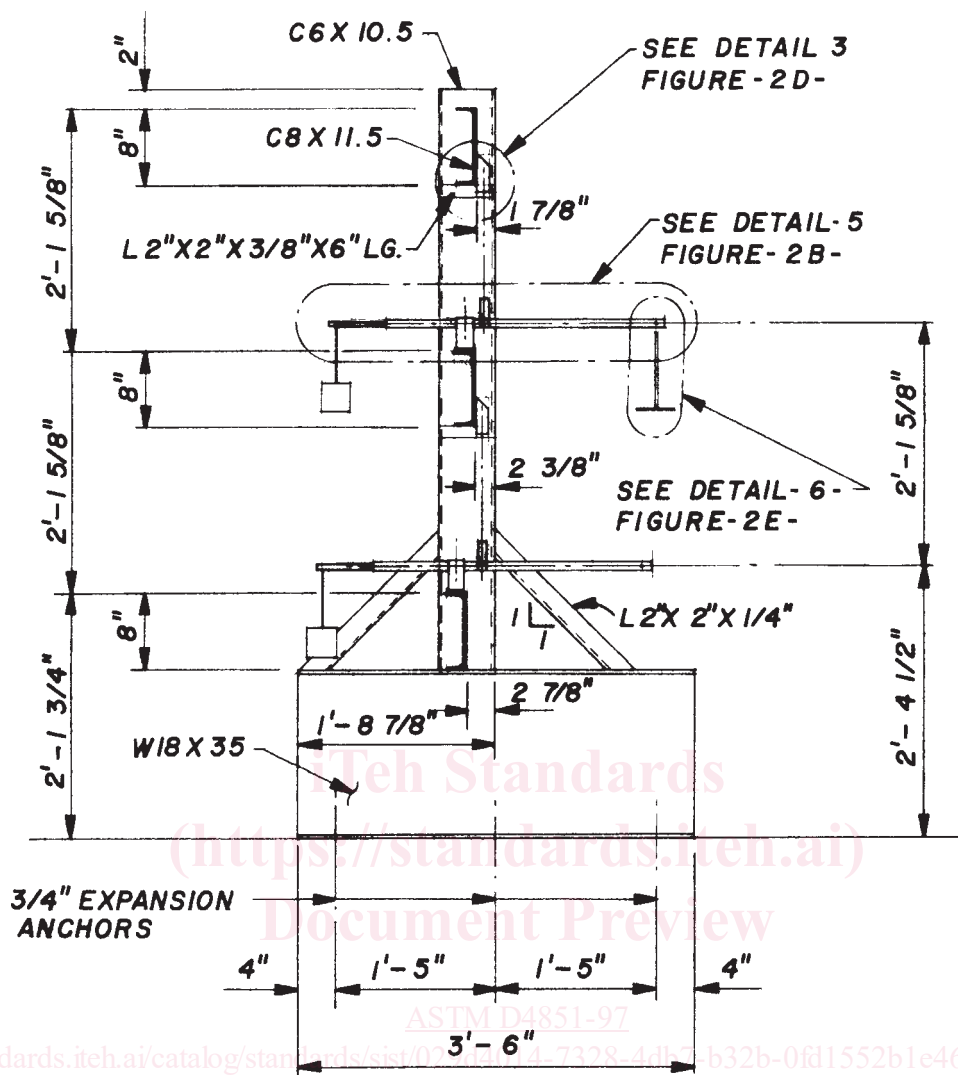

SECTION A-A

FIG. 2A
FIG. 2 Static Loading Rack (continued)

Pull down on the main portion of the specimen to lock the end between the upper bar and the main portion of the specimen (see Fig. 4).

15.6.15 Place the bottom end of the specimen around the lower bar of the bottom specimen holder and up behind both bars. Bring the end forward over the top bar and down around the lower bar (from back to front) and up behind the main portion of the specimen. Pull on the end and feed specimen through the holder until an appropriate amount of slack remains between the upper and lower holders.

NOTE 9—The amount of slack necessary to achieve an acceptable arm angle is estimated according to the fabric direction. Different fabric materials, fabric mass per unit areas, constructions and test forces will affect the amount of slack needed to level the arm assembly.

15.6.16 Raise the arm slightly and remove the locking pin. Slowly lower the arm, allowing more force to be applied until

the fabric ceases to elongate and supports the force entirely. Check the arm angle. If the end of the force arm is more than 50 mm (2 in.) above or below an imaginary line drawn at 1.57 radians (90°) to the specimen at the pivot point (see Fig. 4), lift the arm and lengthen or shorten the specimen as needed. Reapply the force very slowly and check the arm angle is within the 50 mm (2 in.) limits. Note the time the force is applied at the correct arm angle.

15.6.17 After 8 ± 0.25 h have passed since the application of the full force, remeasure the length of the specimen between the pinholes by placing the stationary pin of the beam compass in the lower pinhole, and moving the adjustable pin to mate with the upper pinhole. Measure the specimen length while under the fully applied force to the nearest 0.025 mm (0.001 in.). Remove the beam compass, move the adjustable pin to a different reading, and perform a second measurement. If the

ASTM D 4851 - 97

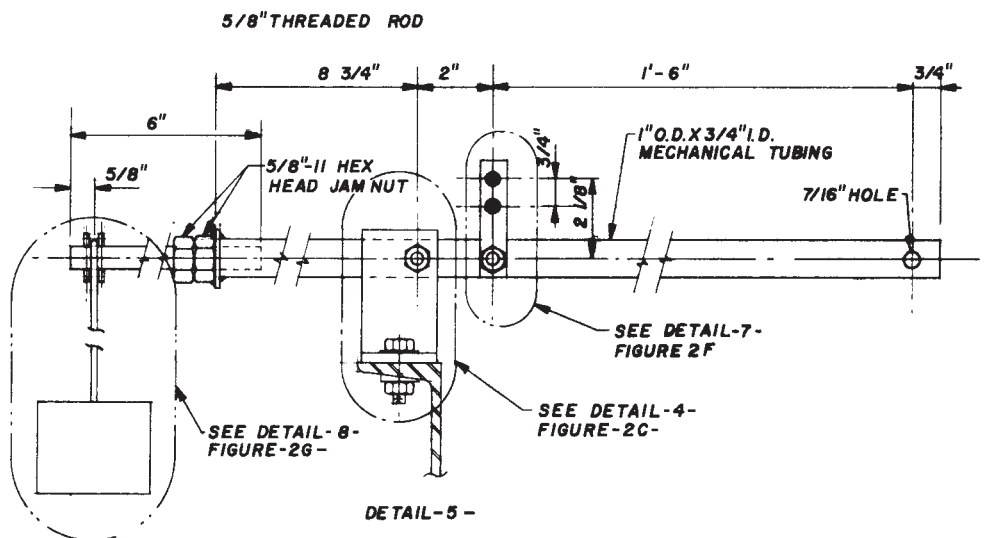
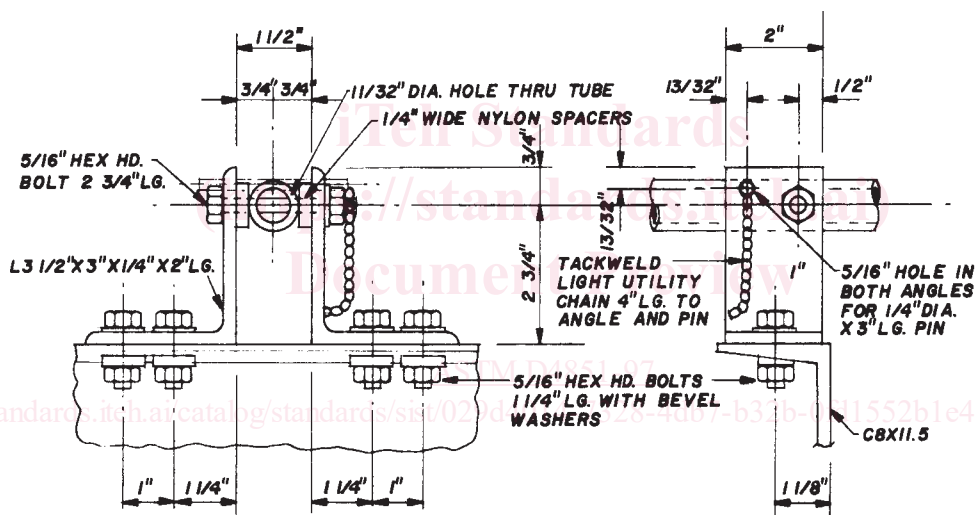

FIG. 2B
FIG. 2 Static Loading Rack (continued)



DETAIL-4-
FIG. 2C
FIG. 2 Static Loading Rack (continued)

values are within 0.25 mm (0.010 in.) of each other, report the average of the two measurements as M . If not within 0.25 mm (0.010 in.), take two additional measurements and discard the first two measurements. A measurement may be taken after 1 to 2 min have passed since the application of the full force. When requested, measure at other force/time intervals. Indicate the total time from the original force application with each set of measurements if different than specified.

15.7 Calculation:

15.7.1 Calculate the elongation under static load for each specimen to the nearest 0.01 % by Eq 1:

$$\epsilon = \frac{(M - M_0)}{M_0} \times 100 \quad (1)$$

where:

- ϵ = elongation, %,
- M = length measurement after application of full force (15.6.17), mm (in.), and
- M_0 = length measurement before application of force (15.6.10.2), mm (in.).

15.7.2 Calculate the average elongation under static load for each direction of each laboratory sampling unit and for the lot.

15.8 Report:

15.8.1 State that the specimens were tested as directed in Test Method D 4851 for uniaxial elongation under static load. Describe the material and the method of sampling used.

15.8.2 Report the following information:

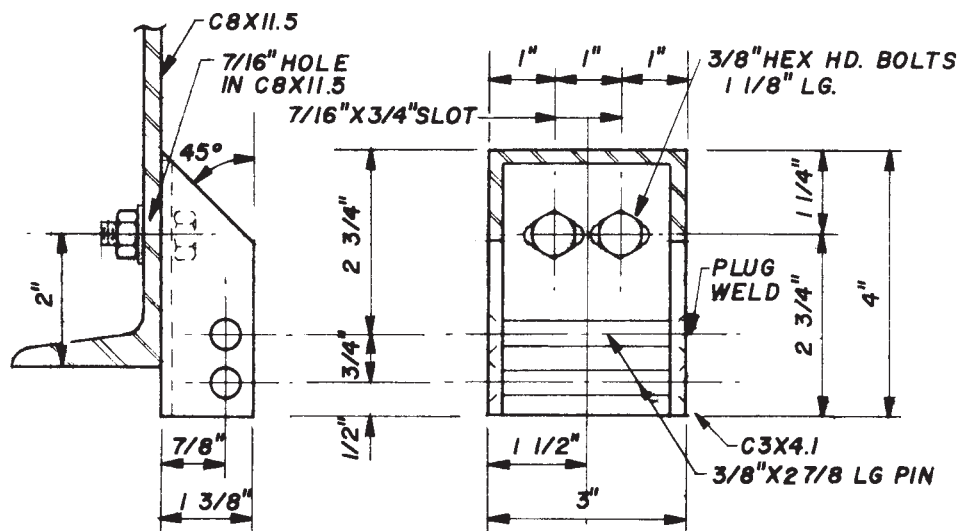

DETAIL-3-

FIG. 2D

FIG. 2 Static Loading Rack (continued)

15.8.2.1 The force applied and the test duration.

15.8.2.2 The average elongation under static load for each direction of each laboratory sampling unit and for the lot.

15.9 Precision and Bias:

15.9.1 Precision—The precision of Test Methods D 4851 for uniaxial elongation under static force of fabrics for architectural use is given in 24.2.

15.9.2 Bias—The uniaxial elongation under static force of fabrics for architectural use can only be defined in terms of a specified test method. Within this limitation, the procedure for uniaxial elongation under static force in Test Methods D 4851 has no known bias.

16. Breaking Force

16.1 Determine the breaking force in kN/m (lbf/in.) of fabric in both the machine direction and cross-machine direction as directed in Test Method D 5035, 25.4-mm (1-in.) cut strip excluding preconditioning, using five specimens in both the machine direction and cross-machine direction. When required, conduct tests in both the wet and dry condition. Use a CRE type tensile testing machine operated at 50 ± 3 mm/min (2.0 ± 0.1 in./min) unless specified otherwise. The distance between clamps shall be 75 ± 1 mm (3.0 ± 0.05 in.).

16.1.1 The use of hydraulic or pneumatic clamping systems with a minimum of 50 by 75 mm (2 by 3 in.) serrated jaw faces having a clamping force at the grip face of 10 to 14 kN (2000 to 3100 lbf) is recommended. The 75 mm (3.0 in.) dimension of the jaw face is preferred in the direction of test; however, the 50 mm (2.0 in.) dimension is permitted. Manual clamping is permitted providing no slippage of the specimen is observed. Regardless of the clamp size or jaw orientation, use a gage length of 75 ± 1 mm (3.0 ± 0.05 in.).

16.1.2 When using jaw faces other than serrated, such as rubber-faced jaws, they may be covered with a No. 80 medium

grit emery cloth. Secure the emery cloth to the jaw faces with pressure sensitive tape.

16.1.3 From each swatch in the laboratory sample, cut and label five test specimens in the machine direction and five test specimens in the cross-machine direction. Cut the test specimens long enough to extend through the clamps and project at least 10 mm (0.5 in.) at each end. Make the total number of lengthwise yarns in each specimen equal to the yarn count per 25.4 mm (1 in.) in that direction. Take care that the long side of each test specimen follows a yarn component even if the long side of the test specimen is not a straight line. Cut the test specimens in the cross-machine direction adjacent to test specimens cut in the machine direction.

NOTE 10—The use of transmitted light may help to guide the cutting edge along the yarn component. For fabrics with severe weave distortion, it may be necessary to free-hand cut the specimens to permit following the yarn contours and avoiding nicking the outside yarns. The correct number of yarns in the lengthwise direction of the specimen must be maintained even if the width of the specimen varies from 25.4 mm (1 in.).

16.1.4 When both wet and conditioned breaking force of fabric are required, run paired breaks on test specimens containing the same yarns by cutting each test specimen at least twice as long as required for a conditioned test. Number each specimen at each end and then cut crosswise into two parts, one for determining the wet breaking force. Prepare specimens for wet breaking force by soaking 24 ± 1.0 h under 75 to 100 mm (3 to 4 in.) of distilled water at 21 to 27°C (70 to 80°F). After soaking 24 h, remove the specimens, pat dry with an absorbent paper towel, and test within 5 min of removal from the water.

16.2 Precision and Bias—The precision and bias of the procedure in Test Methods D 4851 for measuring breaking strength are as specified in Test Method D 5035.

ASTM D 4851 - 97

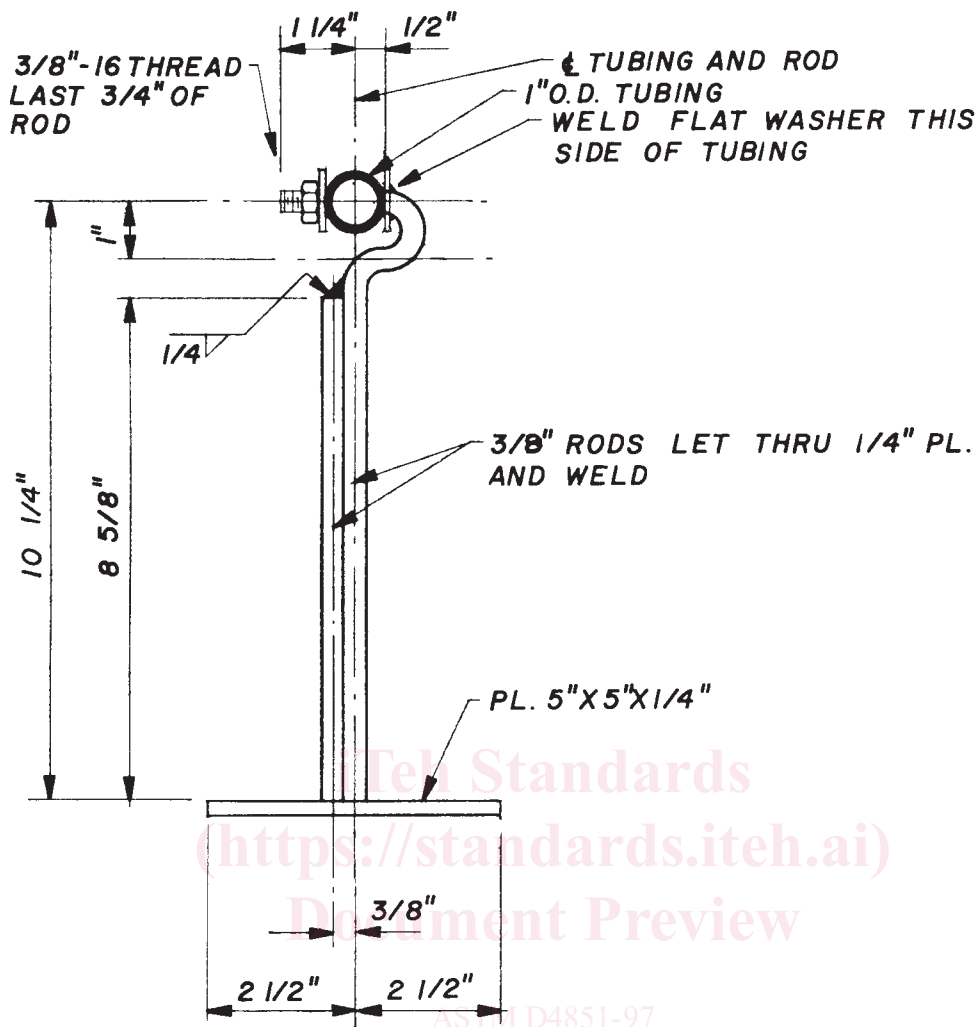

DETAIL - 6 -

FIG. 2E
FIG. 2 Static Loading Rack (continued)

17. Breaking Force After Crease Fold

17.1 *Scope*—This test method determines the resistance to creasing and folding by measuring the breaking force after repeated folding and force applications.

17.2 *Summary of Method*—A strip of fabric is folded and the looped end rolled with a cylinder of specified mass. A specimen containing the fold is cut from the folded strip and broken on a CRE-type tensile testing machine.

17.3 *Significance and Use*—Fabric sections are subjected to repeated folding and force applications to folds during packaging and fabrication. This method is intended to determine the breaking force after these repeated foldings and force applications. Test Method D 4851 for determining breaking force after crease-fold is useful for judging the compliance of shipments with material specifications.

17.4 *Apparatus and Materials:*

17.4.1 *Constant-Rate-of-Extension (CRE) Tensile Testing Machine*, with clamp control as prescribed in the breaking force section of this standard.

17.4.2 *Mass*, 4.5 kg (10 lb), cylindrical, approximately 90 mm (3.5 in.) diameter by 100 mm (4 in.) length.

17.4.3 *Knife*, razor type, for specimen cutting.

17.4.4 *Steel Rule*, 300 mm (12 in.) by 25 mm (1 in.) with 2 mm (1/16 in.) divisions.

17.5 *Sample Preparation:*

17.5.1 Unroll the sample on a smooth, flat surface.

17.5.2 Using a steel rule and razor knife, cut five 50 by 200 mm (2 by 8 in.) specimens each in the machine and cross-machine directions. No two specimens shall contain the same warp yarns for the machine direction test or the same filling yarns for the cross-machine direction test. Take no specimen nearer the selvage than 1/10 of the fabric width.