



Designation: D4254-91 (Reapproved 1996)

Standard Test Method for Designation: D 4254 – 00 (Reapproved 2006)^{ε1}

Standard Test Methods for Minimum Index Density and Unit Weight of Soils and Calculation of Relative Density¹

This standard is issued under the fixed designation D 4254; the number immediately following the designation indicates the year of original adoption or, in the case of revision, the year of last revision. A number in parentheses indicates the year of last reapproval. A superscript epsilon (ε) indicates an editorial change since the last revision or reapproval.

This standard has been approved for use by agencies of the Department of Defense.

^{ε1} NOTE—Corrected research report reference in Section 12 editorially in March 2008.

1. Scope

~~1.1 These test methods cover the determination of the minimum index density/unit weight of cohesionless, free-draining soils.~~

*

1.1 These test methods cover the determination of the minimum-index dry density/unit weight of cohesionless, free-draining soils. The adjective “dry” before density or unit weight is omitted in the title and remaining portions of this standards to be consistent with the applicable definitions given in Section 3 on Terminology.

1.2 System of units:

1.2.1 The testing apparatus described in this ~~test method standard~~ has been developed and manufactured using values in the gravimetric or inch-pound system. Therefore, test apparatus dimensions and mass given in inch-pound units are regarded as the standard.

1.2.2 It is common practice in the engineering profession to concurrently use pounds to represent both a unit of mass (lbm) and a unit of force (lbf). This implicitly combines two separate systems of units; that is, the absolute system and the gravitational system. It is scientifically undesirable to combine the use of two separate sets of inch-pound units within a single standard. This test method has been written using the gravitational system of units when dealing with the inch-pound system. In this system, the pound (lbf) represents a unit of force (weight). However, balances or scales measure mass; and weight must be calculated. In the inch-pound system, it is common to assume that 1 lbf is equal to 1 lbm. While reporting density is not regarded as nonconformance with this ~~test method standard~~, unit weights should be calculated and reported since the results may be used to determine force or stress.

1.2.3 The terms density and unit weight are often used interchangeably. Density is mass per unit volume, whereas unit weight is force per unit volume. In this ~~test method standard~~, density ~~shall be~~ is given only in SI units. After the density has been determined, ~~calculations for determining unit weights shall be given.~~ the unit weight is calculated in SI or inch-pound units, or both.

1.3 Three alternative ~~procedures~~ methods are provided to determine the minimum index density/unit weight, as follows:

~~1.3.1 Test Method 1.3.1 Method A~~—Using a funnel pouring device or a hand scoop to place material in mold.

~~1.3.2 Test Method 1.3.2 Method B~~—Depositing material into a mold by extracting a soil filled tube.

~~1.3.3 Test Method C~~—~~Depositing~~ 1.3.3 Method C²—Depositing material by inverting a graduated cylinder.

1.4 The ~~test method~~ to be used should be specified by the individual assigning the test. If no ~~test method~~ is specified, the provisions of ~~Test Method A~~ shall govern. Test Method A is the preferred procedure for determining minimum index density/unit

⁴ This test method is under the jurisdiction of ASTM Committee D-18 on Soil and Rock and is the direct responsibility of Subcommittee D18.03 on Texture, Plasticity, and Density Characteristics of Soils.

Current edition approved Aug. 15, 1991. Published November 1991. Originally published as D4254-83. Last previous edition D4254-83.

¹ This standard is under the jurisdiction of ASTM Committee D18 on Soil and Rock and is the direct responsibility of Subcommittee D18.03 on Texture, Plasticity and Density Characteristics of Soils.

Current edition approved Feb. 1, 2006. Published March 2006. Originally approved in 1983. Last previous edition approved in 2000 as D 4254 – 00.

² Annual Book of ASTM Standards, Vol 04.02.

³ Kolbuszewski, J. J., “An Experimental Study of the Maximum and Minimum Porosities of Sands,” *Proceedings, Second International Conference on Soil Mechanics and Foundation Engineering*, Rotterdam Vol I, 1948, pp. 158–165.

*A Summary of Changes section appears at the end of this standard.

weight as used in conjunction with the procedures of Test Methods D 4253. Test Methods B and C are provided for guidance of testing used in conjunction with special studies, especially where there is not enough material available to use a 0.100 ft³ (2 830 cm³) or 0.500 ft³ (14 200 cm³) mold as required by Test Method A.

1.5 These test methods are applicable to soils that may contain up to 15 %, by dry mass, of soil particles passing a No. 200 (75- μ m) sieve, provided they still have cohesionless, free-draining characteristics (nominal sieve dimensions are in accordance with Specification E 11).

~~1.5.1 Test Method~~ **1.5.1 Method A** is applicable to soils in which 100 %, by dry mass, of soil particles pass a 3-in. (75-mm) sieve and which may contain up to 30 %, by dry mass, of soil particles retained on a 1-1/2-inch (37.5-mm) sieve.

~~1.5.2 Test Method~~ **1.5.2 Method B** is applicable to soils in which 100 %, by dry mass, of soil particles pass a 3/4-inch (19.0-mm) sieve.

~~1.5.3 Test Method~~ **1.5.3 Method C** is applicable only to fine and medium sands in which 100 %, by dry mass, of soil particles pass a 3/8-in. (9.5-mm) sieve and which may contain up to 10 %, by dry mass, of soil particles retained on a No. 10 (2.00-mm) sieve.

1.5.4 Soils, for the purposes of these test methods, shall be regarded as naturally occurring cohesionless soils, processed particles, or composites or mixtures of natural soils, or mixtures of natural and processed particles, provided they are free-draining.

1.6 *This standard does not purport to address all of the safety concerns, if any, associated with its use. It is the responsibility of the user of this standard to establish appropriate safety and health practices and determine the applicability of regulatory limitations prior to use.*

2. Referenced Documents

2.1 ASTM Standards:

~~C 127 Test Method for Specific Gravity and Absorption of Coarse Aggregate~~ Test Method for Density, Relative Density (Specific Gravity), and Absorption of Coarse Aggregate

~~D 422 Test Method for Particle-Size Analysis of Soils~~

~~D 653 Terminology Relating to Soil, Rock, and Contained Fluids~~

~~D 854 Test Method for Specific Gravity of Soils³~~ Test Methods for Specific Gravity of Soil Solids by Water Pycnometer

~~D 1140 Test Methods for Amount of Material in Soils Finer than No. 200 (75-m) Sieve~~

~~D 2216 Test Method for Laboratory Determination of Water (Moisture) Content of Soil, Rock, and Soil-Aggregate Mixtures³~~ Test Methods for Laboratory Determination of Water (Moisture) Content of Soil and Rock by Mass

~~D 2487 Test Method for Classification of Soils for Engineering Purposes³~~ Practice for Classification of Soils for Engineering Purposes (Unified Soil Classification System)

~~D 2488 Practice for Description and Identification of Soils (Visual-Manual Procedure)~~

~~D 4253 Test Methods for Maximum Index Density of Soils Using a Vibratory Table³~~ 3740 Practice for Minimum Requirements for Agencies Engaged in the Testing and/or Inspection of Soil and Rock as Used in Engineering Design and Construction

~~D 4753 Specification for Evaluating, Selecting, and Specifying Balances and Scales for Use in Soil and Rock Testing³~~ 4253 Test Methods for Maximum Index Density and Unit Weight of Soils Using a Vibratory Table

~~D 4753 Guide for Evaluating, Selecting, and Specifying Balances and Standard Masses for Use in Soil, Rock, and Construction Materials Testing~~

~~D 6026 Practice for Using Significant Digits in Geotechnical Data~~

~~E 11 Specification for Wire-Cloth Sieves for Testing Purposes~~

~~E 319 Methods of Testing Single-Arm Balances⁴~~

Specification for Wire Cloth and Sieves for Testing Purposes

~~E 380 Practice for Use of the International System of Units (SI) (The Modernized Metric System)⁴~~ 177 Practice for Use of the Terms Precision and Bias in ASTM Test Methods

E 691 Practice for Conducting an Interlaboratory Study to Determine the Precision of a Test Method

3. Terminology

~~3.1 Definitions of Terms Specific to This Standard:~~

~~3.1.1 Except as listed below, all definitions are in accordance with Terminology D 653.~~

~~3.1.2 maximum index density/unit weight, ρ_{dmax} or γ_{dmax} —the reference dry density/unit weight of a soil in the densest state of compactness that can be attained using a standard laboratory compaction procedure that minimizes particle segregation and breakdown.~~

~~3.1.3 minimum index void ratio, e_{min} —the reference void ratio of a soil at the maximum index density/unit weight.~~

~~3.1.4 minimum index density/unit weight ρ_{dmin} or γ_{dmin} —the reference dry density/unit weight of a soil in the loosest state of compactness at which it can be placed using a standard laboratory procedure that prevents bulking and minimizes particle segregation.~~

3.1 Definitions: For common definitions in this standard refer to Terminology D 653

3.2 Definitions of Terms Specific to This Standard:

3.2.1 maximum index void ratio, e_{max} —the reference void ratio of a soil at the minimum index density/unit weight. ~~dry~~

density/unit weight ρ_d or γ_d , n —the dry density/unit weight of a soil deposit or fill at the given void ratio.

3.2.2 *given void ratio*, e , n —the in-situ or stated void ratio of a soil deposit or fill.

3.2.3 *dry density/unit weight ρ_d or γ_d* —the dry density/unit weight of a soil deposit or fill at the given void ratio. *maximum index density/unit weight*, ρ_{dmax} or γ_{dmax} , n —the reference dry density/unit weight of a soil in the densest state of compactness that can be attained using a standard laboratory compaction procedure that minimizes particle segregation and breakdown.

3.2.4 *relative density*, D_r , *maximum-index void ratio*, e_{max} , n —the reference void ratio of a soil at the minimum index density/unit weight.

3.2.5 *minimum index density/unit weight* ρ_{dmin} or γ_{dmin} , n —the reference dry density/unit weight of a soil in the loosest state of compactness at which it can be placed using a standard laboratory procedure that prevents bulking and minimizes particle segregation.

3.2.6 *minimum-index void ratio*, e_{min} , n —the reference void ratio of a soil at the maximum index density/unit weight.

3.2.7 *relative density*, D_d , n —the ratio, expressed as a percentage, of the difference between the maximum index void ratio and any given void ratio of a cohesionless, free-draining soil to the difference between its maximum and minimum index void ratios. The equation is:

$$D_d = \frac{e_{max} - e}{e_{max} - e_{min}} \times 100 \quad (1)$$

$$D_d = \frac{e_{max} - e}{e_{max} - e_{min}} \times 100 \quad (1)$$

or, in terms of corresponding dry densities:

$$D_d = \frac{\rho_{dmax}(\rho_d - \rho_{dmin})}{\rho_d(\rho_{dmax} - \rho_{dmin})} \times 100 \quad (2)$$

$$D_d = \frac{\rho_{dmax}(\rho_d - \rho_{dmin})}{\rho_d(\rho_{dmax} - \rho_{dmin})} \times 100 \quad (2)$$

or, in terms of corresponding dry unit weights:

$$D_d = \frac{\gamma_{dmax}(\gamma_d - \gamma_{dmin})}{\gamma_d(\gamma_{dmax} - \gamma_{dmin})} \quad (3)$$

$$D_d = \frac{\gamma_{dmax}(\gamma_d - \gamma_{dmin})}{\gamma_d(\gamma_{dmax} - \gamma_{dmin})} \quad (3)$$

3.1.9)

3.2.8 *density index/unit weight*, I_d , n —the ratio, expressed as a percentage, of the difference between any given dry density/unit weight and the minimum index density/unit weight of a given cohesionless soil to the difference between its maximum and minimum index densities/unit weights. The equation is:

$$I_d = \frac{\rho_d - \rho_{dmin}}{\rho_{dmax} - \rho_{dmin}} \times 100 \quad (4)$$

$$I_d = \frac{\rho_d - \rho_{dmin}}{\rho_{dmax} - \rho_{dmin}} \times 100 \quad (4)$$

or, in terms of corresponding dry unit weights:

$$I_d = \frac{\gamma_d - \gamma_{dmin}}{\gamma_{dmax} - \gamma_{dmin}} \quad (5)$$

$$I_d = \frac{\gamma_d - \gamma_{dmin}}{\gamma_{dmax} - \gamma_{dmin}} \quad (5)$$

— $\gamma_{dmin} \times 100$

4. Summary of Test Methods

4.1 The minimum index density/unit weight represents the loosest condition of a cohesionless, free-draining soil that can be attained by a standard laboratory procedure, which prevents bulking and minimizes particle segregation. Any particular procedure selected will consist of determining the density/unit weight of oven-dried soil placed into a container of known volume in such a manner that prevents bulking and particle segregation, and minimizes compaction of the soil.

5. Significance and Use

5.1 The density/unit weight of a cohesionless soil may be determined by various in-place methods in the field or by the measurement of physical dimensions and masses by laboratory soil specimens. The dry density/unit weight of a cohesionless soil does not necessarily, by itself, reveal whether the soil is loose or dense.

5.2 Relative density/unit weight expresses the degree of compactness of a cohesionless soil with respect to the loosest and densest condition as defined by standard laboratory procedures. Only when viewed against the possible range of variation, in terms of relative density/unit weight, can the dry density/unit weight be related to the compaction effort used to place the soil in a

compacted fill or indicate volume change and stress-strain tendencies of soil when subjected to external loading.

5.3 An absolute minimum density/unit weight is not necessarily obtained by these test methods.

NOTE 1—In addition, there are published data to indicate that these test methods have a high degree of variability.³ However, the variability can be greatly reduced by careful calibration of equipment, including the vibrating table, and careful attention to proper test procedure and technique.

5.4 The use of the standard molds (6.3.1) has been found to be satisfactory for most soils requiring minimum index density/unit weight testing. Special molds (6.3.2) shall only be used when the test results are to be applied in conjunction with design or special studies and there is not enough soil to use the standard molds. Such test results should be applied with caution, as minimum index densities/unit weights obtained with the special molds may not agree with those that would be obtained using the standard molds.) shall only be used when the test results are to be applied in conjunction with design or special studies and there is not enough soil to use the standard molds. Such test results should be applied with caution, as minimum index densities/unit weights obtained with the special molds may not agree with those that would be obtained using the standard molds.

NOTE 2—The quality of the result produced by this standard is dependent on the competence of the personnel performing it, and the suitability of the equipment and facilities used. Agencies that meet the criteria of Practice D 3740, generally, are considered capable of competent and objective testing/sampling/inspection/etc. Users of this standard are cautioned that compliance with Practice D 3740 does not in itself assure reliable results. Reliable results depend on many factors; Practice D 3740 provides a means of evaluating some of those factors.

6. Apparatus

6.1 *Apparatus for Test Methods A, B, and C:*

6.1.1 *Drying Oven*, thermostatically controlled, preferably of the forced-draft type, capable of maintaining a uniform temperature of $230 \pm 9^\circ\text{F}$ ($110 \pm 5^\circ\text{C}$) throughout the drying chamber.

6.1.2 *Sieves*, 3-in. (75-mm), 1-1/2-in. (37.5-mm), 3/4-in. (19-mm), 3/8-in. (9.5-mm), No. 4 (4.75-mm), No. 10 (2.00-mm), and No. 200 (75- μm) conforming to the requirements of Specification E 11.

6.2 The apparatus for determining the minimum index density/unit weight of cohesionless soil by Test Methods A and B is specified in 6.3. Apparatus required for Test Method C is specified in 6.4.

6.3 *Apparatus for Test Methods A and B:*

6.3.1 *Standard Molds*—Cylindrical metal molds having nominal volumes of 0.1000 ft³ (2 830 cm³) and 0.500 ft³ (14 200 cm³). The molds shall conform to the requirements shown in Fig. 1. The actual volume of the molds shall be within $\pm 1.5\%$ of the specified nominal volume.

6.3.2 *Special Molds*—Cylindrical metal molds having a capacity less than 0.100 ft³ (2 830 cm³), an inside diameter equal to or greater than 2-3/4 in. (70 mm) but less than 4 in. (100 mm) and conforming to the design methodology presented in Fig. 2. Such molds may only be used when the test results are to be used in conjunction with design or special studies, and there is not enough soil to use the 0.100 ft³ (2 830 cm³) mold.

6.3.3 *Balances(s)*, of sufficient capacity to determine the total mass of the specimen and mold, having sufficient accuracy that the mass of the soil is determined to the nearest 0.1 %. Balances capable of satisfying these requirements for most conditions have specifications as follows:

6.3.3.1 For 0.500-ft³

6.3.3.1 For 0.500-ft³ (14 200-cm³) molds, use a balance having a minimum capacity of 40-kg and meeting the requirements of Specification D 4753 for a Class GP 10 (readability of 5 g).

6.3.3.2 For 0.100-ft³ (2 830-cm³) molds, use a balance having a minimum capacity of at least 15 kg and meeting the requirements of Specification D 4753 for Class GP 5 (readability of 1 g).

6.3.3.3 For special molds that are less than 0.1 ft³ (2 830 cm³) in capacity, use a balance having a minimum capacity of at least 2 kg and meeting the requirements of Specification D 4753 for a Class GP 2 (readability of 0.1 g).

6.3.4 *Pouring Devices*—The pouring devices are used in conjunction with the 0.100 ft³ (2 830 cm³) standard mold and with special molds. Pouring devices consist of relatively rigid containers having volumes about 1.25 to 2 times greater than the volumes of the mold(s) used, and fitted with spouts or tubes about 6 in. (150 mm) long. Two pouring spouts are required, one having an inside spout diameter of 0.50 in. (13 mm) and another with an inside spout diameter of 1.0 in. (25 mm). A lipped brim, or other means, must be provided to securely connect the spout to the container that permits free and even flow of the soil from the container into the spout, and then into the mold.

6.3.5 *Rigid, Thin-Walled Tubes*, for use with Test Method B. The size of the tubes is dependent upon the mold size selected. The volume of the tubes shall be between 1.25 and 1.30 times the volume of the mold. The inside diameter of the tube shall be about 0.7 times the inside diameter of the mold.

6.3.6 Other equipment such as mixing pans, a large metal scoop, a hair-bristled dusting brush, and a metal straightedge (for trimming excess soil after it has been placed in the mold).

6.4 *Apparatus for Test Method C:*

6.4.1 *Glass Graduated Cylinder*, having a volume of 2000 mL, graduated to 20 mL, with about a 3-in. (75-mm) inside diameter.

³ Annual Book of ASTM Standards, Vol 04.08.

³ Selig, E. T., and Ladd, R. S., eds., *Evaluation of Relative Density and its Role in Geotechnical Projects Involving Cohesionless Soils*, ASTM STP 523, ASTM, 1973.

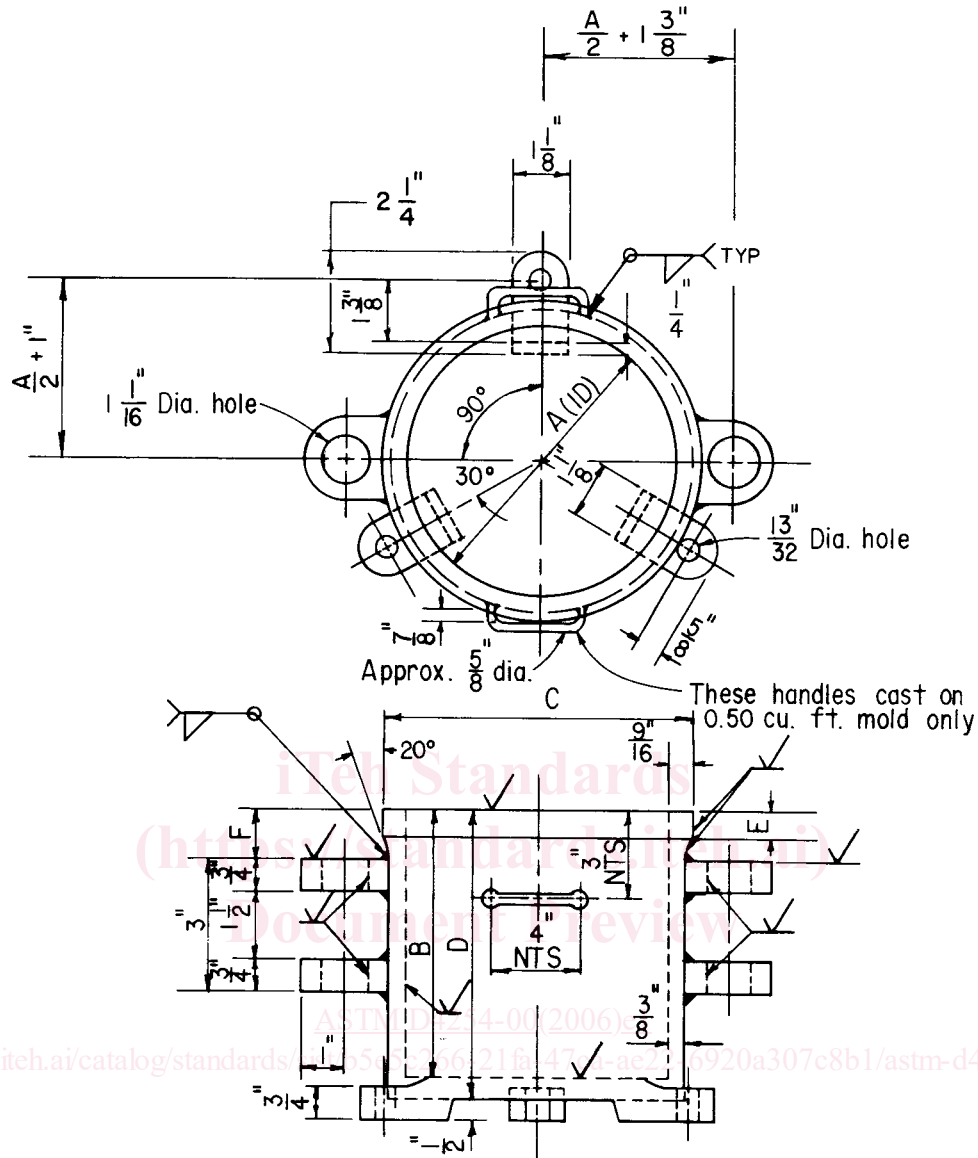

NOTE 1—Tolerances are $\pm 1/64$ in. (± 0.4 mm) unless otherwise noted.

Size Mold, ft ³ (cm ³)	Dimensions, in. (mm)					
	A $\begin{matrix} +0.005 \\ -0.000 \end{matrix}$	B $\begin{matrix} +0.005 \\ -0.000 \end{matrix}$	C	D	E	F
0.100 (2830)	6.000 (152.4)	6.112 (155.2)	7 $\frac{1}{8}$ (181.0)	6 $\frac{1}{2}$ (105.1)	$\frac{1}{2}$ (12.7)	1 $\frac{1}{8}$ (28.6)
0.500 (14 200)	11.000 (279.4)	9.092 (230.9)	12 $\frac{1}{8}$ (308.0)	9 $\frac{1}{2}$ (241.3)	$\frac{3}{8}$ (15.9)	2 (50.8)

FIG. 1 Details of Molds

6.4.2 Balance, of at least 2 kg capacity and otherwise consistent with 6.3.3.3.

6.4.3 Sieves, $\frac{3}{8}$ -in. (9.5-mm), No. 10 (2.00-mm), and No. 200 (75- μ m) sieves conforming to the requirements of Specification E 11.

7. Sampling and Test Specimen

7.1 Sampling and test specimen requirements for Test Methods A and B are contained in the following paragraphs. Requirements for Test Method C begin at Sampling and Test Specimen

7.1 Prior to testing, the sample should be stored in a manner to prevent freezing, contamination with other matter, loss of soil, or loss of identification.

7.2 Sampling and test specimen requirements for Methods A and B are contained in the following paragraphs. Requirements for Method C begin at 7.4.

7.2 Prior to testing, the sample should be stored in a manner to prevent freezing, contamination with other matter, loss of soil, or loss of identification.

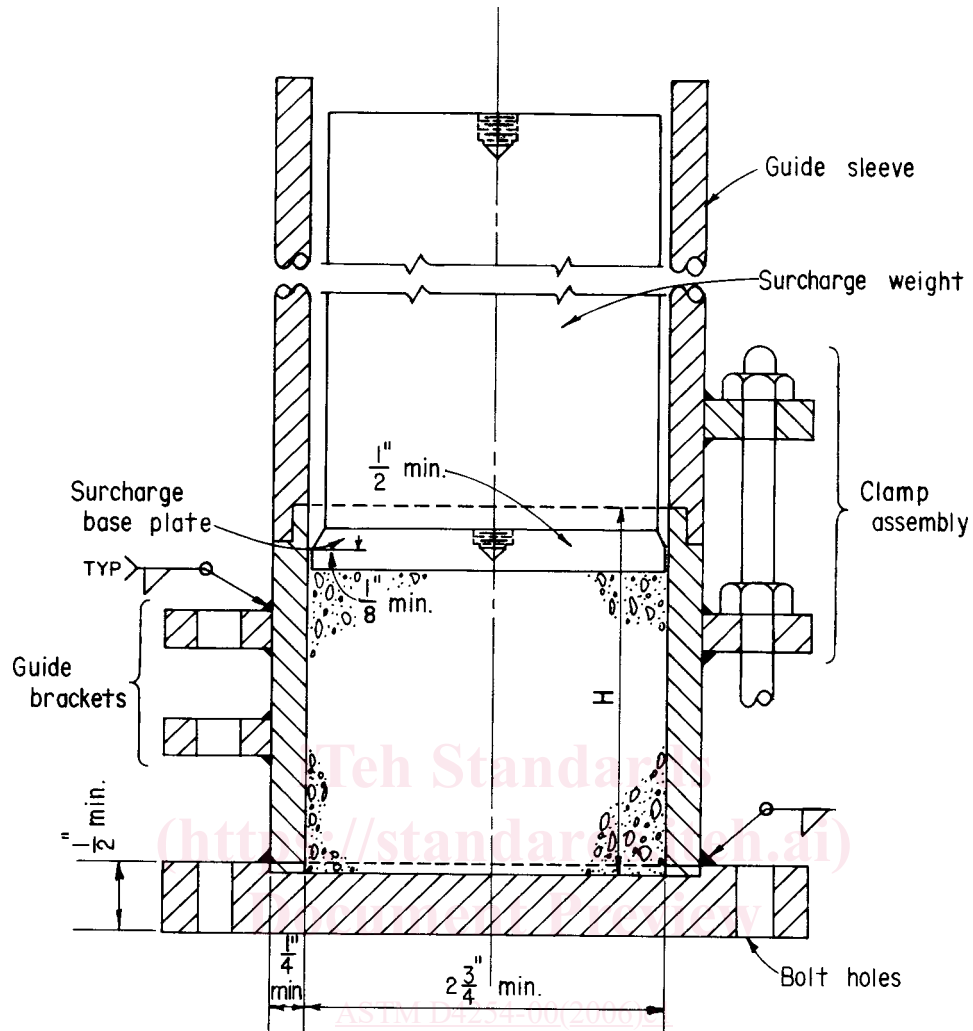

H = (0.7 to 1.3) times diameter

SD	Equivalents
in.	mm
1/8	3.2
1/4	6.4
1/2	13
3/4	70

FIG. 2 Special Cylindrical Metal Molds

7.3 The required size (mass) of the test specimen and mold is a function of the maximum particle size contained in the sample and the particle-size distribution (gradation) of the sample (see Table 1).

7.3.1 Using a visual method or Test Method D 422 (depending upon the complexity of the gradation of the sample and operator experience, determine the percentage of particles retained on the 3-in. (75-mm), 1-1/2-in. (37.5-mm), 3/4-in. (19.0-mm), 3/8-in.

TABLE 1 Required Mass of Specimen

Maximum Size of Soil 100% Partsieleng, in. (mm)	Mass of Specimen Required, kg	Placement Device to be Used in Minimum Density Test	Size of Mold to Be Used, ft ³ (cm ³)
3 (75)	34	shovel or extra large scoop	0.500 (14 200)
1 1/2 (38.1)	34	scoop	0.500 (14 200)
3/4 (19.0)	11	scoop	0.100 (2 830)
3/8 (9.5)	11	pouring device (1-in. (25-mm) dia spout)	0.100 (2 830)
3/8 (9.5)	11	pouring device with 1-in. (25-mm) diameter spout	0.100 (2 830)
No. 4 (4.75) or less	11	pouring device (1/2-in. (13 mm) dia spout)	0.100 (2 830)
No. 4 (4.75) or less	11	pouring device with 1/2-in. (13-mm) diameter spout)	0.100 (2 830)