

---

---

**Road vehicles— FlexRay  
communications system —**

**Part 3:  
Data link layer conformance test  
specification**

*Véhicules routiers — Système de communications FlexRay —*

*Partie 3: Spécification d'essai de conformité de la couche de liaison de données*

Document Preview

[ISO 17458-3:2013](https://standards.iteh.ai/catalog/standards/iso/259ac968-dbd9-4c10-b29f-ab328bf0fca0/iso-17458-3-2013)

<https://standards.iteh.ai/catalog/standards/iso/259ac968-dbd9-4c10-b29f-ab328bf0fca0/iso-17458-3-2013>



iTeh Standards  
(<https://standards.iteh.ai>)  
Document Preview

[ISO 17458-3:2013](https://standards.iteh.ai/catalog/standards/iso/259ac968-dbd9-4c10-b29f-ab328bf0fca0/iso-17458-3-2013)

<https://standards.iteh.ai/catalog/standards/iso/259ac968-dbd9-4c10-b29f-ab328bf0fca0/iso-17458-3-2013>



**COPYRIGHT PROTECTED DOCUMENT**

© ISO 2013

All rights reserved. Unless otherwise specified, no part of this publication may be reproduced or utilized in any form or by any means, electronic or mechanical, including photocopying and microfilm, without permission in writing from either ISO at the address below or ISO's member body in the country of the requester.

ISO copyright office  
Case postale 56 • CH-1211 Geneva 20  
Tel. + 41 22 749 01 11  
Fax + 41 22 749 09 47  
E-mail [copyright@iso.org](mailto:copyright@iso.org)  
Web [www.iso.org](http://www.iso.org)

Published in Switzerland

# Contents

Page

Foreword .....	iv
Introduction.....	v
1 Scope .....	1
2 Normative references .....	1
3 Terms, definitions, symbols and abbreviated terms .....	1
3.1 Terms and definitions .....	1
3.2 Symbols.....	1
3.3 Abbreviated terms .....	2
3.4 Functions.....	4
4 Conventions .....	4
5 Document overview.....	5
6 General .....	6
6.1 Test architecture.....	6
6.2 Test implementation.....	7
6.3 Internal RxDelay .....	9
6.4 Analog delays .....	9
6.5 Accepted deviations.....	10
6.6 Testability requirements .....	11
6.7 Test execution .....	14
7 Conformance test cases .....	16
7.1 General statements and test case structure.....	16
7.2 Receive data.....	23
7.3 CHI.....	125
7.4 Clock synchronisation .....	440
7.5 Wakeup .....	530
7.6 Startup .....	568
7.7 Miscellaneous .....	672
7.8 Optional TT-E feature .....	820
7.9 Preambles .....	846
8 Configuration .....	854
8.1 Basic configuration .....	854
8.2 Standard modifications.....	859
9 Static test cases .....	861
9.1 Electrical interface.....	861
9.2 Protocol parameter.....	861
<b>Annex A (normative) Technical data for the electrical interface of a FlexRay Communication Controller V3.0 .....</b>	<b>862</b>
<b>Annex B (normative) Technical data for the protocol parameter of a FlexRay Communication Controller V3.0 .....</b>	<b>864</b>
<b>Bibliography.....</b>	<b>865</b>

## Foreword

ISO (the International Organization for Standardization) is a worldwide federation of national standards bodies (ISO member bodies). The work of preparing International Standards is normally carried out through ISO technical committees. Each member body interested in a subject for which a technical committee has been established has the right to be represented on that committee. International organizations, governmental and non-governmental, in liaison with ISO, also take part in the work. ISO collaborates closely with the International Electrotechnical Commission (IEC) on all matters of electrotechnical standardization.

International Standards are drafted in accordance with the rules given in the ISO/IEC Directives, Part 2.

The main task of technical committees is to prepare International Standards. Draft International Standards adopted by the technical committees are circulated to the member bodies for voting. Publication as an International Standard requires approval by at least 75 % of the member bodies casting a vote.

Attention is drawn to the possibility that some of the elements of this document may be the subject of patent rights. ISO shall not be held responsible for identifying any or all such patent rights.

ISO 17458-3 was prepared by Technical Committee ISO/TC 22, *Road vehicles*, Subcommittee SC 3, *Electrical and electronic equipment*.

ISO 17458 consists of the following parts, under the general title *Road vehicles — FlexRay communications system*:

- *Part 1: General information and use case definition*
- *Part 2: Data link layer specification*
- *Part 3: Data link layer conformance test specification*
- *Part 4: Electrical physical layer specification*
- *Part 5: Electrical physical layer conformance test specification*

## Introduction

The FlexRay communications system is an automotive focused high speed network and was developed with several main objectives which were defined beyond the capabilities of established standardized bus systems like CAN and some other proprietary bus systems. Some of the basic characteristics of the FlexRay protocol are synchronous and asynchronous frame transfer, guaranteed frame latency and jitter during synchronous transfer, prioritization of frames during asynchronous transfer, single or multi-master clock synchronization, time synchronization across multiple networks, error detection and signalling, and scalable fault tolerance.

The FlexRay communications system is defined for advanced automotive control applications. It serves as a communication infrastructure for future generation high-speed control applications in vehicles by providing:

- A message exchange service that provides deterministic cycle based message transport;
- Synchronization service that provides a common time base to all nodes;
- Start-up service that provides an autonomous start-up procedure;
- Error management service that provides error handling and error signalling;
- Wakeup service that addresses the power management needs.

Since start of development the automotive industry world wide supported the specification development. The FlexRay communications system has been successfully implemented in production vehicles today.

The ISO 17458 series specifies the use cases, the communication protocol and physical layer requirements of an in-vehicle communication network called "FlexRay communications system".

This part of ISO 17458 has been established in order to define the protocol conformance test case requirements.

To achieve this, it is based on the Open Systems Interconnection (OSI) Basic Reference Model specified in ISO/IEC 7498-1 and ISO/IEC 10731, which structures communication systems into seven layers. When mapped on this model, the protocol and physical layer requirements specified by ISO 17458 are broken into:

- Diagnostic services (layer 7), specified in ISO 14229-1 [14], ISO 14229-4 [16];
- Presentation layer (layer 6), vehicle manufacturer specific;
- Session layer services (layer 5), specified in ISO 14229-2 [15];
- Transport layer services (layer 4), specified in ISO 10681-2 [5];
- Network layer services (layer 3), specified in ISO 10681-2 [5];
- Data link layer (layer 2), specified in ISO 17458-2, ISO 17458-3;
- Physical layer (layer 1), specified in ISO 17458-4, ISO 17458-5;

in accordance with Table 1.

**Table 1 — FlexRay communications system specifications applicable to the OSI layers**

Applicability	OSI 7 layers	ISO 17458 FlexRay communications system	Vehicle manufacturer enhanced diagnostics
Seven layer according to ISO 7498-1 and ISO/IEC 10731	Application (layer 7)	vehicle manufacturer specific	ISO 14229-1, ISO 14229-4
	Presentation (layer 6)	vehicle manufacturer specific	vehicle manufacturer specific
	Session (layer 5)	vehicle manufacturer specific	ISO 14229-2
	Transport (layer 4)	vehicle manufacturer specific	ISO 10681-2
	Network (layer 3)	vehicle manufacturer specific	
	Data link (layer 2)	ISO 17458-2, ISO 17458-3	
	Physical (layer 1)	ISO 17458-4, ISO 17458-5	

Table 1 shows ISO 17458 Parts 2 – 5 being the common standards for the OSI layers 1 and 2 for the FlexRay communications system and the vehicle manufacturer enhanced diagnostics.

The FlexRay communications system column shows vehicle manufacturer specific definitions for OSI layers 3 – 7.

The vehicle manufacturer enhanced diagnostics column shows application layer services covered by ISO 14229-4 which have been defined in compliance with diagnostic services established in ISO 14229-1, but are not limited to use only with them. ISO 14229-4 is also compatible with most diagnostic services defined in national standards or vehicle manufacturer's specifications. The presentation layer is defined vehicle manufacturer specific. The session layer services are covered by ISO 14229-2. The transport protocol and network layer services are specified in ISO 10681.

Document Preview

[ISO 17458-3:2013](https://standards.iteh.ai/catalog/standards/iso/259ac968-dbd9-4c10-b29f-ab328bf0fca0/iso-17458-3-2013)

<https://standards.iteh.ai/catalog/standards/iso/259ac968-dbd9-4c10-b29f-ab328bf0fca0/iso-17458-3-2013>

# Road vehicles — FlexRay communications system — Part 3: Data link layer conformance test specification

## 1 Scope

This part of ISO 17458 specifies the FlexRay protocol conformance test. This test verifies the conformance of FlexRay communication controllers with respect to ISO 17458-2.

Some testability requirements are given in 6.2.2.3 and 6.6 and are applicable for FlexRay communication controllers to pass the conformance test

## 2 Normative references

The following referenced documents are indispensable for the application of this document. For dated references, only the edition cited applies. For undated references, the latest edition of the referenced document (including any amendments) applies.

ISO 17458-2, *Road vehicles — FlexRay communications system — Part 2: Data link layer specification*

ISO 17458-4, *Road vehicles — FlexRay communications system — Part 4: Electrical physical layer specification*

## 3 Terms, definitions, symbols and abbreviated terms

### 3.1 Terms and definitions

For the purposes of this document, the terms and definitions defined in ISO 17458-2 and ISO 17458-4 apply.

### 3.2 Symbols

$\Delta$	delta
$\epsilon$	Element, lower-case epsilon
$\xi$	Xsi
$\mu\text{T}$	microtick
$\sigma\text{T}$	<i>gdSampleClockPeriod</i> (= <i>Sampletick</i> )
$t_{\text{RC}}$	modification of cycle length due to calculated rate correction (equal to <i>zRateCorrection</i> , used in figures of "Clock synchronisation")
$t_{\text{OC}}$	modification of cycle length due to calculated offset correction (equal to <i>zOffsetCorrection</i> , used in figures of "Clock synchronisation")

$\varphi_{Rx}$ ,  $\varphi_{Tx}$  analogue delays (see 6.4)

$\xi$ ,  $\xi_{IUT}$  allowed deviation from theoretical results due to LT-IUT jitter (see 6.5)

### 3.3 Abbreviated terms

BC basic configuration

BD bus driver

BSS byte start sequence

CAS collision avoidance symbol

CC communication controller

CE communication element

CHI controller host interface

CHIRP channel idle recognition point

CRC cyclic redundancy code

DC dual channel

DTS dynamic trailing sequence

FES frame end sequence

FIFO first in first out

FPGA field programmable gate array [ISO 17458-3:2013](https://standards.iteh.ai/catalog/standards/iso/259ac968-dbd9-4c10-b29f-ab328bf0fca0/iso-17458-3-2013)

FSS frame start sequence

ID identifier

IP intellectual property

IUT implementation under test

LT lower tester

MT macrotick

MTS media access test symbol

NIT network idle time

NM network management

PE protocol engine

POC protocol operation control

RTL register transfer level



RxD	receive data signal from bus driver
SC	single channel
TE	test execution
TSS	transmission start sequence
TT-D	time triggered distributed
TT-E	time triggered external
TxD	transmit data signal from CC
TxEN	transmit data enable not signal from CC
UT	upper tester
WUDOP	wakeup during operation pattern
WUP	wakeup pattern
WUS	wakeup symbol

**POC states:**

C	<i>POC:config</i>
CSCC	<i>POC:coldstart consistency check</i>
CSCR	<i>POC:coldstart collision resolution</i>
CSG	<i>POC:coldstart gap</i>
CSJ	<i>POC:coldstart join</i>
CSL	<i>POC:coldstart listen</i>
DC	<i>POC:default config</i>
H	<i>POC:halt</i>
ICC	<i>POC:integration consistency check</i>
ICSC	<i>POC:integration coldstart check</i>
IL	<i>POC:integration listen</i>
IS	<i>POC:initialize schedule</i>
NA	<i>POC:normal active</i>
NP	<i>POC:normal passive</i>
R	<i>POC:ready</i>

### 3.4 Functions

TruncateTowardsZero: function returns the integer part of a number without its fractional digits  
(=  $\text{sign}(x) * \text{floor}(|x|)$ )

## 4 Conventions

ISO 17458 are based on the conventions specified in the OSI Service Conventions (ISO/IEC 10731) as they apply for physical and data link layer (protocol).

iTeh Standards  
(<https://standards.iteh.ai>)  
Document Preview

[ISO 17458-3:2013](https://standards.iteh.ai/catalog/standards/iso/259ac968-dbd9-4c10-b29f-ab328bf0fca0/iso-17458-3-2013)

<https://standards.iteh.ai/catalog/standards/iso/259ac968-dbd9-4c10-b29f-ab328bf0fca0/iso-17458-3-2013>

## 5 Document overview

Figure 1 depicts the FlexRay document reference according to OSI model.

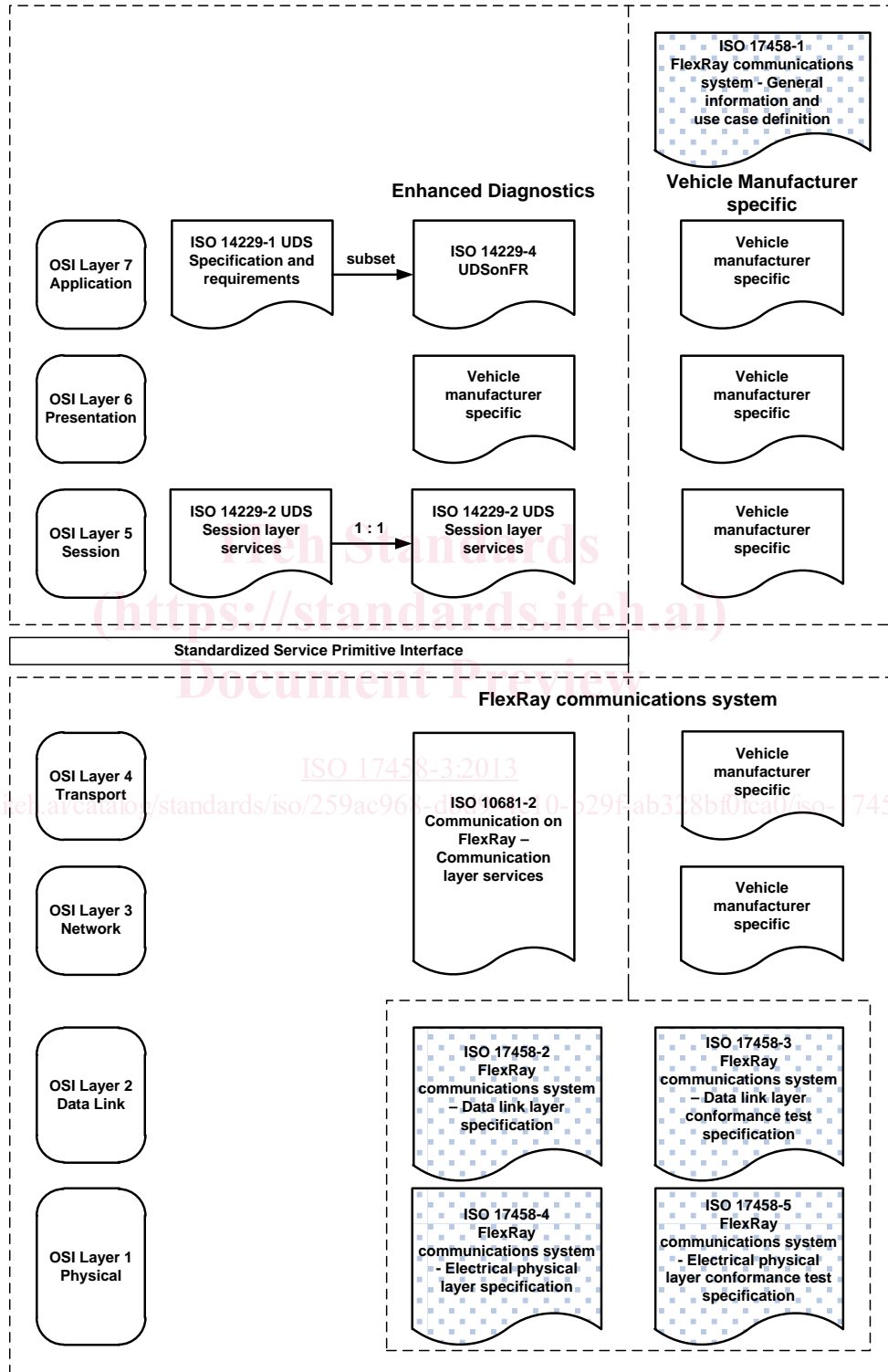

Figure 1 — FlexRay document reference according to OSI model

## 6 General

### 6.1 Test architecture

This part of ISO 17458 is based on a test architecture as shown in Figure 2, which follows the ISO 9646 standard. The implementation under test (IUT) is the FlexRay CC. The upper tester (UT) is connected to the FlexRay controller host interface (CHI) of the IUT and the CHI is device specific. The lower tester (LT) is connected to the FlexRay physical layer interface of the IUT and ISO 17458-4 describes this interface. The test coordination procedure controls the UT and the LT.

In a hardware-based test environment (see 6.2.2), the FlexRay CC can be an “embedded” FlexRay CC meaning that CC is embedded in a microcontroller. In this case, the CHI (i.e., the upper tester interface) is between the embedded FlexRay CC and the microcontroller and in order to get access to the CHI, the upper tester may be partly distributed to the microcontroller.

The test architecture shown in Figure 2 is suitable for testing one FlexRay CC.

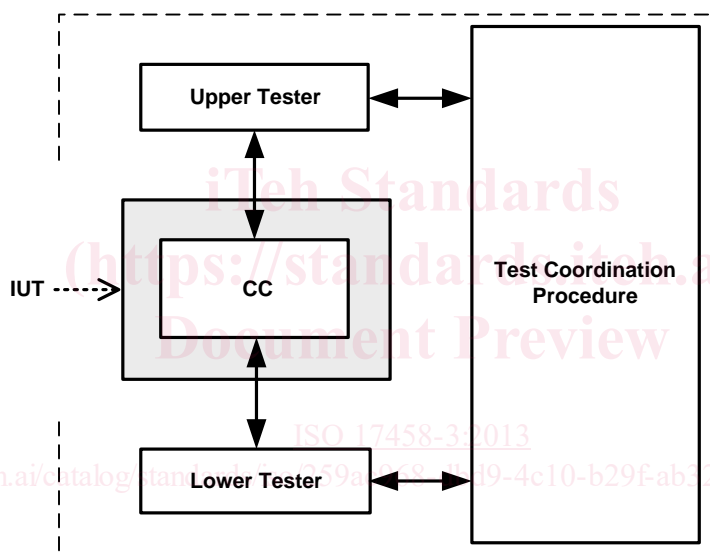

Figure 2 — Standard test architecture

There are some optional test cases in this part of ISO 17458 which tests the optional TT-E feature by using a pair of FlexRay CCs, namely a source CC and a sink CC, which are connected via the time gateway interface. Here, the IUT is the pair of connected FlexRay CCs. To test the TT-E feature, the test architecture as shown in Figure 3 is proposed. The upper tester and lower tester are connected to both FlexRay CCs and the test coordination procedure controls the upper and lower tester.

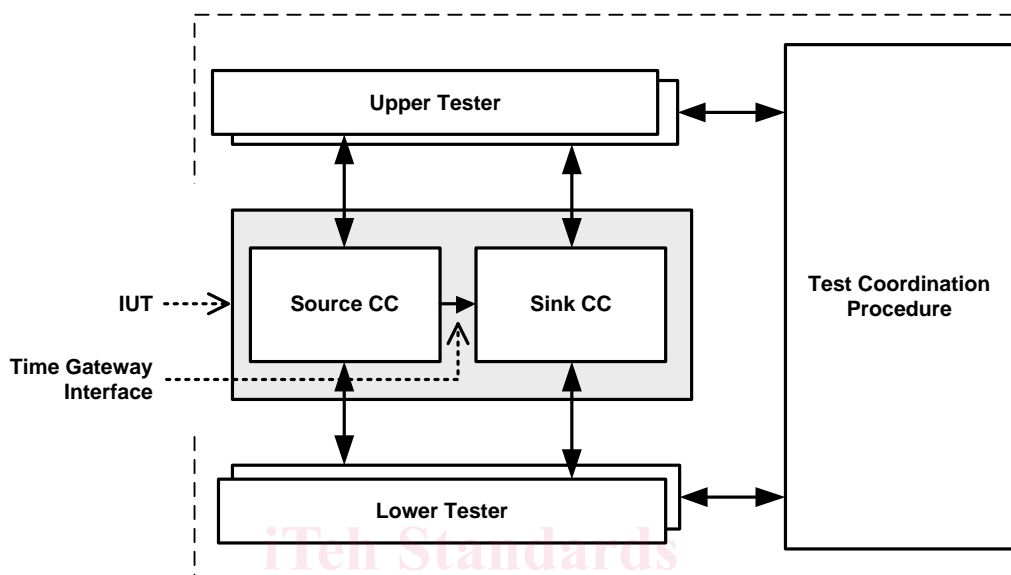

Figure 3 — Test architecture for the TT-E option

## 6.2 Test implementation

<https://standards.iteh.ai/catalog/standards/iso/259ac968-dbd9-4c10-b29f-ab328bf0fca0/iso-17458-3-2013>

<https://standards.iteh.ai/catalog/standards/iso/259ac968-dbd9-4c10-b29f-ab328bf0fca0/iso-17458-3-2013>

### 6.2.1 General

The test cases and the proposed test architecture of this specification can be either implemented in a hardware-based environment or in a simulation-based environment. In the following, both environments are described.

### 6.2.2 Hardware-based test implementation

#### 6.2.2.1 IUT

In a hardware-based test implementation, the IUT is a physical device. The IUT can be either a standalone FlexRay CC, an embedded FlexRay CC, or a FlexRay CC programmed in an FPGA. For testing the optional TT-E feature, the IUT consists of a pair of connected FlexRay CCs.

#### 6.2.2.2 Lower tester

The electrical characteristics of the lower tester shall follow the electrical characteristics of the interface between the FlexRay CC and the FlexRay Bus Driver on the Bus Driver side. This interface is described in ISO 17458-4. The requirements on the lower tester in a hardware-based test environment, including the electrical characteristics, are listed in Table 2. It is not advised to use any extra circuits (e.g., level shifters) between the IUT's FlexRay CC and the lower tester.

Table 2 — Requirements on the lower tester in a hardware-based test environment

Description	Relevant signal	Parameter name used in ISO 17458-4	Min	Max	Unit
Input capacitance	TxD, TxEN	$C\_BDTxD$	-	10	pF
Threshold for detecting logical high	TxD, TxEN	$uBDLogic\_1$	-	60	%
Threshold for detecting logical low	TxD, TxEN	$uBDLogic\_0$	40	-	%
Voltage reference for logical high and low	TxD, TxEN, RxD	$uVDIG$	same as IUT		V
Sample Rate	TxD, TxEN	N/A	160	-	MHz
Asymmetry	RxD	see ISO 17458-4: measured at 50 % $uVDIG$ and 25 pF load	-	2	ns
Sum of rise and fall time @ 15 pF load	RxD	$dBDRxDR15 + dBDRxDF15$	-	13	ns
Difference of rise and fall time @ 15 pF load	RxD	$ dBDRxDR15 - dBDRxDF15 $	-	5	ns
Sum of rise and fall time @ 25 pF load	RxD	$dBDRxDR25 + dBDRxDF25$	-	16,5	ns
Difference of rise and fall time @ 25 pF load	RxD	$ dBDRxDR25 - dBDRxDF25 $	-	5	ns
Frequency of FlexRay clock, provided to IUT	clk	N/A	-	80	MHz
Precision of FlexRay clock, provided to IUT	clk	N/A	-	500	ppm

### 6.2.2.3 Clock synchronisation

Several test cases require the synchronisation between the IUT and the test environment such that random clock deviations can be excluded and the occurrence time of a sample tick can be determined within one sample tick accuracy.

Therefore it is required that the LT provides a clock signal (called "FlexRay clock") to the IUT. The LT shall use the FlexRay clock as a basis for FlexRay bus stimuli of the RxD signal and for sampling the TxD and TxEN signals. The IUT shall also use the FlexRay clock for FlexRay transmission and reception. Existing PLLs in the IUT need to be bypassed or programmed not to multiply. If the IUT uses an own clock source or an active PLL, then there might be the risk of failing some test cases.

Some requirements on the FlexRay clock signal are listed in Table 2. In addition, those frequencies shall be supported, which can be derived from 80 MHz by integer division. The FlexRay clock shall run continuously in order to be able to test embedded FlexRay CCs, where the FlexRay clock signal is also used to for clocking the host microcontroller.

### 6.2.3 Simulation-based test implementation

In a simulation-based test implementation, the IUT is described in a hardware description language typically on register transfer level (RTL), e.g., in SystemVerilog code or VHDL code. The IUT is a FlexRay CC, including message buffers and FIFO. For testing the optional TT-E feature, the IUT consists of a pair of connected FlexRay CCs. The test environment (upper tester, lower tester, and test coordination procedure) and the test cases exist as software only. Executing a test case in a simulation-based test implementation means to load all necessary parts (IUT, test environment, test case) in an RTL simulator and then to run the simulation.

In the simulation-based test implementation, the clocks of the IUT and the LT have no deviation from the nominal frequency and also have no jitter. Therefore, no requirements on the clock synchronisation between the LT and the IUT (as listed in 6.2.2.3 for the hardware-based test implementation) are given for the