



Designation: D 1586 – 08

## Standard Test Method for Standard Penetration Test (SPT) and Split-Barrel Sampling of Soils<sup>1</sup>

This standard is issued under the fixed designation D 1586; the number immediately following the designation indicates the year of original adoption or, in the case of revision, the year of last revision. A number in parentheses indicates the year of last reapproval. A superscript epsilon ( $\epsilon$ ) indicates an editorial change since the last revision or reapproval.

*This standard has been approved for use by agencies of the Department of Defense.*

### 1. Scope\*

1.1 This test method describes the procedure, generally known as the Standard Penetration Test (SPT), for driving a split-barrel sampler to obtain a representative disturbed soil sample for identification purposes, and measure the resistance of the soil to penetration of the sampler. Another method (Test Method D 3550) to drive a split-barrel sampler to obtain a representative soil sample is available but the hammer energy is not standardized.

1.2 Practice D 6066 gives a guide to determining the normalized penetration resistance of sands for energy adjustments of N-value to a constant energy level for evaluating liquefaction potential.

1.3 Test results and identification information are used to estimate subsurface conditions for foundation design.

1.4 Penetration resistance testing is typically performed at 5-foot depth intervals or when a significant change of materials is observed during drilling, unless otherwise specified.

1.5 This test method is limited to use in nonlithified soils and soils whose maximum particle size is approximately less than one-half of the sampler diameter.

1.6 This test method involves use of rotary drilling equipment (Guide D 5783, Practice D 6151). Other drilling and sampling procedures (Guide D 6286, Guide D 6169) are available and may be more appropriate. Considerations for hand driving or shallow sampling without boreholes are not addressed. Subsurface investigations should be recorded in accordance with Practice D 5434. Samples should be preserved and transported in accordance with Practice D 4220 using Group B. Soil samples should be identified by group name and symbol in accordance with Practice D 2488.

1.7 All observed and calculated values shall conform to the guidelines for significant digits and rounding established in Practice D 6026, unless superseded by this test method.

1.8 The values stated in inch-pound units are to be regarded as standard, except as noted below. The values given in

parentheses are mathematical conversions to SI units, which are provided for information only and are not considered standard.

1.8.1 The gravitational system of inch-pound units is used when dealing with inch-pound units. In this system, the pound (lbf) represents a unit of force (weight), while the unit for mass is slugs.

1.9 Penetration resistance measurements often will involve safety planning, administration, and documentation. This test method does not purport to address all aspects of exploration and site safety. *This standard does not purport to address all of the safety concerns, if any, associated with its use. It is the responsibility of the user of this standard to establish appropriate safety and health practices and determine the applicability of regulatory limitations prior to use.* Performance of the test usually involves use of a drill rig; therefore, safety requirements as outlined in applicable safety standards (for example, OSHA regulations,<sup>2</sup> NDA Drilling Safety Guide,<sup>3</sup> drilling safety manuals, and other applicable state and local regulations) must be observed.

### 2. Referenced Documents

#### 2.1 ASTM Standards:<sup>4</sup>

D 653 Terminology Relating to Soil, Rock, and Contained Fluids

D 854 Test Methods for Specific Gravity of Soil Solids by Water Pycnometer

D 1587 Practice for Thin-Walled Tube Sampling of Soils for Geotechnical Purposes

D 2216 Test Methods for Laboratory Determination of Water (Moisture) Content of Soil and Rock by Mass

D 2487 Practice for Classification of Soils for Engineering Purposes (Unified Soil Classification System)

D 2488 Practice for Description and Identification of Soils

<sup>2</sup> Available from Occupational Safety and Health Administration (OSHA), 200 Constitution Ave., NW, Washington, DC 20210, <http://www.osha.gov>.

<sup>3</sup> Available from the National Drilling Association, 3511 Center Rd., Suite 8, Brunswick, OH 44212, <http://www.nda4u.com>.

<sup>4</sup> For referenced ASTM standards, visit the ASTM website, [www.astm.org](http://www.astm.org), or contact ASTM Customer Service at [service@astm.org](mailto:service@astm.org). For *Annual Book of ASTM Standards* volume information, refer to the standard's Document Summary page on the ASTM website.

<sup>1</sup> This method is under the jurisdiction of ASTM Committee D18 on Soil and Rock and is the direct responsibility of Subcommittee D18.02 on Sampling and Related Field Testing for Soil Evaluations.

Current edition approved Feb. 1, 2008. Published March 2008. Originally approved in 1958. Last previous edition approved in 1999 as D 1586 – 99.

\*A Summary of Changes section appears at the end of this standard.

(Visual-Manual Procedure)

- D 3550** Practice for Thick Wall, Ring-Lined, Split Barrel, Drive Sampling of Soils
- D 3740** Practice for Minimum Requirements for Agencies Engaged in the Testing and/or Inspection of Soil and Rock as Used in Engineering Design and Construction
- D 4220** Practices for Preserving and Transporting Soil Samples
- D 4633** Test Method for Energy Measurement for Dynamic Penetrometers
- D 5434** Guide for Field Logging of Subsurface Explorations of Soil and Rock
- D 5783** Guide for Use of Direct Rotary Drilling with Water-Based Drilling Fluid for Geoenvironmental Exploration and the Installation of Subsurface Water-Quality Monitoring Devices
- D 6026** Practice for Using Significant Digits in Geotechnical Data
- D 6066** Practice for Determining the Normalized Penetration Resistance of Sands for Evaluation of Liquefaction Potential
- D 6151** Practice for Using Hollow-Stem Augers for Geotechnical Exploration and Soil Sampling
- D 6169** Guide for Selection of Soil and Rock Sampling Devices Used With Drill Rigs for Environmental Investigations
- D 6286** Guide for Selection of Drilling Methods for Environmental Site Characterization
- D 6913** Test Methods for Particle-Size Distribution (Gradation) of Soils Using Sieve Analysis

### 3. Terminology

3.1 *Definitions:* Definitions of terms included in Terminology **D 653** specific to this practice are:

3.1.1 *cathead, n*—the rotating drum or windlass in the rope-cathead lift system around which the operator wraps a rope to lift and drop the hammer by successively tightening and loosening the rope turns around the drum.

3.1.2 *drill rods, n*—rods used to transmit downward force and torque to the drill bit while drilling a borehole.

3.1.3 *N-value, n*—the blow count representation of the penetration resistance of the soil. The *N*-value, reported in blows per foot, equals the sum of the number of blows (*N*) required to drive the sampler over the depth interval of 6 to 18 in. (150 to 450 mm) (see 7.3).

3.1.4 *Standard Penetration Test (SPT), n*—a test process in the bottom of the borehole where a split-barrel sampler having an inside diameter of either 1-1/2-in. (38.1 mm) or 1-3/8-in. (34.9 mm) (see Note 2) is driven a given distance of 1.0 ft (0.30 m) after a seating interval of 0.5 ft (0.15 m) using a hammer weighing approximately 140-lbf (623-N) falling  $30 \pm 1.0$  in. (0.76 m  $\pm$  0.030 m) for each hammer blow.

3.2 *Definitions of Terms Specific to This Standard:*

3.2.1 *anvil, n*—that portion of the drive-weight assembly which the hammer strikes and through which the hammer energy passes into the drill rods.

3.2.2 *drive weight assembly, n*—an assembly that consists of the hammer, anvil, hammer fall guide system, drill rod attachment system, and any hammer drop system hoisting attachments.

3.2.3 *hammer, n*—that portion of the drive-weight assembly consisting of the  $140 \pm 2$  lbf ( $623 \pm 9$  N) impact weight which is successively lifted and dropped to provide the energy that accomplishes the sampling and penetration.

3.2.4 *hammer drop system, n*—that portion of the drive-weight assembly by which the operator or automatic system accomplishes the lifting and dropping of the hammer to produce the blow.

3.2.5 *hammer fall guide, n*—that part of the drive-weight assembly used to guide the fall of the hammer.

3.2.6 *number of rope turns, n*—the total contact angle between the rope and the cathead at the beginning of the operator's rope slackening to drop the hammer, divided by  $360^\circ$  (see Fig. 1).

3.2.7 *sampling rods, n*—rods that connect the drive-weight assembly to the sampler. Drill rods are often used for this purpose.

### 4. Significance and Use

4.1 This test method provides a disturbed soil sample for moisture content determination, for identification and classification (Practices **D 2487** and **D 2488**) purposes, and for laboratory tests appropriate for soil obtained from a sampler that will produce large shear strain disturbance in the sample such as Test Methods **D 854**, **D 2216**, and **D 6913**. Soil deposits containing gravels, cobbles, or boulders typically result in penetration refusal and damage to the equipment.

4.2 This test method provides a disturbed soil sample for moisture content determination and laboratory identification. Sample quality is generally not suitable for advanced laboratory testing for engineering properties. The process of driving the sampler will cause disturbance of the soil and change the engineering properties. Use of the thin wall tube sampler (Practice **D 1587**) may result in less disturbance in soft soils. Coring techniques may result in less disturbance than SPT sampling for harder soils, but it is not always the case, that is, some cemented soils may become loosened by water action during coring; see Practice **D 6151**, and Guide **D 6169**.

4.3 This test method is used extensively in a great variety of geotechnical exploration projects. Many local correlations and widely published correlations which relate blow count, or *N*-value, and the engineering behavior of earthworks and foundations are available. For evaluating the liquefaction potential of sands during an earthquake event, the *N*-value should be normalized to a standard overburden stress level. Practice **D 6066** provides methods to obtain a record of normalized resistance of sands to the penetration of a standard sampler driven by a standard energy. The penetration resistance is adjusted to drill rod energy ratio of 60 % by using a hammer system with either an estimated energy delivery or directly measuring drill rod stress wave energy using Test Method **D 4633**.

NOTE 1—The reliability of data and interpretations generated by this practice is dependent on the competence of the personnel performing it

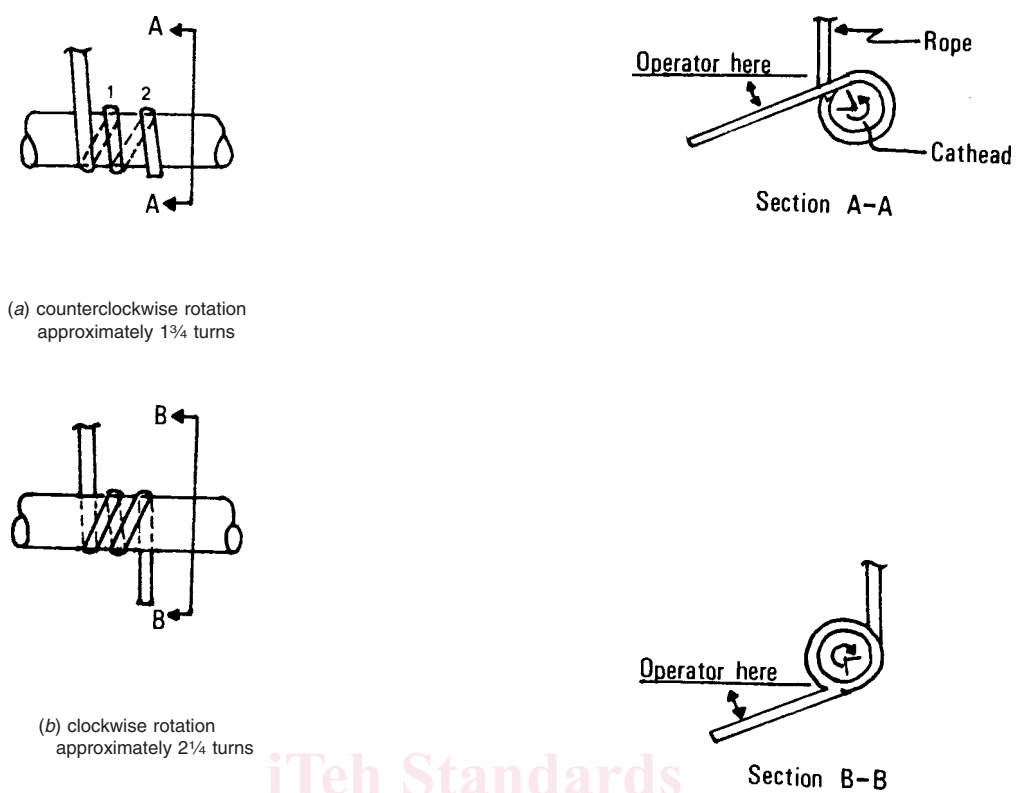

(a) counterclockwise rotation approximately 1 3/4 turns

(b) clockwise rotation approximately 2 1/4 turns

FIG. 1 Definitions of the Number of Rope Turns and the Angle for (a) Counterclockwise Rotation and (b) Clockwise Rotation of the Cathead

and the suitability of the equipment and facilities used. Agencies that meet the criteria of Practice D 3740 generally are considered capable of competent testing. Users of this practice are cautioned that compliance with Practice D 3740 does not assure reliable testing. Reliable testing depends on several factors and Practice D 3740 provides a means of evaluating some of these factors. Practice D 3740 was developed for agencies engaged in the testing, inspection, or both, of soils and rock. As such, it is not totally applicable to agencies performing this practice. Users of this test method should recognize that the framework of Practice D 3740 is appropriate for evaluating the quality of an agency performing this test method. Currently, there is no known qualifying national authority that inspects agencies that perform this test method.

**5. Apparatus**

5.1 *Drilling Equipment*—Any drilling equipment that provides at the time of sampling a suitable borehole before insertion of the sampler and ensures that the penetration test is performed on undisturbed soil shall be acceptable. The following pieces of equipment have proven to be suitable for advancing a borehole in some subsurface conditions:

5.1.1 *Drag, Chopping, and Fishtail Bits*, less than 6 1/2 in. (165 mm) and greater than 2 1/4 in. (57 mm) in diameter may be used in conjunction with open-hole rotary drilling or casing-advancement drilling methods. To avoid disturbance of the underlying soil, bottom discharge bits are not permitted; only side discharge bits are permitted.

5.1.2 *Roller-Cone Bits*, less than 6 1/2 in. (165 mm) and greater than 2 1/4 in. (57 mm) in diameter may be used in conjunction with open-hole rotary drilling or casing-advancement drilling methods if the drilling fluid discharge is deflected.

5.1.3 *Hollow-Stem Continuous Flight Augers*, with or without a center bit assembly, may be used to drill the borehole. The inside diameter of the hollow-stem augers shall be less than 6 1/2 in. (165 mm) and not less than 2 1/4 in. (57 mm).

5.1.4 *Solid, Continuous Flight, Bucket and Hand Augers*, less than 6 1/2 in. (165 mm) and not less than 2 1/4 in. (57 mm) in diameter may be used if the soil on the side of the borehole does not cave onto the sampler or sampling rods during sampling.

5.2 *Sampling Rods*—Flush-joint steel drill rods shall be used to connect the split-barrel sampler to the drive-weight assembly. The sampling rod shall have a stiffness (moment of inertia) equal to or greater than that of parallel wall “A” rod (a steel rod that has an outside diameter of 1-5/8 in. (41.3 mm) and an inside diameter of 1-1/8 in. (28.5 mm)).

5.3 *Split-Barrel Sampler*—The standard sampler dimensions are shown in Fig. 2. The sampler has an outside diameter of 2.00 in. (50.8 mm). The inside diameter of the of the split-barrel (dimension D in Fig. 2) can be either 1 1/2-in. (38.1

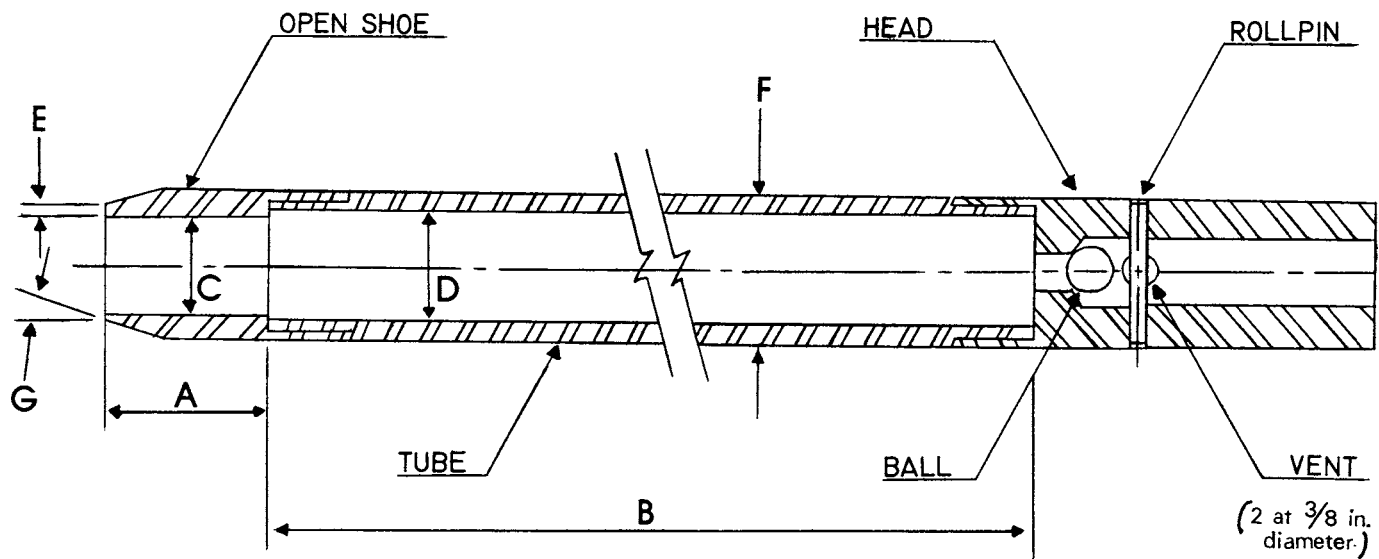

- A = 1.0 to 2.0 in. (25 to 50 mm)
- B = 18.0 to 30.0 in. (0.457 to 0.762 m)
- C = 1.375 ± 0.005 in. (34.93 ± 0.13 mm)
- D = 1.50 ± 0.05 – 0.00 in. (38.1 ± 1.3 – 0.0 mm)
- E = 0.10 ± 0.02 in. (2.54 ± 0.25 mm)
- F = 2.00 ± 0.05 – 0.00 in. (50.8 ± 1.3 – 0.0 mm)
- G = 16.0° to 23.0°

FIG. 2 Split-Barrel Sampler

mm) or 1 3/8-in. (34.9 mm) (see Note 2). A 16-gauge liner can be used inside the 1 1/2-in. (38.1 mm) split barrel sampler. The driving shoe shall be of hardened steel and shall be replaced or repaired when it becomes dented or distorted. The penetrating end of the drive shoe may be slightly rounded. The split-barrel sampler must be equipped with a ball check and vent. Metal or plastic baskets may be used to retain soil samples.

NOTE 2—Both theory and available test data suggest that *N*-values may differ as much as 10 to 30 % between a constant inside diameter sampler and upset wall sampler. If it is necessary to correct for the upset wall sampler refer to Practice D 6066. In North America, it is now common practice to use an upset wall sampler with an inside diameter of 1 1/2 in. At one time, liners were used but practice evolved to use the upset wall sampler without liners. Use of an upset wall sampler allows for use of retainers if needed, reduces inside friction, and improves recovery. Many other countries still use a constant ID split-barrel sampler, which was the original standard and still acceptable within this standard.

#### 5.4 Drive-Weight Assembly:

5.4.1 *Hammer and Anvil*—The hammer shall weigh 140 ± 2 lbf (623 ± 9 N) and shall be a rigid metallic mass. The hammer shall strike the anvil and make steel on steel contact when it is dropped. A hammer fall guide permitting an unimpeded fall shall be used. Fig. 3 shows a schematic of such hammers. Hammers used with the cathead and rope method shall have an unimpeded over lift capacity of at least 4 in. (100 mm). For safety reasons, the use of a hammer assembly with an internal anvil is encouraged as shown in Fig. 3. The total mass of the hammer assembly bearing on the drill rods should not be more than 250 ± 10 lbf (113 ± 5 kg).

NOTE 3—It is suggested that the hammer fall guide be permanently marked to enable the operator or inspector to judge the hammer drop height.

5.4.2 *Hammer Drop System*—Rope-cathead, trip, semi-automatic or automatic hammer drop systems, as shown in Fig. 4 may be used, providing the lifting apparatus will not cause penetration of the sampler while re-engaging and lifting the hammer.

5.5 *Accessory Equipment*—Accessories such as labels, sample containers, data sheets, and groundwater level measuring devices shall be provided in accordance with the requirements of the project and other ASTM standards.

## 6. Drilling Procedure

6.1 The borehole shall be advanced incrementally to permit intermittent or continuous sampling. Test intervals and locations are normally stipulated by the project engineer or geologist. Typically, the intervals selected are 5 ft (1.5 m) or less in homogeneous strata with test and sampling locations at every change of strata. Record the depth of drilling to the nearest 0.1 ft (0.030 m).

6.2 Any drilling procedure that provides a suitably clean and stable borehole before insertion of the sampler and assures that the penetration test is performed on essentially undisturbed soil shall be acceptable. Each of the following procedures has proven to be acceptable for some subsurface conditions. The subsurface conditions anticipated should be considered when selecting the drilling method to be used.

- 6.2.1 Open-hole rotary drilling method.
- 6.2.2 Continuous flight hollow-stem auger method.
- 6.2.3 Wash boring method.
- 6.2.4 Continuous flight solid auger method.

6.3 Several drilling methods produce unacceptable boreholes. The process of jetting through an open tube sampler and

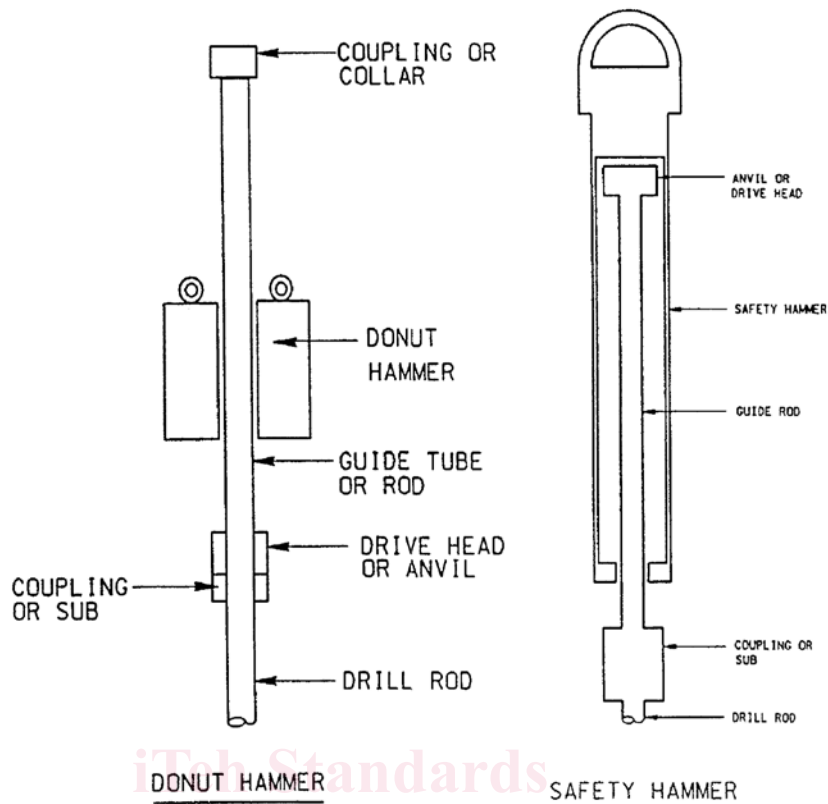

FIG. 3 Schematic Drawing of the Donut Hammer and Safety Hammer

then sampling when the desired depth is reached shall not be permitted. The continuous flight solid auger method shall not be used for advancing the borehole below a water table or below the upper confining bed of a confined non-cohesive stratum that is under artesian pressure. Casing may not be advanced below the sampling elevation prior to sampling. Advancing a borehole with bottom discharge bits is not permissible. It is not permissible to advance the borehole for subsequent insertion of the sampler solely by means of previous sampling with the SPT sampler.

6.4 The drilling fluid level within the borehole or hollow-stem augers shall be maintained at or above the in situ groundwater level at all times during drilling, removal of drill rods, and sampling.

### 7. Sampling and Testing Procedure

7.1 After the borehole has been advanced to the desired sampling elevation and excessive cuttings have been removed, record the cleanout depth to the nearest 0.1 ft (0.030 m), and prepare for the test with the following sequence of operations:

7.1.1 Attach either split-barrel sampler Type A or B to the sampling rods and lower into the borehole. Do not allow the sampler to drop onto the soil to be sampled.

7.1.2 Position the hammer above and attach the anvil to the top of the sampling rods. This may be done before the sampling rods and sampler are lowered into the borehole.

7.1.3 Rest the dead weight of the sampler, rods, anvil, and drive weight on the bottom of the borehole. Record the sampling start depth to the nearest 0.1 ft (0.030 m). Compare

the sampling start depth to the cleanout depth in 7.1. If excessive cuttings are encountered at the bottom of the borehole, remove the sampler and sampling rods from the borehole and remove the cuttings.

7.1.4 Mark the drill rods in three successive 0.5-foot (0.15 m) increments so that the advance of the sampler under the impact of the hammer can be easily observed for each 0.5-foot (0.15 m) increment.

7.2 Drive the sampler with blows from the 140-lbf (623-N) hammer and count the number of blows applied in each 0.5-foot (0.15-m) increment until one of the following occurs:

7.2.1 A total of 50 blows have been applied during any one of the three 0.5-foot (0.15-m) increments described in 7.1.4.

7.2.2 A total of 100 blows have been applied.

7.2.3 There is no observed advance of the sampler during the application of 10 successive blows of the hammer.

7.2.4 The sampler is advanced the complete 1.5 ft. (0.45 m) without the limiting blow counts occurring as described in 7.2.1, 7.2.2, or 7.2.3.

7.2.5 If the sampler sinks under the weight of the hammer, weight of rods, or both, record the length of travel to the nearest 0.1 ft (0.030 m), and drive the sampler through the remainder of the test interval. If the sampler sinks the complete interval, stop the penetration, remove the sampler and sampling rods from the borehole, and advance the borehole through the very soft or very loose materials to the next desired sampling elevation. Record the *N*-value as either weight of hammer, weight of rods, or both.

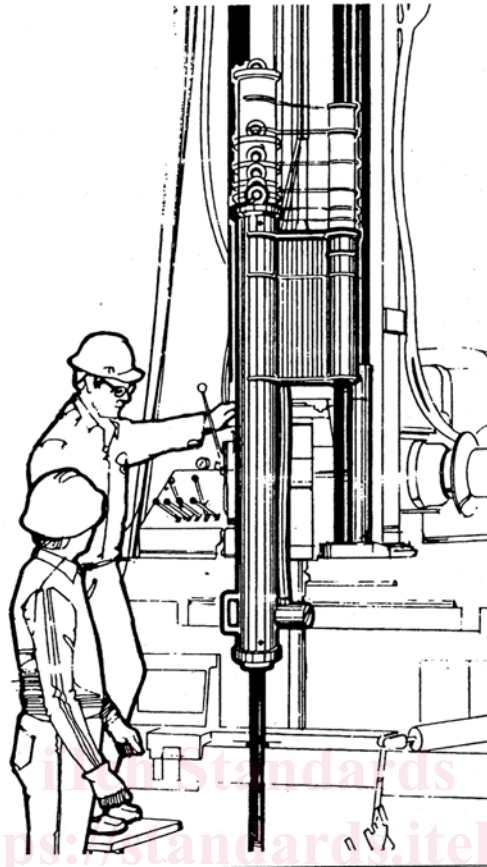

FIG. 4 Automatic Trip Hammer

7.3 Record the number of blows ( $N$ ) required to advance the sampler each 0.5-foot (0.15 m) of penetration or fraction thereof. The first 0.5-foot (0.15 m) is considered to be a seating drive. The sum of the number of blows required for the second and third 0.5-foot (0.15 m) of penetration is termed the “standard penetration resistance,” or the “ $N$ -value.” If the sampler is driven less than 1.5 ft (0.45 m), as permitted in 7.2.1, 7.2.2, or 7.2.3, the number of blows per each complete 0.5-foot (0.15 m) increment and per each partial increment shall be recorded on the boring log. For partial increments, the depth of penetration shall be reported to the nearest 0.1 ft (0.030 m) in addition to the number of blows. If the sampler advances below the bottom of the borehole under the static weight of the drill rods or the weight of the drill rods plus the static weight of the hammer, this information should be noted on the boring log.

7.4 The raising and dropping of the 140-lbf (623-N) hammer shall be accomplished using either of the following two methods. Energy delivered to the drill rod by either method can be measured according to procedures in Test Method D 4633.

7.4.1 *Method A*—By using a trip, automatic, or semi-automatic hammer drop system that lifts the 140-lbf (623-N) hammer and allows it to drop  $30 \pm 1.0$  in. ( $0.76 \text{ m} \pm 0.030 \text{ m}$ ) with limited unimpedance. Drop heights adjustments for automatic and trip hammers should be checked daily and at first indication of variations in performance. Operation of automatic hammers shall be in strict accordance with operations manuals.

7.4.2 *Method B*—By using a cathead to pull a rope attached to the hammer. When the cathead and rope method is used the system and operation shall conform to the following:

7.4.2.1 The cathead shall be essentially free of rust, oil, or grease and have a diameter in the range of 6 to 10 in. (150 to 250 mm).

7.4.2.2 The cathead should be operated at a minimum speed of rotation of 100 RPM.

7.4.2.3 The operator should generally use either 1-3/4 or 2-1/4 rope turns on the cathead, depending upon whether or not the rope comes off the top (1-3/4 turns for counterclockwise rotation) or the bottom (2-1/4 turns for clockwise rotation) of the cathead during the performance of the penetration test, as shown in Fig. 1. It is generally known and accepted that 2-3/4 or more rope turns considerably impedes the fall of the hammer and should not be used to perform the test. The cathead rope should be stiff, relatively dry, clean, and should be replaced when it becomes excessively frayed, oily, limp, or burned.

7.4.2.4 For each hammer blow, a  $30 \pm 1.0$  in. ( $0.76 \text{ m} \pm 0.030 \text{ m}$ ) lift and drop shall be employed by the operator. The operation of pulling and throwing the rope shall be performed rhythmically without holding the rope at the top of the stroke.

NOTE 4—If the hammer drop height is something other than  $30 \pm 1.0$  in. ( $0.76 \text{ m} \pm 0.030 \text{ m}$ ), then record the new drop height. For soils other than sands, there is no known data or research that relates to adjusting the  $N$ -value obtained from different drop heights. Test method D 4633 provides information on making energy measurement for variable drop