



Designation: C882/C882M – 05<sup>ε1</sup>

# Standard Test Method for Bond Strength of Epoxy-Resin Systems Used With Concrete By Slant Shear<sup>1</sup>

This standard is issued under the fixed designation C882/C882M; the number immediately following the designation indicates the year of original adoption or, in the case of revision, the year of last revision. A number in parentheses indicates the year of last reappraisal. A superscript epsilon ( $\epsilon$ ) indicates an editorial change since the last revision or reappraisal.

*This standard has been approved for use by agencies of the Department of Defense.*

<sup>ε1</sup> NOTE—The designation was changed editorially to agree with the existing values statement in the Scope in March 2008.

## 1. Scope

1.1 This test method covers the determination of the bond strength of epoxy-resin-base bonding systems for use with portland-cement concrete. This test method covers bonding hardened concrete to hardened or freshly-mixed concrete.

1.2 The values stated in either inch-pound units or SI units are to be regarded separately as standard. Within the text, the SI units are shown in brackets. The values stated in each system are not exact equivalents; therefore, each system shall be used independently of the other. Combining values from the two systems may result in nonconformance with this test method.

1.3 *This standard does not purport to address all of the safety concerns, if any, associated with its use. It is the responsibility of the user of this standard to establish appropriate safety and health practices and determine the applicability of regulatory limitations prior to use.* A specific hazard statement is given in Section 8.

## 2. Referenced Documents

### 2.1 ASTM Standards:<sup>2</sup>

**C39/C39M** Test Method for Compressive Strength of Cylindrical Concrete Specimens

**C109/C109M** Test Method for Compressive Strength of Hydraulic Cement Mortars (Using 2-in. or [50-mm] Cube Specimens)

**C150** Specification for Portland Cement

<sup>1</sup> This test method is under the jurisdiction of ASTM Committee C09 on Concrete and Concrete Aggregates and is the direct responsibility of Subcommittee C09.25 on Organic Materials for Bonding.

Current edition approved Nov. 1, 2005. Published November 2005. Originally approved in 1978. Last previous edition approved in 1999 as C882 – 99. DOI: 10.1520/C0882\_C0882M-05E01.

<sup>2</sup> For referenced ASTM standards, visit the ASTM website, [www.astm.org](http://www.astm.org), or contact ASTM Customer Service at [service@astm.org](mailto:service@astm.org). For *Annual Book of ASTM Standards* volume information, refer to the standard's Document Summary page on the ASTM website.

**C192/C192M** Practice for Making and Curing Concrete Test Specimens in the Laboratory

**C511** Specification for Mixing Rooms, Moist Cabinets, Moist Rooms, and Water Storage Tanks Used in the Testing of Hydraulic Cements and Concretes

**C617** Practice for Capping Cylindrical Concrete Specimens

**C881/C881M** Specification for Epoxy-Resin-Base Bonding Systems for Concrete

## 3. Terminology

3.1 See Section on Terminology of Specification **C881/C881M**.

## 4. Summary of Test Method

4.1 The bond strength is determined by using the epoxy system to bond together two equal sections of a 3 by 6-in. [75 by 150-mm] portland-cement mortar cylinder, each section of which has a diagonally cast bonding area at a 30° angle from vertical. After suitable curing of the bonding agent, the test is performed by determining the compressive strength of the composite cylinder.

## 5. Significance and Use

5.1 The strength developed by a bonding system that joins two regions of concrete is its most important property.

## 6. Apparatus

6.1 *Apparatus to Mix Portland-Cement Mortar*—This apparatus shall be as described in Test Method **C109/C109M**, except for the sections on specimen molds, tamper, and testing machine.

6.2 *Specimen Molds*—The molds shall be constructed in the form of right cylinders,  $3 \pm \frac{1}{16}$  in. [ $75 \pm 2$  mm] in inside diameter and  $6 \pm \frac{1}{16}$  in. [ $150 \pm 2$  mm] high. All molds shall be either selected or machined so that the maximum range of the differences in each of the dimensions of the group of molds is less than  $\frac{1}{64}$  in. [0.5 mm]. The molds shall be made of metal

not attacked by portland-cement mortar. The side of the mold shall be sufficiently rigid to prevent spreading or warping. The molds shall be made watertight before use. A satisfactory material for this purpose is the paraffin-rosin mixture described in Test Method C109/C109M.

6.3 *Dummy Section*—A dummy section (Fig. 1) shall be machined of a hard material that is not attacked by portland-cement mortar. It shall fit the mold and be equal to half the volume of the cylinder, but at an angle of 30° from the vertical. Additional dummy sections can be made by casting an epoxy-resin mortar against the machined dummy section contained in a specimen mold. Due precautions, such as waxing, shall be taken to prevent the bonding of the epoxy-resin mortar to the machined dummy section or the mold.

6.4 *Tamping Rod*—The tamping rod shall be a round rod of brass or plastic, 3/8 in. [10 mm] in diameter and approximately 12 in. [300 mm] long, having both ends rounded to hemispherical tips.

6.5 *Apparatus for Mixing Epoxy-Resin Bonding System*—A glass, plastic, or metal container of approximately 3 oz. [0.1 L] capacity shall be used to hand-mix the bonding system. A tongue depressor or wooden stick of similar dimensions shall be used as a paddle.

6.6 *Testing Machine*—The testing machine shall be as described in Test Method C39/C39M.

6.7 *Moist Room*—The moist room shall conform to the requirements of Specification C511.

6.8 *Temperature-Conditioning Chambers*— Rooms or chambers in which the temperature is maintained appropriate to the class of the resin system being tested, in accordance with Specification C881/C881M.

## 7. Materials

7.1 Laboratory conditions, materials, proportions, and procedures for mixing the portland-cement mortar shall be in accordance with Test Method C109/C109M. A Type III cement (Specification C150) shall be used.

7.2 Lightly oil the dummy section and the cylinder mold. Position the dummy section in the mold with the slant side up. Place the portland-cement mortar in the mold in three layers of

approximately equal volume. Rod each layer with 25 strokes of the tamping rod. Distribute the strokes uniformly over the section and rod deeply enough to penetrate into any underlying layer. Rod the bottom layer as deeply as possible. Strike off the surface of the top layer with the trowel, and cover the specimen and mold with a glass or metal plate. Cure the mortar half-cylinder in accordance with Practice C192/C192M for at least 28 days. Then dry the half-cylinder in laboratory air for at least 7 days. As an alternative, a complete 3 by 6-in. [75 by 150 mm] cylinder shall be cast and, after cure, may be saw-cut at an angle of 30°.

7.3 A3 by 6-in. [75 by 150-mm] cylinder of the mortar shall have a compressive strength, when tested in accordance with 11.3, of at least 4500 psi [31 MPa] at 28-days age.

## 8. Hazards

8.1 **Warning**—Epoxy resins contain irritants, especially to the skin, eyes, and respiratory system. Persons handling these materials shall use appropriate protective clothing, including rubber or plastic gloves. If an epoxy resin should contact the skin, it shall be removed immediately with a dry cloth or paper towel, and the area of contact shall be washed thoroughly with soap and water. Solvents shall *not* be used, because they carry the irritant into the skin. Cured epoxy resins are innocuous.

## 9. Sampling

9.1 Take samples in accordance with Specification C881/C881M.

## 10. Test Specimens

10.1 Three composite test specimens are required for all Types of resin systems.

10.2 *Conditioning:*

10.2.1 *Types I, III, IV, VI, and VII Systems*—Condition the resin system components, the mortar sections, and all equipment that will contact the resin to the temperatures specified in Specification C881/C881M.

10.2.1.1 Prepare the test specimens and make provision for maintaining them at the appropriate temperature during the entire cure time. Prepare the surface to be bonded by sand-blasting and dry brushing to remove all loose surface material.

10.2.1.2 Use mortar sections and assemblies that have been soaked in water for 24 h. Place the face of the mortar sections to be bonded on an absorbent material for 10 min prior to applying the adhesive. For assembled test specimens, remove all water by shaking. Allow to air dry for 15 min.

10.2.2 *Type II and Type V Systems*—Since Type II and Type V resins are appropriate for use only at temperatures that permit strength gain of the freshly prepared concrete, only the conditioning temperature for a Class C resin, 73 ± 2 °F [23 ± 1 °C], need be provided.

10.3 *Specimen Preparation:*

10.3.1 *Type I, III, IV, VI, and VII, Grade 2 or 3 Systems*—Two mortar sections will be needed for each test specimen. Wrap 4 mil (100 μm) of polyethylene film 6 by 20 in. [150 by 500 mm] around one section of each pair, even with the base and secure with masking tape. Thoroughly mix the components of the bonding system in the proportions recommended by the

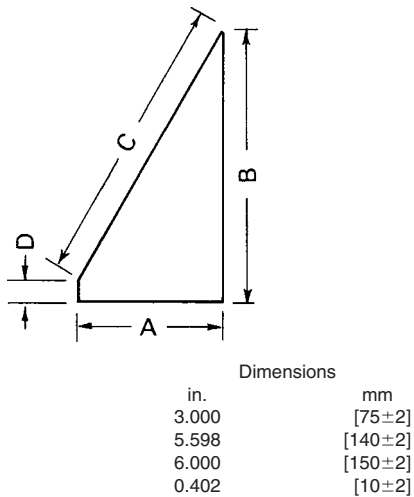

FIG. 1 Dummy Section