

---

---

## Diesel engines — Clamp-mounted fuel injectors, types 7 and 28

*Moteurs à allumage par compression — Porte-injecteurs de combustible complets à fixation par patte, types 7 et 28*

**iTeh STANDARD PREVIEW**  
**(standards.iteh.ai)**

[ISO 2698:2013](https://standards.iteh.ai/catalog/standards/sist/1de92c09-de93-43f2-a252-210a59f5f082/iso-2698-2013)

<https://standards.iteh.ai/catalog/standards/sist/1de92c09-de93-43f2-a252-210a59f5f082/iso-2698-2013>



**iTeh STANDARD PREVIEW**  
**(standards.iteh.ai)**

ISO 2698:2013

<https://standards.iteh.ai/catalog/standards/sist/1de92c09-de93-43f2-a252-210a59f5f082/iso-2698-2013>



**COPYRIGHT PROTECTED DOCUMENT**

© ISO 2013

All rights reserved. Unless otherwise specified, no part of this publication may be reproduced or utilized otherwise in any form or by any means, electronic or mechanical, including photocopying, or posting on the internet or an intranet, without prior written permission. Permission can be requested from either ISO at the address below or ISO's member body in the country of the requester.

ISO copyright office  
Case postale 56 • CH-1211 Geneva 20  
Tel. + 41 22 749 01 11  
Fax + 41 22 749 09 47  
E-mail [copyright@iso.org](mailto:copyright@iso.org)  
Web [www.iso.org](http://www.iso.org)

Published in Switzerland

# Contents

	Page
Foreword .....	iv
<b>1 Scope .....</b>	<b>1</b>
<b>2 Dimensions and tolerances .....</b>	<b>1</b>
2.1 Injectors, types 7 and 28 .....	1
2.2 Clamp location .....	3
2.3 Preferred length <i>L</i> .....	4
<b>3 Other specifications .....</b>	<b>5</b>
<b>Bibliography .....</b>	<b>6</b>

## iTeh STANDARD PREVIEW (standards.iteh.ai)

ISO 2698:2013

<https://standards.iteh.ai/catalog/standards/sist/1de92c09-de93-43f2-a252-210a59f5f082/iso-2698-2013>

## Foreword

ISO (the International Organization for Standardization) is a worldwide federation of national standards bodies (ISO member bodies). The work of preparing International Standards is normally carried out through ISO technical committees. Each member body interested in a subject for which a technical committee has been established has the right to be represented on that committee. International organizations, governmental and non-governmental, in liaison with ISO, also take part in the work. ISO collaborates closely with the International Electrotechnical Commission (IEC) on all matters of electrotechnical standardization.

The procedures used to develop this document and those intended for its further maintenance are described in the ISO/IEC Directives, Part 1. In particular the different approval criteria needed for the different types of ISO documents should be noted. This document was drafted in accordance with the editorial rules of the ISO/IEC Directives, Part 2. [www.iso.org/directives](http://www.iso.org/directives)

Attention is drawn to the possibility that some of the elements of this document may be the subject of patent rights. ISO shall not be held responsible for identifying any or all such patent rights. Details of any patent rights identified during the development of the document will be in the Introduction and/or on the ISO list of patent declarations received. [www.iso.org/patents](http://www.iso.org/patents)

Any trade name used in this document is information given for the convenience of users and does not constitute an endorsement.

The committee responsible for this document is ISO/TC 22, *Road vehicles*, Subcommittee SC 7, *Injection equipment and filters for use on road vehicles*.

This third edition cancels and replaces the second edition (ISO 2698:1993), which has been technically revised.

ISO 2698:2013  
<https://standards.iteh.ai/catalog/standards/sist/1de92c09-de93-43f2-a252-210a59f5f082/iso-2698-2013>

# Diesel engines — Clamp-mounted fuel injectors, types 7 and 28

## 1 Scope

This International Standard specifies dimensions necessary for the mounting of fuel injectors in diesel (compression-ignition) engines.

The location of the fuel inlet and leak-off connections, and the dimensions of the clamp are not defined since they vary according to the particular application.

This International Standard applies to clamp-mounted injectors of types 7 and 28 made of an integral nozzle and nozzle holder design with a 9,5 mm (nominal) injector shank diameter.

## 2 Dimensions and tolerances

### 2.1 Injectors, types 7 and 28

Dimensions and tolerances of injectors of types 7 and 28 are given in [Figures 1](#) and [2](#), respectively.

iTeh STANDARD PREVIEW  
(standards.iteh.ai)

[ISO 2698:2013](#)

<https://standards.iteh.ai/catalog/standards/sist/1de92c09-de93-43f2-a252-210a59f5f082/iso-2698-2013>

Dimensions in millimetres  
Surface roughness in micrometres

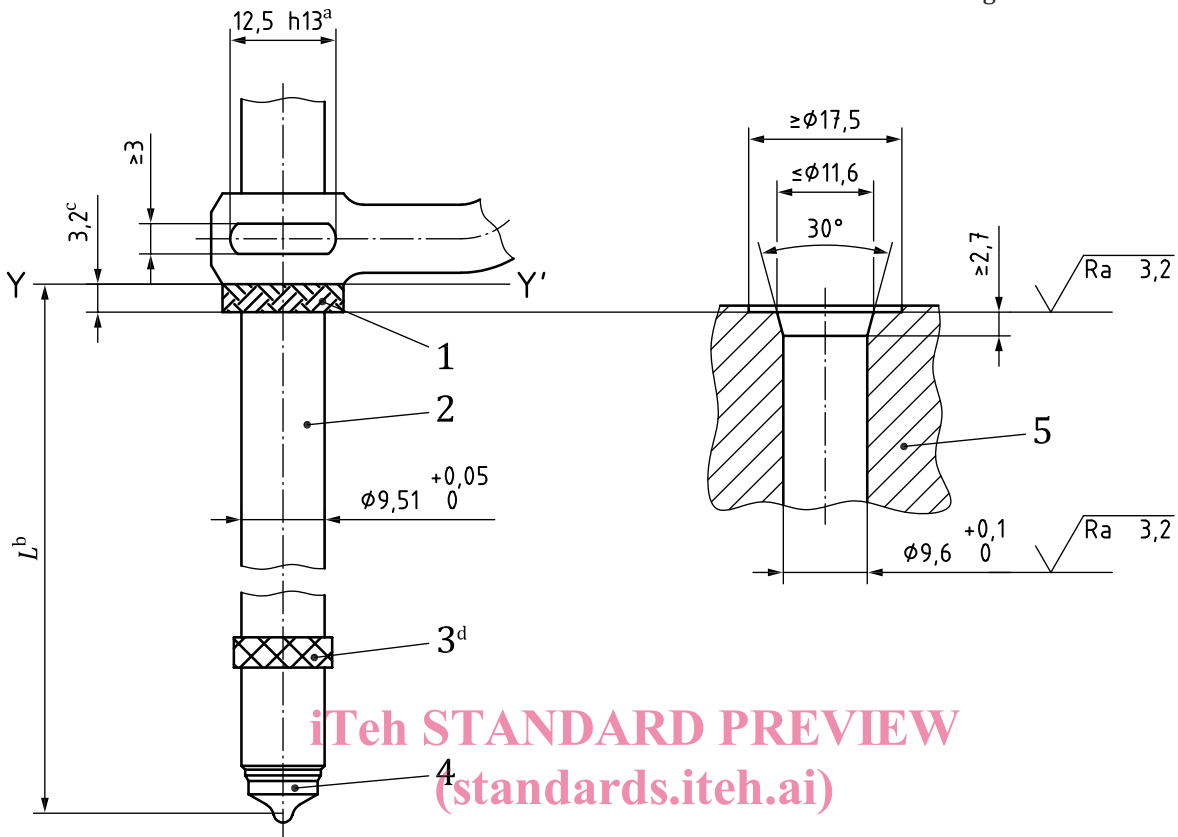

iTeh STANDARD PREVIEW  
(standards.iteh.ai)

**Key**

- 1 sealing washer
- 2 nozzle holder
- 3 seal
- 4 nozzle
- 5 engine

a These flats are optional.

b See 2.3.

c With commercial tolerances (before compression).

d The outer diameter of the seal shall be chosen such that it provides appropriate sealing with the injector bore.

**Figure 1 — Clamp-mounted injector, type 7**

ISO 2698:2013

<https://standards.iteh.ai/catalog/standards/sist/1de92c09-de93-43f2-a252-210a59f5f082/iso-2698-2013>



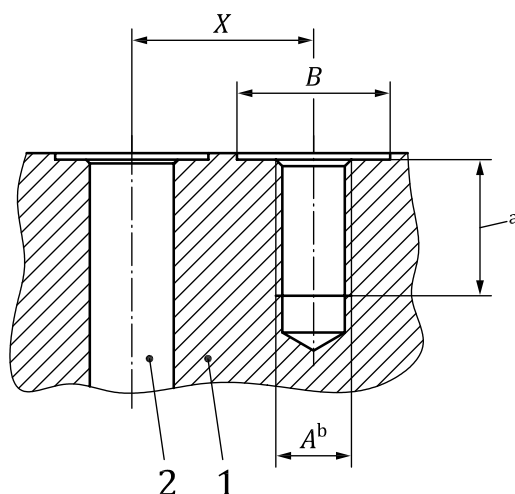

**Key**

- 1 engine
- 2 injector bore
- a Minimum length as required.
- b Clamp fastener thread.

Figure 3 — Clamp location for injectors, types 7 and 28

(standards.iteh.ai)

ISO 2698:2013

[https://standards.iteh.ai/catalog/standards/sist/1de92c09-de93-43f2-a252-](https://standards.iteh.ai/catalog/standards/sist/1de92c09-de93-43f2-a252-210a59f5f082/iso-2698-2013)

Table 1 — Injector type X, A and B

Dimensions in millimetres

Injector type	X ±0,3	A <sup>a</sup> nom.	Ø B min.
7 and 28	18,4	M8 x 1,25	15,8
	25	M10 x 1,5	16,9

<sup>a</sup> For fasteners of property class 9,8.

**2.3 Preferred length L**

The length, *L*, determines the distance between the reference plane YY' and the point of intersection of the injection holes axes with the injector axis (see Figures 1 and 2); it varies with the application, i.e. depending on the cylinder head design.

The dimensions and tolerances for the preferred length, *L*, are given in Table 2.



**Table 2 — Injector type *L***

Dimensions in millimetres

<b>Injector type</b>	<i>L</i> ±0,3
7 and 28	81,4

### 3 Other specifications

Dimensions and requirements not given in this International Standard are left to the discretion of the manufacturer.

**iTeh STANDARD PREVIEW**  
**(standards.iteh.ai)**

ISO 2698:2013

<https://standards.iteh.ai/catalog/standards/sist/1de92c09-de93-43f2-a252-210a59f5f082/iso-2698-2013>