**Tools for pressing — Gas springs —
Part 3:
Gas spring with increased spring force
and compact built height**

Outillage de presse — Ressorts à gaz —

*Partie 3: Ressorts à gaz à force accrue à faible encombrement en
hauteur*
(standards.iteh.ai)

[ISO 11901-3:2014](https://standards.iteh.ai/catalog/standards/sist/4c3bd73d-1df2-4b3d-b7f9-f566fa923086/iso-11901-3-2014)

<https://standards.iteh.ai/catalog/standards/sist/4c3bd73d-1df2-4b3d-b7f9-f566fa923086/iso-11901-3-2014>



iTeh STANDARD PREVIEW
(standards.iteh.ai)

[ISO 11901-3:2014](https://standards.iteh.ai/catalog/standards/sist/4c3bd73d-1df2-4b3d-b7f9-f566fa923086/iso-11901-3-2014)

<https://standards.iteh.ai/catalog/standards/sist/4c3bd73d-1df2-4b3d-b7f9-f566fa923086/iso-11901-3-2014>



COPYRIGHT PROTECTED DOCUMENT

© ISO 2014

All rights reserved. Unless otherwise specified, no part of this publication may be reproduced or utilized otherwise in any form or by any means, electronic or mechanical, including photocopying, or posting on the internet or an intranet, without prior written permission. Permission can be requested from either ISO at the address below or ISO's member body in the country of the requester.

ISO copyright office
Case postale 56 • CH-1211 Geneva 20
Tel. + 41 22 749 01 11
Fax + 41 22 749 09 47
E-mail copyright@iso.org
Web www.iso.org

Published in Switzerland

Contents

	Page
Foreword.....	iv
Introduction.....	v
1 Scope.....	1
2 Normative references.....	1
3 Description and terminology.....	1
4 Interchangeability dimensions and characteristics.....	2
4.1 General nominal specifications.....	2
4.2 Gas springs of type 1 700 and 3 200.....	3
4.3 Gas springs of type 3 500 and 15 000.....	3
4.4 Gas springs of type 24 000 to 200 000.....	3
5 Filling pressure.....	10
6 Marking.....	11
7 Technical delivery conditions.....	11
8 Designation.....	11
Bibliography.....	13

iTeh STANDARD PREVIEW (standards.iteh.ai)

[ISO 11901-3:2014](https://standards.iteh.ai/catalog/standards/sist/4c3bd73d-1df2-4b3d-b7f9-f566fa923086/iso-11901-3-2014)

<https://standards.iteh.ai/catalog/standards/sist/4c3bd73d-1df2-4b3d-b7f9-f566fa923086/iso-11901-3-2014>

Foreword

ISO (the International Organization for Standardization) is a worldwide federation of national standards bodies (ISO member bodies). The work of preparing International Standards is normally carried out through ISO technical committees. Each member body interested in a subject for which a technical committee has been established has the right to be represented on that committee. International organizations, governmental and non-governmental, in liaison with ISO, also take part in the work. ISO collaborates closely with the International Electrotechnical Commission (IEC) on all matters of electrotechnical standardization.

The procedures used to develop this document and those intended for its further maintenance are described in the ISO/IEC Directives, Part 1. In particular the different approval criteria needed for the different types of ISO documents should be noted. This document was drafted in accordance with the editorial rules of the ISO/IEC Directives, Part 2 (see www.iso.org/directives).

Attention is drawn to the possibility that some of the elements of this document may be the subject of patent rights. ISO shall not be held responsible for identifying any or all such patent rights. Details of any patent rights identified during the development of the document will be in the Introduction and/or on the ISO list of patent declarations received (see www.iso.org/patents).

Any trade name used in this document is information given for the convenience of users and does not constitute an endorsement.

For an explanation on the meaning of ISO specific terms and expressions related to conformity assessment, as well as information about ISO's adherence to the WTO principles in the Technical Barriers to Trade (TBT) see the following URL: [Foreword - Supplementary information](#)

The committee responsible for this document is ISO/TC 29, *Small tools*, Subcommittee SC 8, *Tools for pressing and moulding*.

ISO 11901 consists of the following parts, under the general title *Tools for pressing — Gas springs*:

- *Part 1: General specifications*
- *Part 2: Specification of accessories*
- *Part 3: Gas spring with increased spring force and compact built height*
- *Part 4: Gas springs with increased spring force and same built height*

Introduction

The attention of the user of ISO 11901 is drawn to the fact that gas springs will have to conform to the national regulations of the user country.

iTeh STANDARD PREVIEW
(standards.iteh.ai)

[ISO 11901-3:2014](https://standards.iteh.ai/catalog/standards/sist/4c3bd73d-1df2-4b3d-b7f9-f566fa923086/iso-11901-3-2014)

<https://standards.iteh.ai/catalog/standards/sist/4c3bd73d-1df2-4b3d-b7f9-f566fa923086/iso-11901-3-2014>

iTeh STANDARD PREVIEW
(standards.iteh.ai)

[ISO 11901-3:2014](#)

<https://standards.iteh.ai/catalog/standards/sist/4c3bd73d-1df2-4b3d-b7f9-f566fa923086/iso-11901-3-2014>

Tools for pressing — Gas springs —

Part 3: Gas spring with increased spring force and compact built height

1 Scope

This part of ISO 11901 specifies the dimensions (in millimetres), nominal initial forces and types of gas springs.

It is applicable to gas springs with increased spring force and compact built height of type 1 700 to 200 000, pressurized with nitrogen with a nominal initial force of between $1\,700\text{ N} \pm 5\%$ and $200\,000\text{ N} \pm 5\%$, for use in press tools.

It also specifies marking, technical delivery conditions and designation.

NOTE Specifications of mounting accessories for gas springs are given in ISO 11901-2.

2 Normative references

The following documents, in whole or in part, are normatively referenced in this document and are indispensable for its application. For dated references, only the edition cited applies. For undated references, the latest edition of the referenced document (including any amendments) applies

ISO 7-1, *Pipe threads where pressure-tight joints are made on the threads — Part 1: Dimensions, tolerances and designation*

ISO 2768-1, *General tolerances — Part 1: Tolerances for linear and angular dimensions without individual tolerance indications*

3 Description and terminology

See [Figure 1](#).

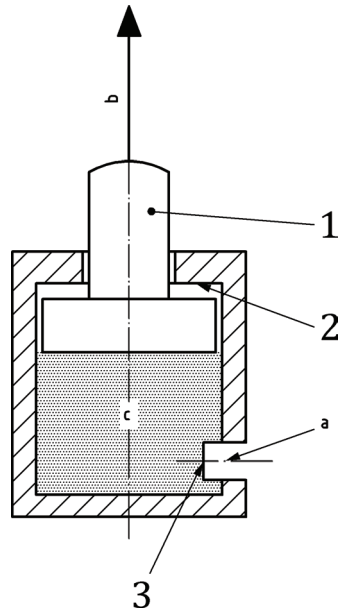

- Key**
- 1 rod
 - 2 positive stop
 - 3 valve
 - a Pressure filling inlet.
 - b Force.
 - c Nitrogen.

iTeh STANDARD PREVIEW
(standards.iteh.ai)

ISO 11901-3:2014
<https://standards.iteh.ai/catalog/standards/sist/50505073d-1d2-4b3d-b79-f566fa923086/iso-11901-3-2014>
Figure 1 – Terminology

The gas spring is an autonomous spring pressurized with nitrogen.

At rest position, the rod is pushed out.

This gas spring feature has a gas inlet for pressurization or depressurization. The inlet is located on the casing or on the bottom and is capped.

The pressure filling inlet of gas springs of type of at least 42 000 includes a pipe thread ISO 7 - Rp 1/8 in accordance with ISO 7-1, and the pressure filling inlet of gas springs of type less than 42 000 includes an M6 thread.

4 Interchangeability dimensions and characteristics

4.1 General nominal specifications

See [Table 1](#).

Table 1 — General nominal specifications

Type	Nominal initial force N		Maximum filling pressure MPa	End of stroke nomi- nal force increase coefficient
1 700	1 700	±5 %	18	1,6
3 200	3 200			1,6
3 500	3 500			1,5
5 000	5 000		15	1,5
7 500	7 500			1,6
10 000	10 000			1,6
15 000	15 000			1,6
24 000	24 000			1,6
42 000	42 000			1,6
66 000	66 000			1,5
95 000	95 000			1,5
200 000	200 000			1,5

4.2 Gas springs of type 1 700 and 3 200

See [Figure 2](#) and [Table 2](#).

4.3 Gas springs of type 3 500 and 15 000

See [Figures 3](#) and [5](#) and [Tables 3](#) and [4](#). [ISO 11901-3:2014](#)

[https://standards.iteh.ai/catalog/standards/sist/4c3bd73d-1df2-4b3d-b7f9-](https://standards.iteh.ai/catalog/standards/sist/4c3bd73d-1df2-4b3d-b7f9-566fa923086/iso-11901-3-2014)

4.4 Gas springs of type 24 000 to 200 000

See [Figures 4](#) and [5](#) and [Tables 3](#) and [4](#).

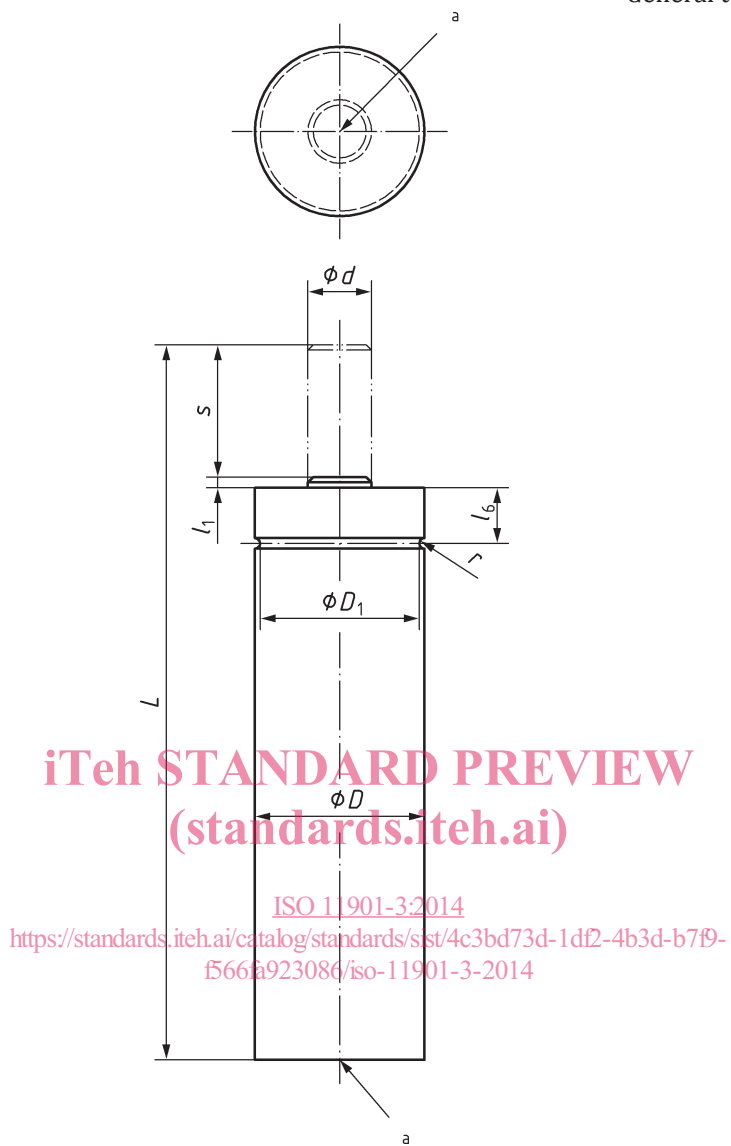

iTeh STANDARD PREVIEW
(standards.iteh.ai)

ISO 11901-3:2014

<https://standards.iteh.ai/catalog/standards/sst/4c3bd73d-1df2-4b3d-b7f9-f566a923086/iso-11901-3-2014>

a Pressure filling inlet.

Figure 2 — Gas springs of type 1 700 and 3 200

Table 2 — Dimensions of gas springs of type 1 700 and 3 200 — Maximum filling pressure 18 MPa

Dimensions in millimetres

Type	Nominal stroke <i>s</i>	<i>L</i> ±0,25	<i>l</i> ₁ $\begin{matrix} +1 \\ 0 \end{matrix}$	<i>l</i> ₆ $\begin{matrix} +1 \\ 0 \end{matrix}$	<i>r</i>	<i>d</i>	<i>D</i> ±0,3	<i>D</i> ₁ $\begin{matrix} 0 \\ -0,1 \end{matrix}$
1 700	10	50	1	16	1	11	19	17
	15	60						
	25	80						
	38	106						
	50	130						
	63	156						
	80	195						
	100	235						
125	285							
3 200	10	50	1	16	1	15	25	23
	15	60						
	25	80						
	38	106						
	50	130						
	63	156						
	80	195						
	100	235						
125	285							

ITeH STANDARD PREVIEW
(standards.iteh.ai)

ISO 11901-3:2014

<http://standards.iteh.ai/catalog/standards/sist/4c3bd73d-1df2-4b3d-b7f9-f566fa923086/iso-11901-3-2014>