



SLOVENSKI STANDARD
oSIST prEN ISO 8130-1:2018
01-junij-2018

**Praškasti premazi - 1. del: Ugotavljanje porazdelitve velikosti delcev s sejanjem
(ISO/DIS 8130-1:2018)**

Coating powders - Part 1: Determination of particle size distribution by sieving (ISO/DIS 8130-1:2018)

Pulverlacke - Teil 1: Bestimmung der Teilchengrößenverteilung durch Sieben (ISO/DIS 8130-1:2018)

Poudres pour revêtement - Partie 1: Détermination de la distribution granulométrique par tamisage (ISO/DIS 8130-1:2018)

Ta slovenski standard je istoveten z: prEN ISO 8130-1

ICS:

87.040 Barve in laki Paints and varnishes

oSIST prEN ISO 8130-1:2018 en,fr,de

DRAFT INTERNATIONAL STANDARD

ISO/DIS 8130-1

ISO/TC 35/SC 9

Secretariat: BSI

Voting begins on:
2018-04-03Voting terminates on:
2018-06-26

Coating powders —

Part 1: Determination of particle size distribution by sieving

*Poudres pour revêtement —**Partie 1: Détermination de la granulométrie par tamisage*

ICS: 87.040

iTeh STANDARD PREVIEW
(standards.iteh.ai)

SIST EN ISO 8130-1:2019

<https://standards.iteh.ai/catalog/standards/sist/a13d3fa7-b361-4922-8aa8-8800074bc713/sist-en-iso-8130-1-2019>

THIS DOCUMENT IS A DRAFT CIRCULATED FOR COMMENT AND APPROVAL. IT IS THEREFORE SUBJECT TO CHANGE AND MAY NOT BE REFERRED TO AS AN INTERNATIONAL STANDARD UNTIL PUBLISHED AS SUCH.

IN ADDITION TO THEIR EVALUATION AS BEING ACCEPTABLE FOR INDUSTRIAL, TECHNOLOGICAL, COMMERCIAL AND USER PURPOSES, DRAFT INTERNATIONAL STANDARDS MAY ON OCCASION HAVE TO BE CONSIDERED IN THE LIGHT OF THEIR POTENTIAL TO BECOME STANDARDS TO WHICH REFERENCE MAY BE MADE IN NATIONAL REGULATIONS.

RECIPIENTS OF THIS DRAFT ARE INVITED TO SUBMIT, WITH THEIR COMMENTS, NOTIFICATION OF ANY RELEVANT PATENT RIGHTS OF WHICH THEY ARE AWARE AND TO PROVIDE SUPPORTING DOCUMENTATION.

This document is circulated as received from the committee secretariat.

ISO/CEN PARALLEL PROCESSING



Reference number
ISO/DIS 8130-1:2018(E)

© ISO 2018

iTeh STANDARD PREVIEW (standards.iteh.ai)

SIST EN ISO 8130-1:2019

<https://standards.iteh.ai/catalog/standards/sist/a13d3fa7-b361-4922-8aa8-8800074bc713/sist-en-iso-8130-1-2019>



COPYRIGHT PROTECTED DOCUMENT

© ISO 2018

All rights reserved. Unless otherwise specified, or required in the context of its implementation, no part of this publication may be reproduced or utilized otherwise in any form or by any means, electronic or mechanical, including photocopying, or posting on the internet or an intranet, without prior written permission. Permission can be requested from either ISO at the address below or ISO's member body in the country of the requester.

ISO copyright office
CP 401 • Ch. de Blandonnet 8
CH-1214 Vernier, Geneva, Switzerland
Tel. +41 22 749 01 11
Fax +41 22 749 09 47
copyright@iso.org
www.iso.org

Published in Switzerland

Contents

	Page
Foreword	iv
1 Scope	1
2 Normative references	1
3 Terms and definitions	1
4 Principle	2
5 Apparatus	2
6 Sampling	4
7 Choice of sieving method and sieve selectivity	4
8 Preparation of the test sieve	5
9 Procedure	5
9.1 Number of determinations	5
9.2 Manual sieving (with mesh sizes greater than 100 µm)	5
9.3 Machine sieving using an air-jet sieve apparatus	5
9.4 Machine sieving using vibration mechanism	6
10 Expression of results	6
11 Precision	7
12 Test report	7
Annex A (normative) Nominal sizes of test sieves	8
Bibliography	9

SIST EN ISO 8130-1:2019

<https://standards.iteh.ai/catalog/standards/sist/a13d3fa7-b361-4922-8aa8-8800074bc713/sist-en-iso-8130-1-2019>

ISO/DIS 8130-1:2018(E)

Foreword

ISO (the International Organization for Standardization) is a worldwide federation of national standards bodies (ISO member bodies). The work of preparing International Standards is normally carried out through ISO technical committees. Each member body interested in a subject for which a technical committee has been established has the right to be represented on that committee. International organizations, governmental and non-governmental, in liaison with ISO, also take part in the work. ISO collaborates closely with the International Electrotechnical Commission (IEC) on all matters of electrotechnical standardization.

The procedures used to develop this document and those intended for its further maintenance are described in the ISO/IEC Directives, Part 1. In particular the different approval criteria needed for the different types of ISO documents should be noted. This document was drafted in accordance with the editorial rules of the ISO/IEC Directives, Part 2 (see www.iso.org/directives).

Attention is drawn to the possibility that some of the elements of this document may be the subject of patent rights. ISO shall not be held responsible for identifying any or all such patent rights. Details of any patent rights identified during the development of the document will be in the Introduction and/or on the ISO list of patent declarations received (see www.iso.org/patents).

Any trade name used in this document is information given for the convenience of users and does not constitute an endorsement.

For an explanation on the voluntary nature of standards, the meaning of ISO specific terms and expressions related to conformity assessment, as well as information about ISO's adherence to the World Trade Organization (WTO) principles in the Technical Barriers to Trade (TBT) see the following URL: www.iso.org/iso/foreword.html.

This document was prepared by Technical Committee ISO/TC 35, *Paints and varnishes*, Subcommittee SC 9, *General test methods for paints and varnishes*.

This second edition cancels and replaces the first edition (ISO 8130-1:1992), which has been technically revised.

The main changes compared to the previous edition are as follows:

- The title of the standard was changed from particle size distribution to particle size;
- a terms and definitions clause has been added;
- a principle clause has been added;
- manual sieving was added as an alternative method;
- the text has been editorially revised and the normative references have been updated.

A list of all parts in the ISO 8130- series can be found on the ISO website.

Coating powders —

Part 1:

Determination of particle size distribution by sieving

1 Scope

This part of ISO 8130 specifies a method for the determination of the particle size of coating powders by sieve analysis. Particle size distributions with a maximum of less than 100 µm should be determined by laser diffraction (see ISO 8130-13). This method is used especially for determining the oversize material or for the presence of contamination and may be used as a quality control procedure (“go”/“no go” test) by checking the amount of powder retained on a single sieve.

The following particle sizes are typical for coating powders, however the particle size can deviate depending on the application:

- thin-film technology: 1 µm to 63 µm
- electrostatic coating: 10 µm to 200 µm
- fluidizing-bed method: 100 µm and above

NOTE Sieves with a mesh size smaller than 32 µm are not practical and are likely to become blind during use.

2 Normative references

The following documents are referred to in the text in such a way that some or all of their content constitutes requirements of this document. For dated references, only the edition cited applies. For undated references, the latest edition of the referenced document (including any amendments) applies.

ISO 565:1990, *Test sieves — Metal wire cloth, perforated metal plate and electroformed sheet — Nominal sizes of openings*

ISO 3310-1, *Test sieves — Technical requirements and testing — Part 1: Test sieves of metal wire cloth*

ISO 3310-2, *Test sieves — Technical requirements and testing — Part 2: Test sieves of perforated metal plate*

ISO 8130-14, *Coating powders — Part 14: Terminology*

ISO 15528, *Paints, varnishes and raw materials for paints and varnishes — Sampling*

3 Terms and definitions

For the purposes of this document, the specific terms and definitions given in ISO 8130-14 apply.

ISO and IEC maintain terminological databases for use in standardization at the following addresses:

- IEC Electropedia: available at <http://www.electropedia.org/>
- ISO Online browsing platform: available at <http://www.iso.org/obp>

ISO/DIS 8130-1:2018(E)

4 Principle

A weighed amount of the coating powder is separated into fractions by one or more sieves and the mass of the retained fraction on the sieve is determined. Sieve analysis can be carried out by using individual sieves or with a set of sieves either manually or using a machine. The transport of the coating powder particles through the sieve mesh is due to either gravity, shear and/or flow forces.

5 Apparatus

Ordinary laboratory apparatus, together with the following:

5.1 Test sieve with a sieve bottom according to ISO 3310-1 and ISO 3310-2, circular with a sieving area having a diameter of 200 mm. Sieves with a sieving area having a diameter of 300 mm may also be used. The frame and the mesh of the test sieves shall be of metal. The range of nominal mesh apertures shall be between 32 μm and 300 μm or as agreed and shall comply with the requirements of ISO 565 for supplementary sizes, see [Annex A](#). The test sieve shall be covered with a transparent lid.

The choice of mesh apertures, see [Annex A](#), will depend on the test sample. If the approximate particle size distribution of the sample is known, then it is necessary to use only those test sieves that are appropriate to the particular particle size range. It is also permissible to restrict the choice of test sieves to those that give sufficient data for a specific purpose. Appropriate details shall be agreed between the interested parties.

5.2 Air-jet sieve apparatus (see Figure 1), consisting of a cylindrical casing which contains the test sieve (5.1). In the base of the casing shall be an outlet to which an extractor fan is connected and an air inlet to permit the injection of air.

The air inlet is connected to a jet rotating at 20 min^{-1} to 25 min^{-1} and consisting of a slot-shaped nozzle arranged radially beneath and very close to the sieve mesh. When the jet rotates, it blows air continuously through the mesh, preventing the coating powder particles from blocking the test sieve. The air is then extracted through the outlet, drawing the finer particles through the sieve.

The flow of air is controlled by adjusting a slot at the outlet.

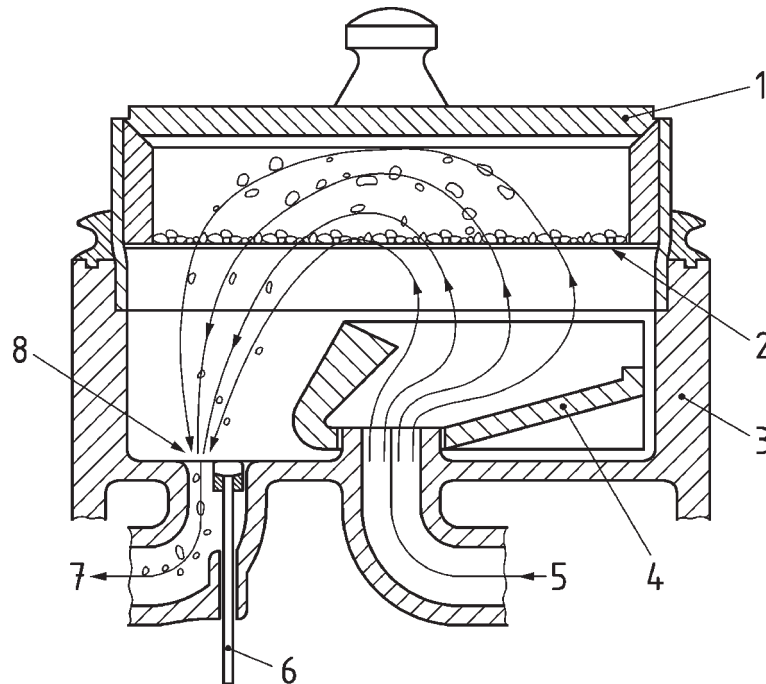
**Key**

- 1 Transparent lid
- 2 Sieve
- 3 Casing
- 4 Rotating rim
- 5 Air inlet
- 6 Manometer
- 7 To vacuum pump
- 8 Adjustable slot

STANDARD PREVIEW
(standards.iteh.ai)

SIST EN ISO 8130-1:2019

standards.iteh.ai/catalog/standards/sist/a13d3fa7-b361-4922-8aa8-8800074bc713/sist-en-iso-8130-1-2019

NOTE This diagram illustrates the functioning of the air-jet sieve apparatus and is schematic only.

Figure 1 — Air-jet sieve apparatus

5.3 Vibratory sieve machine, consisting of cylindrical casing which contains the test sieve (5.1). The machine can be set up with either a single sieve or can be used with a set of sieves stacked in order of decreasing particle size thereby allowing particles to pass through the apertures into a collection pan at the bottom of the stack. The degree of vibration may be machine dependent or as agreed between interested parties. It is important to ensure that the coating powder particles are not shattered due to attrition.

5.4 Balance, capable of weighing to the nearest 0,01 g.

5.5 Mallet, of light construction, with a plastic head, suitable for tapping the apparatus to dislodge deposited powder.

5.6 Magnifying glass, of magnification at least $\times 5$.

5.7 Ultrasonic cleaning bath, to clean the sieve mesh.

5.8 Soft hair cleaning pencil brush, to manually clear the apertures.

ISO/DIS 8130-1:2018(E)**6 Sampling**

Take a representative sample of the product under test as described in ISO 15528.

7 Choice of sieving method and sieve selectivity

The following sieving methods may be used for coating powders:

- a) manual sieving by hand using individual sieves or a set of sieves, if necessary with assistance by a gaseous, stationary fluid;
- b) machine sieving with a stationary single sieve or set of sieves with a gaseous, moving fluid, e.g. an air-jet sieve or a set of sieves with a vibrant air column;
- c) machine sieving with a moving single sieve or moving set of sieves (vibratory-sieve machine).

The choice depends on the requirements as agreed between the interested parties.

Factors which can influence sieving include, the nominal mesh size of the test sieve and its classification limit, these may not be identical and the latter should be determined with respect to the sieving method.

Sieve selectivity and its classification limit can be affected by the following:

- a) The apparatus and method:
 - 1) type of the sieve
 - 2) size and shape of the sieve mesh
 - 3) distribution of the sieve mesh apertures
 - 4) effective sieve area
 - 5) movement of the sieve
 - 6) sieving aid
 - 7) proportion of the not blinded sieve mesh
- b) The test material:
 - 1) mass and bulk volume
 - 2) particle size distribution
 - 3) shape of the particles
 - 4) agglomeration
 - 5) humidity
 - 6) hygroscopicity
 - 7) static
 - 8) strength (resistance against attrition)
- c) The test equipment
 - 1) sieving duration
 - 2) air jet flow
 - 3) vibration frequency