**Bonded abrasive products —
Permissible unbalances of grinding
wheels as delivered — Static testing**

*Produits abrasifs agglomérés — Balourds admissibles des meules en
état de livraison — Contrôle statique*

iTeh STANDARD PREVIEW
(standards.iteh.ai)

[ISO 6103:2014](https://standards.iteh.ai/catalog/standards/sist/1c6f4f8e-4cf6-4945-893e-039dbffac1b7/iso-6103-2014)

<https://standards.iteh.ai/catalog/standards/sist/1c6f4f8e-4cf6-4945-893e-039dbffac1b7/iso-6103-2014>



iTeh STANDARD PREVIEW
(standards.iteh.ai)

ISO 6103:2014

<https://standards.iteh.ai/catalog/standards/sist/1c6f4f8e-4cf6-4945-893e-039dbffac1b7/iso-6103-2014>



COPYRIGHT PROTECTED DOCUMENT

© ISO 2014

All rights reserved. Unless otherwise specified, no part of this publication may be reproduced or utilized otherwise in any form or by any means, electronic or mechanical, including photocopying, or posting on the internet or an intranet, without prior written permission. Permission can be requested from either ISO at the address below or ISO's member body in the country of the requester.

ISO copyright office
Case postale 56 • CH-1211 Geneva 20
Tel. + 41 22 749 01 11
Fax + 41 22 749 09 47
E-mail copyright@iso.org
Web www.iso.org

Published in Switzerland

Contents

	Page
Foreword	iv
1 Scope	1
2 Terms and definitions	1
3 Permissible unbalance, U_a	3
4 Measuring intrinsic unbalance	3
5 Checking intrinsic unbalance	4
5.1 Verification and acceptance	4
5.2 Determination of m_a	4
5.3 Acceptance testing of the grinding wheel	5
Bibliography	7

iTeh STANDARD PREVIEW (standards.iteh.ai)

[ISO 6103:2014](https://standards.iteh.ai/catalog/standards/sist/1c6f4f8e-4cf6-4945-893e-039dbffac1b7/iso-6103-2014)

<https://standards.iteh.ai/catalog/standards/sist/1c6f4f8e-4cf6-4945-893e-039dbffac1b7/iso-6103-2014>

Foreword

ISO (the International Organization for Standardization) is a worldwide federation of national standards bodies (ISO member bodies). The work of preparing International Standards is normally carried out through ISO technical committees. Each member body interested in a subject for which a technical committee has been established has the right to be represented on that committee. International organizations, governmental and non-governmental, in liaison with ISO, also take part in the work. ISO collaborates closely with the International Electrotechnical Commission (IEC) on all matters of electrotechnical standardization.

The procedures used to develop this document and those intended for its further maintenance are described in the ISO/IEC Directives, Part 1. In particular the different approval criteria needed for the different types of ISO documents should be noted. This document was drafted in accordance with the editorial rules of the ISO/IEC Directives, Part 2 (see www.iso.org/directives).

Attention is drawn to the possibility that some of the elements of this document may be the subject of patent rights. ISO shall not be held responsible for identifying any or all such patent rights. Details of any patent rights identified during the development of the document will be in the Introduction and/or on the ISO list of patent declarations received (see www.iso.org/patents).

Any trade name used in this document is information given for the convenience of users and does not constitute an endorsement.

For an explanation on the meaning of ISO specific terms and expressions related to conformity assessment, as well as information about ISO's adherence to the WTO principles in the Technical Barriers to Trade (TBT) see the following URL: Foreword - Supplementary information

The committee responsible for this document is ISO/TC 29, *Small tools*, Subcommittee SC 5, *Grinding wheels and abrasives*.

This fourth edition cancels and replaces the third edition (ISO 6103:2005), which has been technically revised to introduce the following significant changes:

- a) the scope has been amended with respect to minimum outside diameters;
- b) the normative references to ISO 603 series have been deleted;
- c) types of bonded abrasive products for hand-held grinding machines in [Table 1](#) have been amended;
- d) diameter ranges in [Table 1](#) have been corrected;
- e) a bibliography has been added.

Bonded abrasive products — Permissible unbalances of grinding wheels as delivered — Static testing

1 Scope

This International Standard specifies the maximum permissible values of unbalances for bonded abrasive wheels with an outside diameter $D \geq 125$ mm and maximum operating speed $v_s \geq 16$ m/s, in the as-delivered condition.

It also specifies the method for measuring the unbalance and the practical method for testing whether a grinding wheel is acceptable or not.

This International Standard is applicable to bonded abrasive wheels in the as-delivered condition.

This International Standard is not applicable to

- diamond, cubic boron nitride or natural stone grinding wheels, or
- centreless control wheels, lapping and disc wheels, ball wheels or glass grinding wheels.

NOTE 1 The values given refer to the grinding wheel itself, independent of any unbalance which may exist in the balancing arbor or in the means of fastening it to this arbor. These various elements, together with the flanges or hub-flanges, are assumed to be balanced, homogeneous and free from geometrical defects.

NOTE 2 The effects of unbalance are basically

- additional stresses on the arbor, the machine and its mounting,
- excessive wear of the bearings,
- vibration prejudicial to the quality of machining and increased internal stresses in the grinding wheel, and increased operator fatigue.

2 Terms and definitions

For the purposes of this document, the following terms and definitions apply.

2.1

unbalance

product of radius and mass

Note 1 to entry: Radius is expressed in millimetres. Mass is expressed in grams. The product of radius and mass is expressed in grams multiplied by millimetres.

2.2

intrinsic unbalance of a grinding wheel

U_i

product of the mass m_1 of the grinding wheel and the distance e between its centre of mass G (centre of gravity) and the axis O of its bore

Note 1 to entry: See [Figure 1](#).

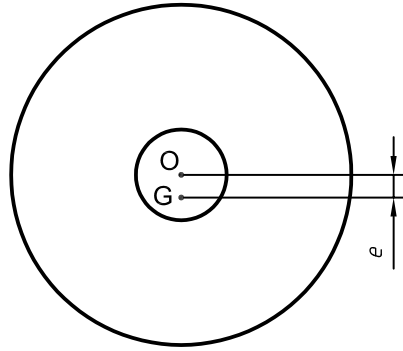

Figure 1 — Intrinsic unbalance of a grinding wheel

**2.3
measured unbalance**

U_c
product of a mass m_2 , affixed to the grinding wheel to balance it and the distance between the centre of mass (G_{m2}) (centre of gravity) of the mass m_2 and the axis O of the grinding wheel bore

Note 1 to entry: See [Figure 2](#).

Note 2 to entry: In practice, this distance is equal to the radius r of the grinding wheel.

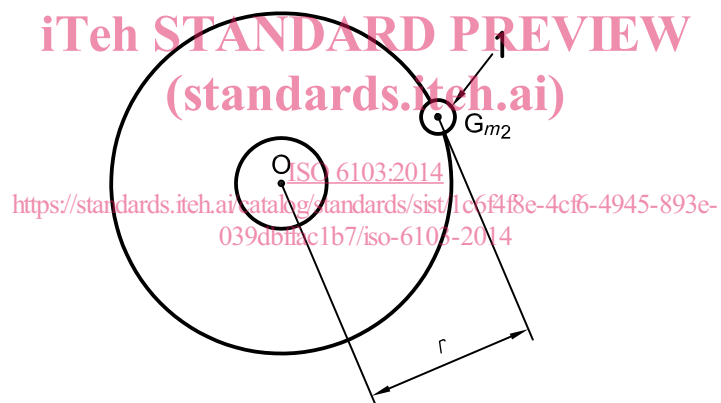

Key
1 mass m_2

Figure 2 — Measured unbalance

3 Permissible unbalance, U_a

On the basis of experience, the maximum permissible unbalance U_a is determined using a mass $m_a = U_a/r$, such that

$$m_a = k\sqrt{m_1} \quad (1)$$

where

r is the radius of the grinding wheels, in millimetres;

m_a is the mass whose centre is located on the circumference of the grinding wheel, in grams;

m_1 is the mass of the grinding wheel, in grams;

k is a coefficient which depends on the nature and usage of the grinding wheel.

The values of k are given in [Table 1](#) and the values of m_a , as a function of m_1 and k , are shown in [Figure 5](#).

The values of k have been selected on the basis of experience so that the resulting unbalance allows for normal usage of the grinding wheel.

4 Measuring intrinsic unbalance

Place a balancing arbor through the bore of the grinding wheel to hold its mid-plane in a vertical position. For straight wheels or wheels of similar shape, the wheel is free-standing; wheels of other shapes may be supported using suitable flanges.

Rest the balancing arbor on two parallel horizontal bevelled guide-bars or cylindrical bars (see [Figure 3](#)), or on a balancing stand consisting of two pairs of overlapping, freely rotating, steel discs (see [Figure 4](#)), so that the grinding wheel attains an equilibrium position with minimum friction.

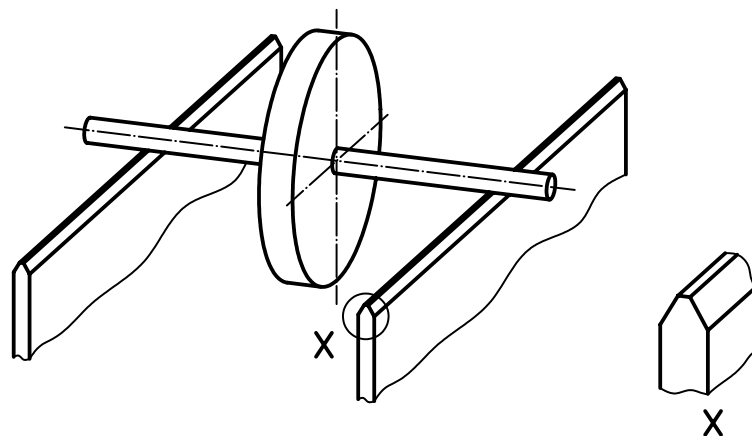

Alternative: The two bevelled guide-bars may be replaced by two cylindrical bars.

Figure 3 — Balancing arbor on guide bars

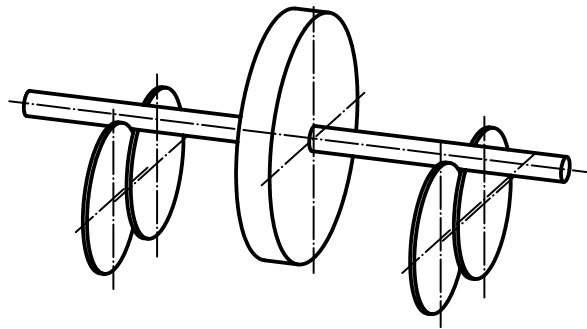

Figure 4 — Balancing arbor on steel discs

The clearance between the balancing arbor and the bore of the grinding wheel shall not exceed 0,4 mm.

The arbor and the supports (guide-bars, bars or discs) shall have an adequate surface hardness and an appropriate surface condition to minimize friction.

When the grinding wheel attains the equilibrium position, its centre of mass is then as low as possible. In this position, mark the upper peripheral point of the grinding wheel.

Rotate the grinding wheel through 90° to bring this mark into the horizontal plane for the arbor axis.

Determine the mass m_2 which, when affixed to the periphery of the grinding wheel at the mark, maintains the grinding wheel in equilibrium. The amount of unbalance thus introduced, $U_c = m_2 \cdot r$, is equal and opposite to the intrinsic unbalance of the wheel.

The value of the mass m_2 is used to determine the intrinsic unbalance of the wheel using Formula (2):

$$U_i = U_c = m_2 \cdot r \quad \text{ISO 6103:2014} \quad (2)$$

<https://standards.iteh.ai/catalog/standards/sist/1c6f4f8e-4cf6-4945-893e-039dbffac1b7/iso-6103-2014>

5 Checking intrinsic unbalance

5.1 Verification and acceptance

Verify the intrinsic unbalance according to the method specified in [Clause 4](#).

A grinding wheel is only acceptable if its intrinsic unbalance U_i is less than or equal to the permissible unbalance U_a , i.e.

$$U_i \leq U_a \quad (3)$$

The testing is done with a mass

$$m_a = \frac{U_a}{r} \quad (4)$$

5.2 Determination of m_a

From [Table 1](#), determine the coefficient k by reading off the value according to the various parameters related to the grinding wheel and its application.

[Figure 5](#) then gives the values of the mass m_a , in grams, as a function of the mass m_1 of the wheel, in grams, and the coefficient k .

5.3 Acceptance testing of the grinding wheel

With the grinding wheel mounted in accordance with [Clause 4](#), place a mass m_a as determined in [5.2](#) on the periphery of the grinding wheel at the mark. If the wheel remains stationary or rotates so that the mark is at the bottom, the grinding wheel is accepted; otherwise, it is rejected.

Table 1 — Values of the coefficient k for bonded abrasive products

Grinding method	Type of machine	Type of bonded abrasive product	Dimensions		Coefficient k for maximum operating speed v_s		
			D mm	T mm	m/s		
					$16 \leq v_s \leq 40$	$40 < v_s \leq 63$	$63 < v_s \leq 125$
Grinding (deburring, fettling and snagging)	Hand-held grinding machines	Types 1/4/27/28/29/35 and 36	$125 \leq D \leq 150$	—	0,40	0,32	0,25
			$150 < D \leq 180$	—	0,40	0,32	0,20
			$D > 180$	$T \leq 6$	0,40	0,32	0,20
		$T > 6$		0,32	0,25	0,20	
		Types 6 and 11	all dimensions		0,40	0,32	—
Grinding (deburring, fettling and snagging)	Stationary grinding machines, swing frame grinding machines and other grinding machines	Types 1/2/35 and 36	all dimensions		0,63	0,50	0,40
High-pressure grinding	Stationary grinding machines	Type 1	all dimensions		0,8		
Grinding – precision grinding – external cylindrical grinding – surface grinding – sharpening	Stationary grinding machines	all types	$125 \leq D \leq 300$	all dimensions	0,25	0,20	0,16
			$300 < D \leq 610$		0,32	0,25	0,20
			$D > 610$		0,40	0,32	0,25
Cutting-off	Hand-held cutting-off machines	Types 41 and 42	$125 \leq D \leq 406$	—	0,40	0,32	0,20
	Stationary cutting-off machines	Type 41 and 42	$D \leq 300$	—	0,50	0,40	0,32
			$D > 300$	—	0,63	0,50	0,40