

# SLOVENSKI STANDARD

## SIST EN 4534-2:2016

01-november-2016

Nadomešča:

SIST EN 4534-2:2009

---

**Aeronavtika - Drsne puše iz aluminijeve zlitine s samomazalno oblogo, serija za večje obremenitve - 2. del: Mere in nosilnosti - Colski tip**

Aerospace series - Bushes, plain in aluminium alloy with self-lubricating liner, elevated load - Part 2: Dimensions and loads - Inch series

Luft- und Raumfahrt - Buchsen aus Aluminiumlegierung, mit selbstschmierender Beschichtung, erhöhte Belastung - Teil 2: Maße und Belastungen - Inch-Reihe

Série aérospatiale - Bagues en alliage d'aluminium à garniture autolubrifiante, charge élevée - Partie 2: Dimensions et charges - Série en inches

**Ta slovenski standard je istoveten z: EN 4534-2:2016**

---

**ICS:**

49.025.20	Aluminij	Aluminium
49.035	Sestavni deli za letalsko in vesoljsko gradnjo	Components for aerospace construction

**SIST EN 4534-2:2016**

**en,fr,de**

**iTeh STANDARD PREVIEW**  
**(standards.iteh.ai)**

SIST EN 4534-2:2016

<https://standards.iteh.ai/catalog/standards/sist/c8a385c0-4aab-43b5-b759-20ccb4c790c9/sist-en-4534-2-2016>

EUROPEAN STANDARD

EN 4534-2

NORME EUROPÉENNE

EUROPÄISCHE NORM

September 2016

ICS 49.035

Supersedes EN 4534-2:2009

English Version

## Aerospace series - Bushes, plain in aluminium alloy with self-lubricating liner, elevated load - Part 2: Dimensions and loads - Inch series

Série aérospatiale - Bagues en alliage d'aluminium à garniture autolubrifiante, charge élevée - Partie 2: Dimensions et charges - Série en inches

Luft- und Raumfahrt - Buchsen aus Aluminiumlegierung, mit selbstschmierender Beschichtung, erhöhte Belastung - Teil 2: Maße und Belastungen - Inch-Reihe

This European Standard was approved by CEN on 4 March 2016.

CEN members are bound to comply with the CEN/CENELEC Internal Regulations which stipulate the conditions for giving this European Standard the status of a national standard without any alteration. Up-to-date lists and bibliographical references concerning such national standards may be obtained on application to the CEN-CENELEC Management Centre or to any CEN member.

This European Standard exists in three official versions (English, French, German). A version in any other language made by translation under the responsibility of a CEN member into its own language and notified to the CEN-CENELEC Management Centre has the same status as the official versions.

CEN members are the national standards bodies of Austria, Belgium, Bulgaria, Croatia, Cyprus, Czech Republic, Denmark, Estonia, Finland, Former Yugoslav Republic of Macedonia, France, Germany, Greece, Hungary, Iceland, Ireland, Italy, Latvia, Lithuania, Luxembourg, Malta, Netherlands, Norway, Poland, Portugal, Romania, Slovakia, Slovenia, Spain, Sweden, Switzerland, Turkey and United Kingdom.



EUROPEAN COMMITTEE FOR STANDARDIZATION  
COMITÉ EUROPÉEN DE NORMALISATION  
EUROPÄISCHES KOMITEE FÜR NORMUNG

**CEN-CENELEC Management Centre: Avenue Marnix 17, B-1000 Brussels**

<b>Contents</b>		Page
<b>European foreword .....</b>		<b>3</b>
<b>1</b>	<b>Scope.....</b>	<b>4</b>
<b>2</b>	<b>Normative references.....</b>	<b>4</b>
<b>3</b>	<b>Terms and definitions .....</b>	<b>4</b>
<b>4</b>	<b>Requirements.....</b>	<b>4</b>
<b>5</b>	<b>Designation .....</b>	<b>13</b>
<b>6</b>	<b>Marking.....</b>	<b>14</b>
<b>7</b>	<b>Technical specification .....</b>	<b>14</b>
<b>8</b>	<b>Design recommendation .....</b>	<b>14</b>
<b>Annex A (informative) Standard evolution form.....</b>		<b>15</b>

**iTeh STANDARD PREVIEW**  
**(standards.iteh.ai)**

[SIST EN 4534-2:2016  
https://standards.iteh.ai/catalog/standards/sist/c8a385c0-4aab-43b5-b759-20ccb4c790c9/sist-en-4534-2-2016](https://standards.iteh.ai/catalog/standards/sist/c8a385c0-4aab-43b5-b759-20ccb4c790c9/sist-en-4534-2-2016)

## European foreword

This document (EN 4534-2:2016) has been prepared by the Aerospace and Defence Industries Association of Europe - Standardization (ASD-STAN).

After enquiries and votes carried out in accordance with the rules of this Association, this Standard has received the approval of the National Associations and the Official Services of the member countries of ASD, prior to its presentation to CEN.

This European Standard shall be given the status of a national standard, either by publication of an identical text or by endorsement, at the latest by March 2017, and conflicting national standards shall be withdrawn at the latest by March 2017.

Attention is drawn to the possibility that some of the elements of this document may be the subject of patent rights. CEN [and/or CENELEC] shall not be held responsible for identifying any or all such patent rights.

This document supersedes EN 4534-2:2009.

According to the CEN-CENELEC Internal Regulations, the national standards organizations of the following countries are bound to implement this European Standard: Austria, Belgium, Bulgaria, Croatia, Cyprus, Czech Republic, Denmark, Estonia, Finland, Former Yugoslav Republic of Macedonia, France, Germany, Greece, Hungary, Iceland, Ireland, Italy, Latvia, Lithuania, Luxembourg, Malta, Netherlands, Norway, Poland, Portugal, Romania, Slovakia, Slovenia, Spain, Sweden, Switzerland, Turkey and the United Kingdom.

## EN 4534-2:2016 (E)

## 1 Scope

This European Standard specifies the characteristics of plain bushes in aluminium alloy with self-lubricating liner, elevated load for aerospace applications.

The bushes are intended for use in fixed or moving parts of the aircraft structure and control mechanisms.

They shall be used in the temperature range – 55 °C to 121 °C.

## 2 Normative references

The following documents, in whole or in part, are normatively referenced in this document and are indispensable for its application. For dated references, only the edition cited applies. For undated references, the latest edition of the referenced document (including any amendments) applies.

EN 2101, *Aerospace series — Chromic acid anodizing of aluminium and wrought aluminium alloys*

EN 2284, *Aerospace series — Sulphuric acid anodizing of aluminium and wrought aluminium alloys*

EN 2311, *Aerospace series — Bushes with self-lubricating liner — Technical specification*

EN 2318, *Aerospace series — Aluminium alloy AL-P2024- — T3511 — Extruded bars and sections —  $1,2 \text{ mm} \leq a \text{ or } D \leq 150 \text{ mm}$*

EN 2424, *Aerospace series — Marking of aerospace products*

EN 4704, *Aerospace series — Tartaric-Sulphuric Acid anodising of aluminium and aluminium wrought alloys for corrosion protection and paint pre-treatment (TSA)*

ISO 2768-1, *General tolerances — Part 1: Tolerances for linear and angular dimensions without individual tolerance indications*

TR 4475, *Aerospace series — Bearings and mechanical transmissions for airframe applications — Vocabulary*<sup>1)</sup>

## 3 Terms and definitions

For the purposes of this document, the terms and definitions given in TR 4475 apply.

## 4 Requirements

### 4.1 Configuration, dimensions, tolerances and mass

According to Figure 1 and Tables 1 and 3. Dimensions apply after surface treatment. Dimensions and tolerances are expressed in millimetres (inches). Except for roughness given in micrometres (micro inches).

General tolerances shall be ISO 2768-m in accordance with ISO 2768-1.

---

1) Published as ASD-STAN Technical Report at the date of publication of this European Standard.  
<http://www.asd-stan.org/>

## 4.2 Surface roughness

According to Figure 1.

## 4.3 Materials

Bush: Aluminium alloy according to EN 2318.

Liner: Self-lubricating wear resistant material consistent with the requirements of EN 2311.

## 4.4 Surface treatment

See Table 1 and Figure 1.

**Table 1 — Surface treatment**

Code	Surface treatment	Remarks
R	Chromic acid anodizing according to EN 2101 Type A or Sulphic acid anodizing according to EN 2284 Type A	Pre-treatment for painting
S	Chromic acid anodizing according to EN 2101 Type A (unsealed)	Pre-treatment for painting
T	Chromic acid anodizing according to EN 2101 Type B (sealed)	Corrosion protection
U	Sulphic acid anodizing according to EN 2284 Type A (unsealed)	Pre-treatment for painting
V	Sulphic acid anodizing according to EN 2284 Type B (sealed)	Corrosion protection
N	Tartaric-Sulphuric-Acid anodizing according to EN 4704 (unsealed)	Pre-treatment for painting
M	Tartaric-Sulphuric-Acid anodizing according to EN 4704 (sealed)	Corrosion protection

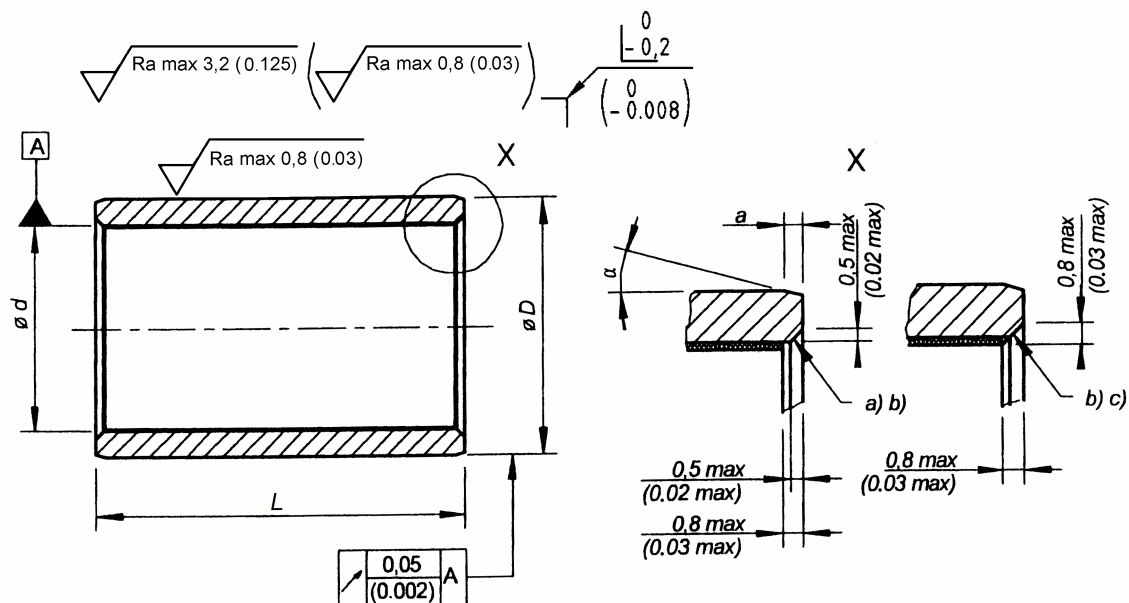
**Key**

- a Chamfer machined before bonding
- b Chamfer or radius at manufacturer's option
- c Chamfer machined after bonding

ITeH STANDARD PREVIEW  
(standards.iteh.ai)

Figure 1 – Configuration

SIST EN 4534-2:2016

<https://standards.iteh.ai/catalog/standards/sist/c8a385c0-4aab-43b5-b759-20ccb4c790c9/sist-en-4534-2-2016>



Table 2 — Dimensions and tolerances

Diameter code <sup>a</sup>	Nominal diameter	$d$	$D$	$a$	$\alpha$
		$\begin{matrix} 0 \\ -0,025 \\ \left( \begin{matrix} 0 \\ -0,001\ 0 \end{matrix} \right) \end{matrix}$	$\begin{matrix} \pm 0,013 \\ (\pm 0.000\ 5) \end{matrix}$		$\pm 2^\circ$
04	6,350 (0.250 0)	6,388 (0.251 5)	9,550 (0.376 0)	0,50 to 0,75 (0.020 to 0.030)	15°
05	7,938 (0.312 5)	7,976 (0.314 0)	11,140 (0.438 6)		
06	9,525 (0.375 0)	9,563 (0.376 5)	12,730 (0.501 2)		
07	11,113 (0.437 5)	11,151 (0.439 0)	14,321 (0.563 8)		
08	12,700 (0.500 0)	12,738 (0.501 5)	15,913 (0.626 5)		
09	14,288 (0.562 5)	14,326 (0.564 0)	17,506 (0.689 2)		
10	15,875 (0.625 0)	15,913 (0.626 5)	20,681 (0.814 2)		
11	17,463 (0.687 5)	17,501 (0.689 0)	22,268 (0.876 7)		
12	19,050 (0.750 0)	19,088 (0.751 5)	23,858 (0.939 3)		
14	22,225 (0.875 0)	22,263 (0.876 5)	27,038 (1.064 5)		
16	25,400 (1.000 0)	25,438 (1.001 5)	30,221 (1.189 8)		
18	28,575 (1.125 0)	28,613 (1.126 5)	33,396 (1.314 8)		
20	31,750 (1.250 0)	31,788 (1.251 5)	36,571 (1.439 8)		
22	34,925 (1.375 0)	34,963 (1.376 5)	39,746 (1.564 8)		
24	38,100 (1.500 0)	38,138 (1.501 5)	44,508 (1.752 3)		
26	41,275 (1.625 0)	41,313 (1.626 5)	47,683 (1.877 3)		
28	44,450 (1.750 0)	44,488 (1.751 5)	50,858 (2.002 3)		
32	50,800 (2.000 0)	50,838 (2.001 5)	57,208 (2.252 3)		

<sup>a</sup> Diameter code corresponds to nominal diameter  $d$  in 1/16 inch.