



SLOVENSKI STANDARD

SIST EN 4674-001:2018

01-marec-2018

Aeronavtika - Električni kabli, namestitvev - Samoovojna zaslonska (EMI) zaščitna obojka - 001. del: Tehnična specifikacija

Aerospace series - Electrical cables, installation - Self-wrapping shielding (EMI) protective sleeve - Part 001: Technical specification

Luft- und Raumfahrt - Elektrische Leitungen, Installation - Selbstschließender abschirmender (EMI) Schutzschlauch - Teil 001: Technische Lieferbedingungen

Série aérospatiale - Câbles électriques, installation - Gaine de protection blindée (EMI) auto-fermable - Partie 001 : Spécification technique

<https://standards.iteh.ai/catalog/standards/sist/6eca916f-c533-4102-b53b-43396e57814c/sist-en-4674-001-2018>

Ta slovenski standard je istoveten z: EN 4674-001:2017

ICS:

29.060.20	Kabli	Cables
49.060	Letalska in vesoljska električna oprema in sistemi	Aerospace electric equipment and systems

SIST EN 4674-001:2018

en,fr,de

iTeh STANDARD PREVIEW
(standards.iteh.ai)

[SIST EN 4674-001:2018](#)

<https://standards.iteh.ai/catalog/standards/sist/6eca916f-c533-4102-b53b-43396e57814c/sist-en-4674-001-2018>

EUROPEAN STANDARD

EN 4674-001

NORME EUROPÉENNE

EUROPÄISCHE NORM

March 2017

ICS 49.060

Supersedes EN 4674-001:2015

English Version

Aerospace series - Electrical cables, installation - Self-wrapping shielding (EMI) protective sleeve - Part 001: Technical specification

Série aérospatiale - Câbles électriques, installation -
Gaine de protection blindée (EMI) auto-fermable -
Partie 001 : Spécification technique

Luft- und Raumfahrt - Elektrische Leitungen,
Installation - Selbstschließender abschirmender (EMI)
Schutzschlauch - Teil 001: Technische
Lieferbedingungen

This European Standard was approved by CEN on 2 January 2017.

CEN members are bound to comply with the CEN/CENELEC Internal Regulations which stipulate the conditions for giving this European Standard the status of a national standard without any alteration. Up-to-date lists and bibliographical references concerning such national standards may be obtained on application to the CEN-CENELEC Management Centre or to any CEN member.

This European Standard exists in three official versions (English, French, German). A version in any other language made by translation under the responsibility of a CEN member into its own language and notified to the CEN-CENELEC Management Centre has the same status as the official versions.

CEN members are the national standards bodies of Austria, Belgium, Bulgaria, Croatia, Cyprus, Czech Republic, Denmark, Estonia, Finland, Former Yugoslav Republic of Macedonia, France, Germany, Greece, Hungary, Iceland, Ireland, Italy, Latvia, Lithuania, Luxembourg, Malta, Netherlands, Norway, Poland, Portugal, Romania, Serbia, Slovakia, Slovenia, Spain, Sweden, Switzerland, Turkey and United Kingdom.



EUROPEAN COMMITTEE FOR STANDARDIZATION
COMITÉ EUROPÉEN DE NORMALISATION
EUROPÄISCHES KOMITEE FÜR NORMUNG

CEN-CENELEC Management Centre: Avenue Marnix 17, B-1000 Brussels

Contents	Page
European foreword.....	3
1 Scope	4
2 Normative references	4
3 Terms, definitions and symbols.....	5
4 Description	5
5 Design	6
6 Definition drawings and mass.....	9
7 Test methods	10
8 Quality assurance.....	16
9 Example for designation in product standards.....	16
10 Delivery conditions	16
11 Packaging.....	16
12 Marking.....	16
13 Storage	16

[SIST EN 4674-001:2018](https://standards.itech.ai/catalog/standards/sist/6cca916f-c533-4102-b53b-43396e57814c/sist-en-4674-001-2018)
<https://standards.itech.ai/catalog/standards/sist/6cca916f-c533-4102-b53b-43396e57814c/sist-en-4674-001-2018>

European foreword

This document (EN 4674-001:2017) has been prepared by the Aerospace and Defence Industries Association of Europe - Standardization (ASD-STAN).

After enquiries and votes carried out in accordance with the rules of this Association, this Standard has received the approval of the National Associations and the Official Services of the member countries of ASD, prior to its presentation to CEN.

This European Standard shall be given the status of a national standard, either by publication of an identical text or by endorsement, at the latest by September 2017, and conflicting national standards shall be withdrawn at the latest by September 2017.

Attention is drawn to the possibility that some of the elements of this document may be the subject of patent rights. CEN [and/or CENELEC] shall not be held responsible for identifying any or all such patent rights.

This document supersedes EN 4674-001:2015.

According to the CEN-CENELEC Internal Regulations, the national standards organizations of the following countries are bound to implement this European Standard: Austria, Belgium, Bulgaria, Croatia, Cyprus, Czech Republic, Denmark, Estonia, Finland, Former Yugoslav Republic of Macedonia, France, Germany, Greece, Hungary, Iceland, Ireland, Italy, Latvia, Lithuania, Luxembourg, Malta, Netherlands, Norway, Poland, Portugal, Romania, Serbia, Slovakia, Slovenia, Spain, Sweden, Switzerland, Turkey and the United Kingdom.

<https://standards.iteh.ai/catalog/standards/sist/6eca916f-c533-4102-b53b-43396e57814c/sist-en-4674-001-2018>

EN 4674-001:2017 (E)**1 Scope**

This European Standard specifies the general characteristics, qualification and acceptance requirements for self-wrapping shielding (EMI) protective sleeve designed for EMI shielding of cable and cable bundles for aerospace applications.

2 Normative references

The following referenced documents are indispensable for the application of this document. For dated references, only the edition cited applies. For undated references, the latest edition of the referenced document (including any amendments) applies.

EN 2267-010, *Aerospace series — Cables, electrical, for general purpose — Operating temperatures between - 55 °C and 260 °C — Part 010: DR family, single UV laser printable — Product standard*

EN 2591-214, *Aerospace series — Elements of electrical and optical connection — Test methods — Part 214: Lightning strike, current and voltage pulse*

EN 2591-307, *Aerospace series — Elements of electrical and optical connection — Test methods — Part 307: Salt mist*

EN 2825, *Aerospace series — Burning behaviour of non metallic materials under the influence of radiating heat and flames — Determination of smoke density*

EN 2826, *Aerospace series — Burning behaviour of non metallic materials under the influence of radiating heat and flames — Determination of gas components in the smoke*

EN 3197, *Aerospace series — Design and installation of aircraft electrical and optical interconnection systems*

EN 3475, *Aerospace series — Cables, electrical, aircraft use — Test methods*¹⁾

EN 3844-1, *Aerospace series — Flammability of non metallic materials — Part 1: Small burner test, vertical — Determination of the vertical flame propagation*

EN 4674-002, *Aerospace series — Electrical cables, installation — Self-wrapping shielding (EMI) protective sleeve — Part 002: General and list of product standard*

EN 4674-003, *Aerospace series — Electrical cables, installation — Self-wrapping shielding (EMI) protective sleeve — Part 003: Open sleeve — Inside pressurized area — EMI protection 5 kA — Temperature range - 65 °C to 200 °C — Product standard*

EN 4674-004, *Aerospace series — Electrical cables, installation — Self-wrapping shielding (EMI) protective sleeve — Part 004: Open sleeve — Outside pressurized area — EMI protection 10 kA — Temperature range - 65 °C to 200 °C — Product standard*

¹⁾ All its parts quoted in this European Standard.

EN 6059, *Aerospace series — Electrical cables, installation — Protection sleeves — Test methods* ¹⁾

EN 9133, *Aerospace series — Quality management systems — Qualification procedure for aerospace standard parts*

ISO 8815, *Aircraft — Electrical cables and cables harnesses — Vocabulary*

IEC 62153-4-3, *Metallic communication cable test methods — Part 4-3: Electromagnetic compatibility (EMC) — Surface transfer impedance — Triaxial method* ²⁾

ASTM B33, *Standard Specification for Tin-Coated Soft or Annealed Copper Wire for Electrical Purposes* ³⁾

ASTM B298, *Standard Specification for Silver-Coated Soft or Annealed Copper Wire* ³⁾

ASTM B355, *Standard Specification for Nickel-Coated Soft or Annealed Copper Wire* ³⁾

ASTM D4894, *Standard Specification for Polytetrafluoroethylene (PTFE) Granular Molding and Ram Extrusion Materials* ³⁾

TR 4684, *Aerospace series — Electrical technology and component definition* ⁴⁾

3 Terms, definitions and symbols

For the purposes of this document, the terms, definitions and symbols given in ISO 8815 or TR 4684 apply.

iTeh STANDARD PREVIEW
(standards.iteh.ai)

[SIST EN 4674-001:2018](https://standards.iteh.ai/catalog/standards/sist/6cca916f-c533-4102-b53b-43396e57814c/sist-en-4674-001-2018)

4 Description <https://standards.iteh.ai/catalog/standards/sist/6cca916f-c533-4102-b53b-43396e57814c/sist-en-4674-001-2018>

This technical specification covers tubular self-wrappable sleeving, used as EMI protection of different levels. It can be used in pressurized or non-pressurized areas. Easy installation and removal are expected.

These sleeves are built with:

- a particular number of longitudinal wires or group of wires (warps) made of plated copper;
- the wires or group of wires are assembled by weaving mono- and/or multi-filament strands which have aerospace grade mechanical and thermal characteristics;
- optional, transversal-filling strands made of plated copper can be added to provide electrical continuity between longitudinal warps;
- the internal part can be covered by a tape maintained close to the EMI screen, in order to improve the protection of the cables and cable bundle inside.

2) Published by: IEC International Electrotechnical Commission. <http://www.iec.ch/>

3) Published by: ASTM National (US) American Society for Testing and Materials. <http://www.astm.org/>

4) In preparation at the date of publication of this standard.

EN 4674-001:2017 (E)

A sleeve overlap is needed.

See Figures 1 and 2 for illustration.

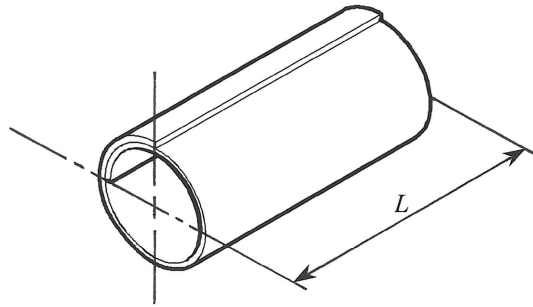
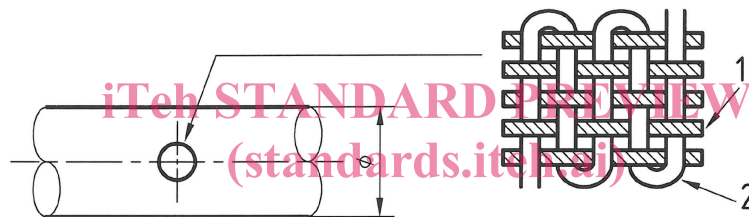

Figure 1



SIST EN 4674-001:2018

<https://standards.iteh.ai/catalog/standards/sist/6eca916f-c533-4102-b53b-43396e57814c/sist-en-4674-001-2018>

Key

- 1 warp
- 2 weft

Figure 2

5 Design

5.1 General requirements

These protection sleeves are intended to meet the following requirements as specified in detail in Clause 7:

- EMI protection of cables and cable bundles,
- non-aggressive to the protected cables and cable bundles,
- resistance to hostile environments, such as temperature and fluid exposure,
- minimum mass,
- mechanical flexibility,
- the minimum bend radius applicable shall be equal to the specified minimum bend radius for cables and cable bundles, as specified in EN 3197 or in the product standard,
- the flammability, smoke emission and toxicity of all parts shall meet the requirements mentioned in the product standard.

5.2 Screen requirements

5.2.1 Materials

Strands used for this European Standard shall be cylindrical and made with high conductivity annealed electrolytic copper (see ASTM B355, ASTM B298, ASTM B33).

On ASTM B355 finished product:

- the elongation prior to rupture, for each class 4 and class 10 copper strand, shall be at least 15 %;
- the elongation prior to rupture, for each class 27 copper strand, shall be at least 8 %;
- the tensile strength, for each copper strand, shall be at least 220 MPa.

5.2.2 Metal plating

The individual strands may be:

- provided with a uniform plating of tin (code B) or silver (code C), or nickel (code D).

Plating thicknesses shall be at least 1,0 µm for silver and at least 1,3 µm for nickel.

When tin plating is authorized, the thickness shall be sufficient to comply with the tests specified in EN 3475-506 and EN 3475-507.

Particular plating thickness will be necessary to provide high resistance to corrosion.

For example, a high resistance to corrosion can be obtained with the use of nickel coated copper strands where the nickel shall not represent less than 27 % of the total mass of the individual strand (also called class 27 or class C27). In this case, the tensile strength for each strand shall be at least 280 MPa. Refer to ASTM B355.

<https://standards.iteh.ai/catalog/standards/sist/6cca916f-c533-4102-b53b-43396e57814c/sist-en-4674-001-2018>

5.2.3 Construction of warps

All wires or group of wires used to build a particular size shall be of the same cross-section, and if inserted as groups of wires using the same number and diameter of strands.

Strands forming an individual group of wires shall not be twisted together and shall run longitudinally as parallel to each other as possible in order to minimize linear resistance, to limit crossover for electrical connection dispersion during installation purpose.

When necessary to ensure a good EMI protection, particular care shall be brought to the necessary electrical link between all warps of a size.

Per sleeve size, the total cross-section shall be sufficient to satisfy the required transfer impedance in the full range of frequencies.