



Designation: ~~D4475-96~~ Designation: **D 4475 - 02 (Reapproved 2008)**

Standard Test Method for Apparent Horizontal Shear Strength of Pultruded Reinforced Plastic Rods By the Short-Beam Method¹

This standard is issued under the fixed designation D 4475; the number immediately following the designation indicates the year of original adoption or, in the case of revision, the year of last revision. A number in parentheses indicates the year of last reapproval. A superscript epsilon (ϵ) indicates an editorial change since the last revision or reapproval.

1. Scope

1.1 This test method covers the determination of the apparent horizontal shear strength of fiber reinforced plastic rods. The specimen is a short beam in the form of lengths of pultruded rods. This test method is applicable to all types of parallel-fiber-reinforced plastic rod samples.

1.2 This test method is primarily used for quality control and specification purposes (see 4.1).

1.3 The values stated in SI units are to be regarded as the standard.

1.4 *This standard does not purport to address all of the safety concerns, if any, associated with its use. It is the responsibility of the user of this standard to establish appropriate safety and health practices and determine the applicability of regulatory limitations prior to use.*

NOTE 1—There is no similar or equivalent ISO standard.

2. Referenced Documents

2.1 *ASTM Standards:*²

D 618 Practice for Conditioning Plastics for Testing

E 4 Practices for Force Verification of Testing Machines

E 691 Practice for Conducting an Interlaboratory Study to Determine the Precision of a Test Method

3. Summary of Test Method

3.1 The horizontal-shear test specimen is center-loaded as shown in Fig. 1. The ends of the specimens rest on two supports that allow the specimen to bend, the load being applied by means of a loading nose at midpoint along the support span, as shown in Fig. 2.

3.2 The specimen is deflected until a shear failure occurs at the midplane of the horizontally supported rod.

4. Significance and Use

4.1 Apparent shear strength determined by this test method is useful for quality control and specification purposes. It is also applicable to research and development programs concerned with interlaminar-shear strength. The apparent shear strength obtained by this test method cannot be used for design purposes, but can be utilized for comparative testing of composite materials, if all failures are in horizontal shear.

4.2 It is recommended that control samples be fabricated with each research test series and that care be used to compare each set of controls with corresponding test series run at different times.

5. Apparatus

5.1 *Testing Machine*—A properly calibrated testing machine that can be operated at a constant rate of crosshead motion, and in which the error in the load measuring system shall not exceed $\pm 1\%$ of the maximum load expected to be measured. The load-indicating mechanism shall be essentially free of inertia lag at the crosshead rate used. The accuracy of the testing machine shall be verified in accordance with Practices E 4.

⁴ This test method is under the jurisdiction of ASTM Committee D-20 on Plastics and is the direct responsibility of Subcommittee D20.18 on Reinforced Thermosetting Plastics.

Current edition approved Nov. 10, 1996. Published May 1997. Originally published as D4475-85. Last previous edition D4475-85(1990).

¹ This test method is under the jurisdiction of ASTM Committee D20 on Plastics and is the direct responsibility of Subcommittee D20.18 on Reinforced Thermosetting Plastics.

Current edition approved March 1, 2008. Published March 2008. Originally approved in 1985. Last previous edition approved in 2002 as D4475-02.

² Annual Book of ASTM Standards, Vol 08.01.

² For referenced ASTM standards, visit the ASTM website, www.astm.org, or contact ASTM Customer Service at service@astm.org. For Annual Book of ASTM Standards volume information, refer to the standard's Document Summary page on the ASTM website.

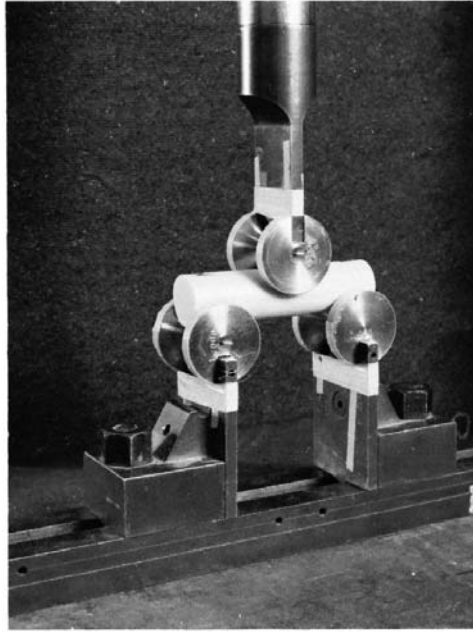

FIG. 1 Test Assembly

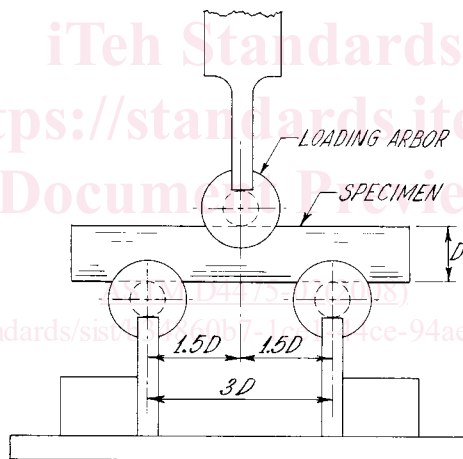

FIG. 2 Span Configuration for 3D Span. Span. May Also Be 4D, 5D, or 6D, as Required to Achieve Shear Mode of Failure

5.2 *Loading Nose and Supports*—Shown in Fig. 2 and Fig. 3. The loading nose shall be a suitable steel rod with a groove in the diameter of the pultruded rod machined in its lower end. The groove diameter shall always have a plus tolerance and zero negative tolerance. The bottom support shall be adjustable to allow for testing at various span/diameter ratios. The surface of the groove shall be free of indentation and burrs, with all sharp edges relieved.

5.3 *Micrometers*—Suitable micrometers for measuring the diameter of the test specimen to an incremental discrimination of at least 0.025 mm (0.001 in.) shall be used.

6. Test Specimen

6.1 The specimen shall be cut from the pultruded rod to a length of one diameter greater than the test span and to a tolerance of plus or minus 0.1 times the diameter.

6.2 *Number of Specimens*—The number of test specimens is optional. However, a minimum of five specimens is required to obtain a satisfactory average and standard deviation.

7. Conditioning

7.1 *Conditioning*—Condition the test specimens at $23 \pm 2^\circ\text{C}$ ($73.4 \pm 3.6^\circ\text{F}$) and $50 \pm 5\%$ relative humidity for not less than 40 h prior to test, in accordance with Procedure A of Practice D 618 for those tests where conditioning is required. In cases of disagreement, the tolerances shall be $\pm 1^\circ\text{C}$ ($\pm 1.8^\circ\text{F}$) and $\pm 2\%$ relative humidity. These conditions are recommended for research