



Designation: D 4884 – 96

Standard Test Method for Strength of Sewn or Thermally Bonded Seams of Geotextiles¹

This standard is issued under the fixed designation D 4884; the number immediately following the designation indicates the year of original adoption or, in the case of revision, the year of last revision. A number in parentheses indicates the year of last reapproval. A superscript epsilon (ϵ) indicates an editorial change since the last revision or reapproval.

1. Scope

1.1 This test method covers the seam strength of geotextiles. The primary distinction of this test method for evaluating seam strength is the width of the specimen. This is in contrast to the more narrow specimen width used in the tensile grab strength test discussed in Test Method D 1683.

1.2 This test method will provide data to indicate the seam strength that can be achieved for each particular geotextile and seam assembly construction.

1.3 The values stated in SI units are to be regarded as standard. The inch-pound units given in parentheses are provided for information only.

1.4 *This standard does not purport to address all of the safety concerns, if any, associated with its use. It is the responsibility of the user of this standard to establish appropriate safety and health practices and determine the applicability of regulatory limitations prior to use.*

2. Referenced Documents

2.1 ASTM Standards:

- D 76 Specification for Tensile Testing Machines for Textiles²
- D 123 Terminology Relating to Textiles²
- D 1683 Test Method for Failure in Sewn Seams of Woven Fabrics²
- D 1776 Practice for Conditioning Textiles for Testing²
- D 1777 Method for Measuring Thickness of Textile Materials²
- D 4354 Practice for Sampling of Geosynthetics for Testing³
- D 4439 Terminology for Geosynthetics³
- D 4595 Test Method for Tensile Properties of Geotextiles by the Wide Width Strip Method³
- D 4632 Test Method for Grab Breaking Load and Elongation of Geotextiles³

¹ This test method is under the jurisdiction of ASTM Committee D-35 on Geosynthetics and is the direct responsibility of Subcommittee D35.01 on Mechanical Properties.

Current edition approved Feb. 10, 1996. Published June 1996. Originally published as D 4884 – 89. Last previous edition D 4884 – 90.

² *Annual Book of ASTM Standards*, Vol 07.01.

³ *Annual Book of ASTM Standards*, Vol 04.13.

E 178 Practice for Dealing with Outlying Observations⁴

E 691 Practice for Conducting an Interlaboratory Study to Determine the Precision of Test Methods⁴

2.2 Federal Standard:

Fed. Std. No. 751a Stitches, Seams, and Stitchings⁵

3. Terminology

3.1 Definitions:

3.1.1 *cross-machine direction*—the direction in the plane of the geotextile perpendicular to the direction of manufacture.

3.1.2 *geotextile, n*—a permeable geosynthetic comprised solely of textiles.

3.1.3 *linear density, n*—mass per unit length; the quotient obtained by dividing the mass of a fiber or yarn by its length.

3.1.4 *machine direction*—the direction in the plane of the geotextile parallel to the direction of manufacture.

3.1.5 *seam allowance, n*—the width of geotextile used in making a seam assembly, for sewn seams bounded by the edge of the geotextile and the furthest stitch line, and for thermally bonded seams bounded by the edge of the geotextile and the furthest seam edge.

3.1.5.1 *Discussion*—In geotextiles, the distance from the selvege or turned edge of the geotextile to the edge of the seam.

3.1.6 *seam assembly, n*—the unit obtained by joining geotextile with a seam, including details such as geotextile direction(s), seam allowance, seam width, seam type, speed, and if sewn—sewing threads used and number of stitches per unit length, needle type and size, and so forth.

3.1.7 *seam efficiency, n*—the ratio expressed as a percentage of seam strength to geotextile strength.

3.1.8 *seam design engineering, n*—the procedures used to select a specific thread, a specific stitch type, and a specific seam type to achieve the required seam strength of a sewn seam and the procedures used to select a specific seam width, specific seam bonding temperature, and a specific seam speed and pressure to achieve the required seam strength of a thermally bonded seam.

3.1.9 *seam interaction, n*—the result of combining specific textile, a specific stitch type, and a specific seam type for a

⁴ *Annual Book of ASTM Standards*, Vol 14.02.

⁵ Available from Standardization Documents Order Desk, Bldg. 4 Section D, 700 Robbins Ave., Philadelphia, PA 19111-5094, Attn: NPODS.

sewn seam and the result of combining specific textile, a specific seam width, a specific seam speed, and applied pressure for a thermally bonded seam.

3.1.10 *seam type, n*—in sewn geotextiles, an alphanumeric designation relating to the essential characteristics of geotextile positioning and rows of stitching in a specific sewn geotextile seam (see Fed. Std. No. 751a).

3.1.10.1 *Discussion*—The first two letters of the designation show seam type; the third and subsequent letter specify a particular mating alignment; the number designation indicates the number of rows of stitches.

3.1.11 *seam weld, n*—the process by which a seam is formed through the thermal bonding of separate layers of geotextile.

3.1.12 *selvage, n*—the woven edge portion of a geotextile parallel to the machine direction.

3.1.12.1 *Discussion*—The edge of a nonwoven geotextile cannot be easily distinguished to determine either the machine or cross-machine direction.

3.1.13 *sewing thread, n*—a flexible, small diameter yarn or strand, usually treated with a surface coating, or lubricant, or both, intended to be used to stitch one or more pieces of material or an object to a material.

3.1.14 *sewn seam, n*—in sewn geotextiles, a series of stitches joining two or more separate plies of a material or materials of planar structure such as a textile geotextile.

3.1.15 *sewn seam strength, n*—for geotextiles, the maximum resistance, measured in kilonewtons per metre, of the junction formed by stitching together two or more planar structures.

3.1.16 *stitch, n*—the repeated unit formed by the sewing thread in the production of seams in a sewn geotextile (see Fed. Std. No. 751a).

3.1.17 *tensile strength, n*—the maximum resistance of material to deformation in a tensile test carried to rupture; that is, the breaking load, or force per unit cross-sectional area of the unstrained specimen.

3.1.18 *thermally bonded seam, n*—in geotextiles, a seam made by the application of thermal energy.

3.1.19 *thermally bonded seam strength, n*—for geotextiles, the maximum shear resistance, measured in kilonewtons per metre, of the junction formed by thermally bonding together two or more planar structures.

3.1.20 For definitions of other terms relating to textiles, refer to Terminology D 123. For definitions of other terms relating to geotextiles, refer to Terminology D 4439.

4. Summary of Test Method

4.1 A seam, 200 mm (8 in.) wide is gripped across the entire width in the clamps of a tensile testing machine, operated at a prescribed rate of extension, applying a longitudinal (perpendicular) force to the specimen until the seam or geotextile ruptures.

5. Significance and Use

5.1 As explained in Test Method D 4595, narrow geotextile specimens demonstrate the tendency to contract (neck down) in the gage area when under stress. The wider width specimen will minimize this phenomenon in seams during strength

testing. The results achieved in this test method can more accurately correlate to the seam strength values anticipated in the field.

5.2 This test method can be used to measure the seam strength of geotextiles, and may also be used for acceptance testing of commercial shipments of geotextiles. When strength is not necessarily a design consideration of seam interaction, an alternate method for determining the seam strength, such as Test Method D 1683, may be used depending on the specification requirements. Because current information about laboratory precision is incomplete, comparative tests, as described in 5.2.1, may be advisable.

5.2.1 In case of a dispute arising from differences in reported test results when using this test method for acceptance testing of commercial shipments, the purchaser and the supplier should perform comparative tests to determine if there is a statistical bias between their laboratories. Competent statistical assistance is recommended for the investigation of bias. As a minimum, the two parties should take a group of test specimens from the same lot of geotextile, that utilize a like method of seam assembly to achieve seam interaction. The specimens should then be randomly assigned in equal number to each laboratory for testing. If a bias is found, either its cause must be determined and corrected, or the purchaser and the supplier must agree to interpret future test results in light of the known bias.

5.3 Although other methods of determining seam strength are available, this test method, that measures wide specimens, will more accurately correlate to the anticipated performance in the field.

5.4 This test method can be used to help determine seam design engineering for the geotextiles being evaluated.

6. Apparatus

6.1 *Tensile Testing Machine*, must be of the constant-rate-of-extension (CRE) type, conforming to Specification D 76 and equipped with a recorder having an adequate pen response or interfaced computer to record the load elongation curve. The machine must be set to a rate of extension of $10 \pm 3\%$ /min.

6.2 *Clamps*—The clamps shall be wide enough to grip the entire width of the specimen and have the appropriate clamping power to hold the test specimen in place without crushing (damaging) the machine direction and cross-machine direction yarns.

6.2.1 Caution must be taken to ensure that the type of clamp used is adequate for the seam strength being measured.

6.3 *Size of Jaw Faces*—Each clamp shall have a bearing face measuring wider than the width of the specimen, 200 mm (8 in.) and a minimum of 50 mm (2 in.) in length, in the direction of the applied force. The size of jaw faces does not apply if roller clamps are used.

7. Sampling for Acceptance Testing and Number of Specimens

7.1 *Division into Lots and Lot Sample*—Divide the material into lots and take a lot sample as described in an applicable material specification, or as agreed upon between the purchaser and the supplier. In the absence of an applicable material specification or prior agreement between the purchaser and the

supplier, sampling and testing intervals should be agreed upon between the purchaser and the supplier.

7.1.1 When the installation project requires that seams are made in both the machine and cross-machine directions, the number of samples and the subsequent specimens will increase proportionately.

7.2 *Laboratory Samples*—At a laboratory sample, cut a minimum of two swatches of geotextile from each of the lot units selected for testing. The swatches must be a minimum of 2000 mm (79 in.) in length and a minimum of 300 mm (12 in.) in width. The lengthwise direction of these swatches must be cut from opposite ends and opposite sides of the lot sample rolls and should be parallel to the direction in which the seam will be made.

7.2.1 When seams are made in both the machine and cross-machine direction, it is suggested that some type of special color identification marking be used to distinguish one from the other.

7.2.2 These swatches are then joined using the best seam engineering techniques determined by the purchaser and the supplier to achieve seam interaction.

7.2.3 It will be necessary to cut a sufficient number of swatches for both wet and conditioned tests.

7.3 Test Specimens:

7.3.1 *Number of Specimens*—In the absence of an applicable specification or prior agreement between the purchaser and the supplier, prepare at least six test specimens from the laboratory samples.

7.3.2 *Test Specimen Size*—Prepare test specimens from the laboratory sample. Each specimen should be approximately 250 mm (10 in.) wide with a stitch line in the center for sewn seams or approximately 200 mm (8 in.) wide with the seam weld in the center for thermally bonded seams running parallel to either the machine or cross-machine directions as shown in Fig. 1(a) for sewn seams or Fig. 1(b) for thermally bonded seams.

7.3.2.1 Cut this wider specimen for sewn seams as shown in Fig. 1(a) to achieve a final test specimen width of 200 mm (8 in.). When removing the shaded area from a specimen as shown in Fig. 1(a), the angles between the 25-mm extensions which are parallel to the seam and that section of the specimen having a finished width of 200 mm is 90°.

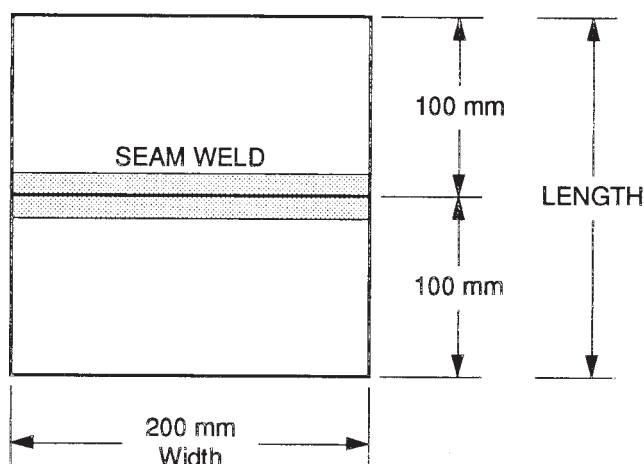

FIG. 1 (b) Test Specimen Preparation for Thermally Bonded Seam (Front View) (continued)

8. Sampling of Field Seams and Factory Seams

8.1 The evaluation of field seams and factory seams will be made by taking samples at the stipulated intervals directed in Table 1 unless otherwise stated.

NOTE 1—To prevent the unnecessary waste of geotextile or impede the installation, it should be agreed upon between the supplier and the purchaser that all seam samples can be taken from alternate sides of panels at or near the end of the rolls.

8.2 The lengthwise direction of these swatches should be parallel to the direction of the seam, either in the machine or cross-machine direction.

8.2.1 It will be necessary to cut additional swatches for both wet and conditioned tests to be performed.

8.3 Prepare test specimens as specified in Section 7, 7.3.2, and, if sewn, 7.3.2.1.

9. Conditioning

9.1 Bring the specimens to moisture equilibrium in the atmosphere for testing geotextiles. Equilibrium is considered to have been reached when the increase in mass of the specimen in successive weighings made at intervals of not less than 2 h does not exceed 0.1 % of the mass of the specimen. Unless the purchaser and the supplier agree otherwise, bring the test specimens to moisture equilibrium starting with the condition in which they were received.

9.1.1 Certain fibers may exhibit slow moisture equalization rates when received in a wet condition. When this is known, the purchaser and the supplier may agree to use a preconditioning cycle as specified in Practice D 1776.

TABLE 1 Seam Quality Control Sampling Requirements

Total Length of Field ^A Seams for Project, m (yd)	Sample Interval ^B Requirements, m (yd)
Up to 10 000 (Up to 11 000)	1000 (1100)
10 001 to 150 000 (11 000 to 165 000)	1500 (1666)
150 000 and up (165 000 and up)	2000 (2200)

^A Total length of field seams for project is the sum of all machine direction and cross-machine direction seams required to effect installation of geotextile(s).

^B Samples will be taken at stipulated intervals along the total length of the field seams. The number of such intervals will be rounded to the next higher whole number.

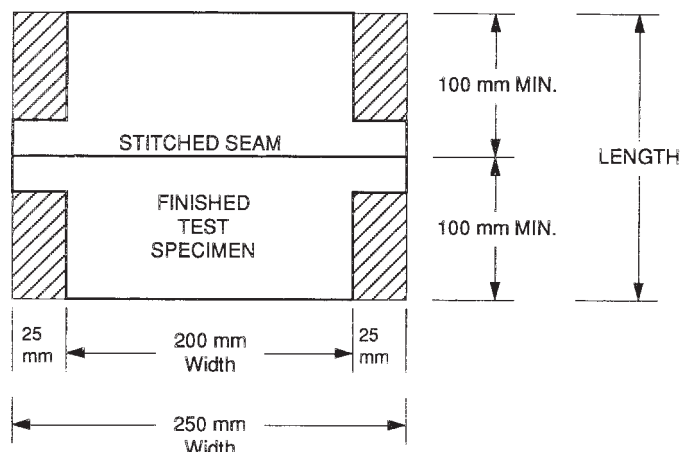

FIG. 1 (a) Test Specimen Preparation for Sewn Seam (Front View)