**Tool holders for internal turning
with cylindrical shank for indexable
inserts —**

**Part 2:
Style F**

iTeh STANDARD PREVIEW
*Porte-plaquette de tournage intérieur à queue cylindrique pour
plaquettes amovibles —
(standards.iteh.ai)
Partie 2: Forme F*

ISO 5609-2:2012

<https://standards.iteh.ai/catalog/standards/sist/335be8dc-570c-487d-97dd-7d48f98df7f6/iso-5609-2-2012>



iTeh STANDARD PREVIEW
(standards.iteh.ai)

ISO 5609-2:2012

<https://standards.iteh.ai/catalog/standards/sist/335be8dc-570c-487d-97dd-7d48f98df7f6/iso-5609-2-2012>



COPYRIGHT PROTECTED DOCUMENT

© ISO 2012

All rights reserved. Unless otherwise specified, no part of this publication may be reproduced or utilized in any form or by any means, electronic or mechanical, including photocopying and microfilm, without permission in writing from either ISO at the address below or ISO's member body in the country of the requester.

ISO copyright office
Case postale 56 • CH-1211 Geneva 20
Tel. + 41 22 749 01 11
Fax + 41 22 749 09 47
E-mail copyright@iso.org
Web www.iso.org

Published in Switzerland

Contents

	Page
Foreword	iv
1 Scope	1
2 Normative references	1
3 Dimensions	1
3.1 General dimensions	1
3.2 Tool holder, style F, for rhombic indexable, shape C	2
3.3 Tool holder, style F, for triangular indexable insert, shape T	3
4 Designation	4
5 Material	5
6 Design	5
6.1 Type of tool	5
6.2 Type of mounting	5
6.3 Corner radius r_ϵ	5
6.4 Thickness, s , of insert	6
7 Extent of delivery	6
8 Marking	6
Bibliography	7

iTeh STANDARD PREVIEW
(standards.iteh.ai)

[ISO 5609-2:2012](https://standards.iteh.ai/catalog/standards/sist/335be8dc-570c-487d-97dd-7d48f98df7f6/iso-5609-2-2012)

<https://standards.iteh.ai/catalog/standards/sist/335be8dc-570c-487d-97dd-7d48f98df7f6/iso-5609-2-2012>

Foreword

ISO (the International Organization for Standardization) is a worldwide federation of national standards bodies (ISO member bodies). The work of preparing International Standards is normally carried out through ISO technical committees. Each member body interested in a subject for which a technical committee has been established has the right to be represented on that committee. International organizations, governmental and non-governmental, in liaison with ISO, also take part in the work. ISO collaborates closely with the International Electrotechnical Commission (IEC) on all matters of electrotechnical standardization.

International Standards are drafted in accordance with the rules given in the ISO/IEC Directives, Part 2.

The main task of technical committees is to prepare International Standards. Draft International Standards adopted by the technical committees are circulated to the member bodies for voting. Publication as an International Standard requires approval by at least 75 % of the member bodies casting a vote.

Attention is drawn to the possibility that some of the elements of this document may be the subject of patent rights. ISO shall not be held responsible for identifying any or all such patent rights.

ISO 5609-2 was prepared by Technical Committee ISO/TC 29, *Small tools*, Subcommittee SC 9, *Tools with cutting edges made of hard cutting materials*.

This first edition of ISO 5609-2, together with ISO 5609-1, ISO 5609-3, ISO 5609-4, ISO 5609-5 and ISO 5609-6, cancels and replaces ISO 5609:1998, which has been technically revised.

ISO 5609 consists of the following parts, under the general title *Tool holders for internal turning with cylindrical shank for indexable inserts*:

Part 1: Designation, styles, dimensions and calculation for corrections

Part 2: Style F

Part 3: Style K

Part 4: Style L

Part 5: Style U

Part 6: Style Q

<https://standards.iteh.ai/catalog/standards/sist/335be8dc-570c-487d-97dd-7d48f98df7f6/iso-5609-2-2012>

Tool holders for internal turning with cylindrical shank for indexable inserts —

Part 2: Style F

1 Scope

This part of ISO 5609 specifies the characteristics of tool holders for internal turning with cylindrical shank, style F, i.e. with reduced shank and cutting edge angle $\kappa_r = 90^\circ$.

These tool holders are primarily intended for indexable inserts made of hardmetal, ceramic or other cutting materials to be mounted by clamping and to be used for internal turning operations.

2 Normative references

The following documents, in whole or in part, are normatively referenced in this document and are indispensable for its application. For undated references, the latest edition of the referenced document (including any amendments) applies.

ISO 5609-1, *Tool holders for internal turning with cylindrical shank for indexable inserts — Part 1: Designation, styles, dimensions and calculation for corrections*

[ISO 5609-2:2012](https://standards.iteh.ai/catalog/standards/sist/335be8dc-570c-487d-97dd-7d48f98df7f6/iso-5609-2-2012)

3 Dimensions

<https://standards.iteh.ai/catalog/standards/sist/335be8dc-570c-487d-97dd-7d48f98df7f6/iso-5609-2-2012>

3.1 General dimensions

The symbols for dimensions shown in the figures/illustrations in the tables of this part of ISO 5609 and the corresponding preferred symbols of properties defined in ISO 13399 (all parts) are in accordance with Table A.1 of ISO 5609-1:2012.

The tool holders need not comply with the pictorial representation; only the dimensions given shall be observed.

The determination of dimensions, f and l_1 and an explanation of the designation code for tool holders are given in ISO 5609-1.

3.2 Tool holder, style F, for rhombic indexable, shape C

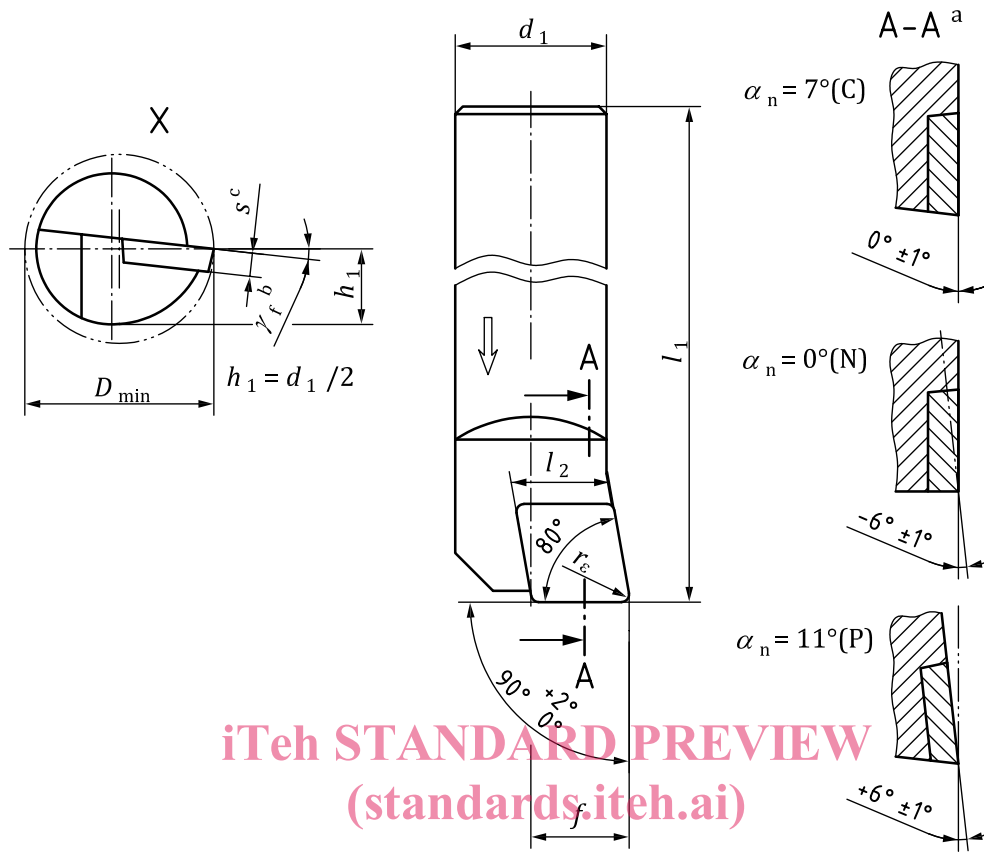

iTeh STANDARD PREVIEW
(standards.iteh.ai)

ISO 5609-2:2012

<https://standards.iteh.ai/catalog/standards/sist/335be8dc-570c-487d-97dd-7d48f98df7f8/iso-5609-2-2012>

NOTE This figure shows a right-hand tool holder (R); left-hand tool holder (L) laterally reversed.

a Orthogonal rake angle, γ_o , with indexable insert for:

- $\alpha_n = 7^\circ$ (C);
- $\alpha_n = 0^\circ$ (N);
- $\alpha_n = 11^\circ$ (P).

b γ_f is dependent on D_{min} and the indexable insert.

c See Table 1.

Figure 1 — Tool holder, style F, for rhombic indexable insert, shape C

Table 1 —

Dimensions in millimetres

Symbol ^a	d_1	l_1	l_2	f	D_{min}	s^b
		g7	k16	≈	$\begin{matrix} 0 \\ -0,25 \end{matrix}$	
<ul style="list-style-type: none"> • 08F — SCFCR 06 • 08F — SCFCL 06 	8	80	6,4	6	11	2,38
<ul style="list-style-type: none"> • 10H — SCFCR 06 • 10H — SCFCL 06 	10	100	6,4	7	13	2,38

^a For the supplementary symbol, see 6.1.

^b For indexable insert thickness without shim, if any, see 6.4.

3.3 Tool holder, style F, for triangular indexable insert, shape T

For other dimensions and details, see Figure 1.

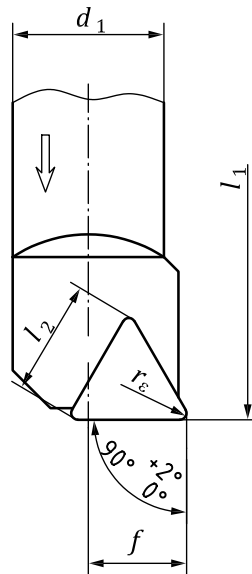

NOTE This figure shows a right-hand tool holder (R); left hand tool holder (L) laterally reversed.

Figure 2 — Tool holder, style F, for triangular indexable insert, shape T

(standards.iteh.ai)

Table 2 —

ISO 5609-2:2012

Dimensions in millimetres

Symbol ^a	d_1	l_1	l_2	f	D_{min}	s^b
	g7	k16	≈	$\begin{matrix} 0 \\ -0,25 \end{matrix}$		
· 10H — STFCR 11 · 10H — STFCL 11	10	100	11,0	7	13	2,38
· 12K — STFCR 11 · 12K — STFCL 11	12	125	11,0	9	16	2,38
· 16M — STFCR 11 · 16M — STFCL 11	16	150	11,0	11	20	2,38
· 16M — CTFPR 11 · 16M — CTFPL 11						3,18
· 20Q — STFCR 16 · 20Q — STFCL 16	20	180	16,5	13	25	3,97
· 20Q — CTFPR 16 · 20Q — CTFPL 16						3,18
· 25R — STFCR 16 · 25R — STFCL 16	25	200	16,5	17	32	3,97
· 25R — CTFPR 16 · 25R — CTFPL 16						3,18

Table 2 (continued)

Symbol ^a	d_1	l_1	l_2	f	D_{\min}	s^b	
	g7	k16	≈	0 -0,25			
• 32S — STFCR 16 • 32S — STFCL 16	32	250	16,5	22	40	3,97	
• 32S — PTFNR 16 • 32S — PTFNL 16						4,76	
• 32S — CTFPR 16 • 32S — CTFPL 16						3,18	
• 40T — STFCR 16 • 40T — STFCL 16	40	300	16,5	27	50	3,97	
• 40T — PTFNR 16 • 40T — PTFNL 16						4,76	
• 40T — CTFPR 16 • 40T — CTFPL 16						3,18	
• 40T — STFCR 22 • 40T — STFCL 22			22			4,76	
• 40T — PTFNR 22 • 40T — PTFNL 22							
• 40T — CTFPR 22 • 40T — CTFPL 22							
• 50U — STFCR 22 • 50U — STFCL 22	50	350	22,0	35	63		4,76
• 50U — PTFNR 22 • 50U — PTFNL 22							
• 50U — CTFPR 22 • 50U — CTFPL 22							
• 60V — STFCR 22 • 60V — STFCL 22	60	400	22,0	43	80	4,76	
• 60V — PTFNR 22 • 60V — PTFNL 22							
• 60V — CTFPR 22 • 60V — CTFPL 22							

iTeh STANDARD PREVIEW
(standards.iteh.ai)

ISO 5609-2:2012
<https://standards.iteh.ai/catalog/standards/sist/335bc8dc-570c-487d-97dd-7d48f98df7f5/iso-5609-2-2012>

^a and ^b See Table 1.

4 Designation

A tool holder in accordance with this part of ISO 5609 shall be designated by:

- a) “Tool holder”;
- b) reference to this part of ISO 5609, i. e. ISO 5609-2;
- c) additional designation symbol as specified in ISO 5609-1:2012, Clause 4.

EXAMPLE 1 Tool holder for internal turning with cylindrical shank with solid steel tool (S), with a diameter of shank $d_1 = 10$ mm (10), length $l_1 = 100$ mm (H), for screw clamping through hole (S) rhombic indexable insert with included angle $\epsilon_r = 80^\circ$ (C), style F (F), for indexable insert normal clearance $\alpha_n = 7^\circ$ (C), right-hand type (R), for cutting edge length $l_2 = 6,4$ mm (06) and round shank without flats is designated as follows:

Tool holder ISO 5609-2 - S10H - SCFCR 06 - 10

EXAMPLE 2 Tool holder for internal turning with cylindrical shank with solid steel tool with lubrication hole (A), diameter of the shank $d_1 = 32$ mm (32), length $l_1 = 250$ mm (S), top clamping (C) triangular indexable insert (T), style F (F), for indexable insert normal clearance $\alpha_n = 11^\circ$ (P), right-hand type (R), for cutting edge length $l_2 = 16,5$ mm (16)) and round shank without 4 flats is designated as follows:

Tool holder ISO 5609-2 - A32S - CTFPR 16 - 41

5 Material

Tool holders for internal turning with cylindrical shank in accordance with this standard shall be made from steel with a tensile strength of at least 1 000 N/mm²,
hardmetal (carbide) tool with brazed steel head, or
heavy metal tool.

The material should be left to the manufacturer's discretion.

6 Design

6.1 Type of tool

Tool holders for internal turning with cylindrical shank in accordance with this part of ISO 5609 are designed:

with or without lubrication hole;

with or without antivibration device;

hardmetal (carbide) tool with brazed steel head.

The design of the type of tool should be left to the manufacturer's discretion.

6.2 Type of mounting

The standard design of tool holders with indexable insert shall be mounted in accordance with Tables 1 and 2.

Other types of mounting may be at the manufacturer's discretion or upon agreement. The letter symbol in the designation (symbol 4) shall then be replaced by the respective symbol for the chosen or agreed type of mounting in accordance with ISO 5609-1.

For the modified type of mounting deviating from Tables 1 and 2, the relevant insert thickness shall also be considered.

6.3 Corner radius r_ϵ

Tool holders with cylindrical shank in accordance with this part of ISO 5609 may be equipped with indexable inserts with cutting edge lengths, l_2 , as specified in Tables 1 and 2 and any corner radius r_ϵ .

The values for f and l_1 given in Tables 1 and 2 apply to tool holders with indexable inserts having corner radii, r_ϵ , in accordance with Table 3.