**Tool holders for internal turning
with cylindrical shank for indexable
inserts —**

**Part 4:
Style L**

iTeh STANDARD PREVIEW
*Porte-plaquette de tournage intérieur à queue cylindrique pour
plaquettes amovibles —
(standards.iteh.ai)
Partie 4: Forme L*

ISO 5609-4:2012

<https://standards.iteh.ai/catalog/standards/sist/aflcabb-3105-437d-ba26-b054c7a1ae77/iso-5609-4-2012>



iTeh STANDARD PREVIEW
(standards.iteh.ai)

ISO 5609-4:2012

<https://standards.iteh.ai/catalog/standards/sist/a1eabb-3105-437d-ba26-b054c7a1ae77/iso-5609-4-2012>



COPYRIGHT PROTECTED DOCUMENT

© ISO 2012

All rights reserved. Unless otherwise specified, no part of this publication may be reproduced or utilized in any form or by any means, electronic or mechanical, including photocopying and microfilm, without permission in writing from either ISO at the address below or ISO's member body in the country of the requester.

ISO copyright office
Case postale 56 • CH-1211 Geneva 20
Tel. + 41 22 749 01 11
Fax + 41 22 749 09 47
E-mail copyright@iso.org
Web www.iso.org

Published in Switzerland

Contents

	Page
Foreword	iv
1 Scope	1
2 Normative references	1
3 Dimensions	1
3.1 General	1
3.2 Tool holder, style L, for rhombic indexable insert, shape C	2
3.3 Tool holder, style L, for hexagonal indexable insert, shape W	4
4 Designation	5
5 Material	5
6 Design	6
6.1 Type of tool	6
6.2 Type of mounting	6
6.3 Corner radius r_ϵ	6
6.4 Thickness, s , of insert	7
7 Extent of delivery	7
8 Marking	7
Bibliography	8

iTeh STANDARD PREVIEW
(standards.iteh.ai)

ISO 5609-4:2012

<https://standards.iteh.ai/catalog/standards/sist/afl eabbb-3105-437d-ba26-b054c7a1ae77/iso-5609-4-2012>

Foreword

ISO (the International Organization for Standardization) is a worldwide federation of national standards bodies (ISO member bodies). The work of preparing International Standards is normally carried out through ISO technical committees. Each member body interested in a subject for which a technical committee has been established has the right to be represented on that committee. International organizations, governmental and non-governmental, in liaison with ISO, also take part in the work. ISO collaborates closely with the International Electrotechnical Commission (IEC) on all matters of electrotechnical standardization.

International Standards are drafted in accordance with the rules given in the ISO/IEC Directives, Part 2.

The main task of technical committees is to prepare International Standards. Draft International Standards adopted by the technical committees are circulated to the member bodies for voting. Publication as an International Standard requires approval by at least 75 % of the member bodies casting a vote.

Attention is drawn to the possibility that some of the elements of this document may be the subject of patent rights. ISO shall not be held responsible for identifying any or all such patent rights.

ISO 5609-4 was prepared by Technical Committee ISO/TC 29, *Small tools*, Subcommittee SC 9, *Tools with cutting edges made of hard cutting materials*.

This first edition of ISO 5609-4, together with ISO 5609-1, ISO 5609-2, ISO 5609-3, ISO 5609-5 and ISO 5609-6, cancels and replaces ISO 5609:1998, which has been technically revised.

ISO 5609 consists of the following parts, under the general title *Tool holders for internal turning with cylindrical shank for indexable inserts*:

Part 1: Designation, styles, dimensions and calculation for corrections

Part 2: Style F

Part 3: Style K

Part 4: Style L

Part 5: Style U

Part 6: Style Q

<https://standards.iteh.ai/catalog/standards/sist/afl eabbb-3105-437d-ba26-b054c7a1ae77/iso-5609-4-2012>

Tool holders for internal turning with cylindrical shank for indexable inserts —

Part 4: Style L

1 Scope

This part of ISO 5609 specifies the characteristics of tool holders for internal turning with cylindrical shank, style L, i.e. with reduced shank and cutting edge angle $\kappa_r = 95^\circ$.

These tool holders are primarily intended for indexable inserts made of hardmetal, ceramic or other cutting materials to be mounted by clamping and to be used for internal turning operations.

2 Normative references

The following documents, in whole or in part, are normatively referenced in this document and are indispensable for its application. For undated references, the latest edition of the referenced document (including any amendments) applies.

ISO 5609-1, *Tool holders for internal turning with cylindrical shank for indexable inserts — Part 1: Designation, styles, dimensions and calculation for corrections*

[ISO 5609-4:2012](https://standards.iteh.ai/catalog/standards/sist/a1eabb-3105-437d-ba26-b054c7a1ae77/iso-5609-4-2012)

3 Dimensions

<https://standards.iteh.ai/catalog/standards/sist/a1eabb-3105-437d-ba26-b054c7a1ae77/iso-5609-4-2012>

3.1 General

The symbols for dimensions shown in the figures/illustrations in the tables of this part of ISO 5609 and the corresponding preferred symbols of properties defined in ISO 13399 (all parts) are in accordance with Table A.1 of ISO 5609-1:2012.

The tool holders need not comply with the pictorial representation; only the dimensions given shall be observed.

The determination of dimensions f and l_1 and explanation of the designation code for tool holders are given in ISO 5609-1.

3.2 Tool holder, style L, for rhombic indexable insert, shape C

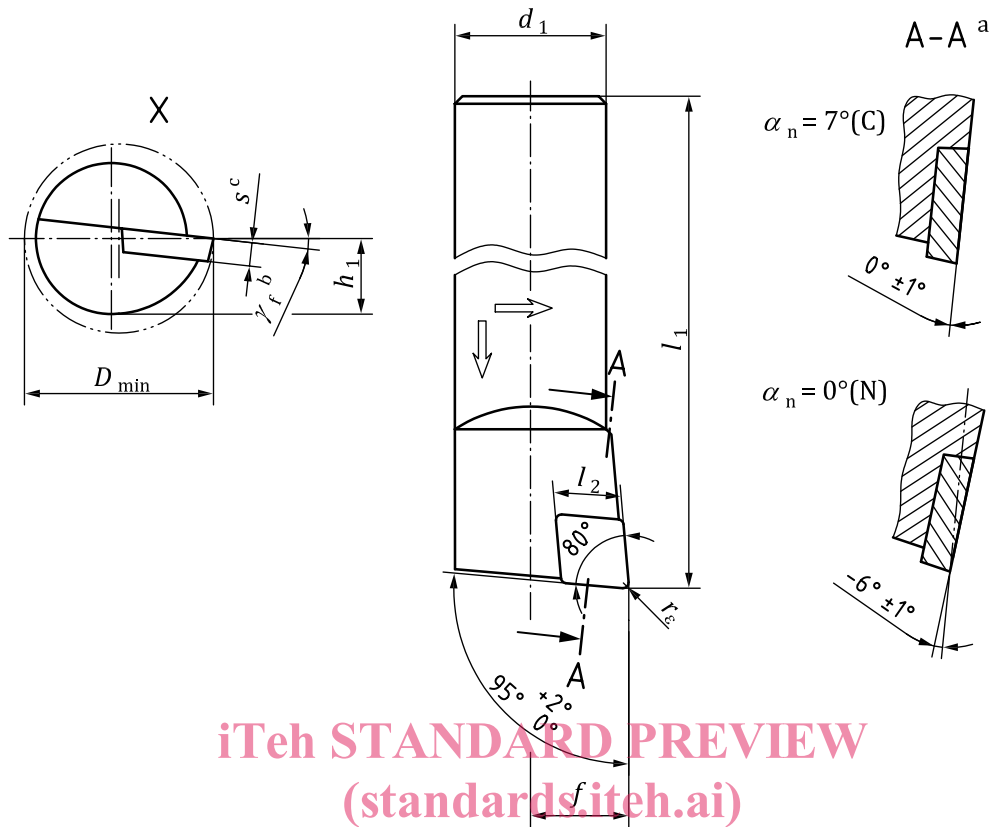

iTeh STANDARD PREVIEW
(standards.iteh.ai)

ISO 5609-4:2012

<https://standards.iteh.ai/catalog/standards/sist/aflcabb-3105-437d-ba26-b054c7a1ae77/iso-5609-4-2012>

NOTE This figure shows a right-hand tool holder (R); left-hand tool holder (L) laterally reversed.

a Orthogonal rake angle, γ_o , with indexable insert for:

— $\alpha_n = 7^\circ$ (C);

— $\alpha_n = 0^\circ$ (N).

b γ_f is dependent on D_{min} and the indexable insert.

c See Table 1.

Figure 1 — Tool holder, style L, for rhombic indexable insert, shape C

Table 1 —

Dimensions in millimetres

Symbol ^a	d_1	l_1	l_2	f	D_{min}	s^b
	g7	k16	≈	$\begin{matrix} 0 \\ -0,25 \end{matrix}$		
• 08F — SCLCR 06 • 08F — SCLCL 06	8	80	6,4	6	11	2,38
• 10H — SCLCR 06 • 10H — SCLCL 06	10	100	6,4	7	13	2,38
• 12K — SCLCR 06 • 12K — SCLCL 06	12	125	6,4	9	16	2,38
• 16M — SCLCR 09 • 16M — SCLCL 09	16	150	9,7	11	20	3,97

Table 1 (continued)

Symbol ^a	d_1	l_1	l_2	f	D_{\min}	s^b
	g7	k16	≈	$\begin{matrix} 0 \\ -0,25 \end{matrix}$		
· 20Q — SCLCR 09 · 20Q — SCLCL 09	20	180	9,7	13	25	3,97
· 25R — SCLCR 12 · 25R — SCLCL 12	25	200	12,9	17	32	4,76
· 32S — SCLCR 12 · 32S — SCLCL 12	32	250	12,9	22	40	4,76
· 32S — PCLNR 12 · 32S — PCLNL 12						
· 40T — SCLCR 12 · 40T — SCLCL 12	40	300	12,9	27	50	4,76
· 40T — PCLNR 12 · 40T — PCLNL 12						
· 50U — PCLNR 16 · 50U — PCLNL 16	50	350	16,1	35	63	6,35
· 50U — PCLNR 19 · 50U — PCLNL 19			19,3			6,35
· 60V — PCLNR 16 · 60V — PCLNL 16	60	400	16,1	43	80	6,35
· 60V — PCLNR 19 · 60V — PCLNL 19			19,3			6,35

^a For supplementary symbol, see 6.1. [ISO 5609-4:2012](#)

^b For indexable insert thickness without shim, if any, see 6.4. <https://standards.iteh.ai/catalog/standards/sist/a1eabbh-3105-437d-ba26-b054c7a1ac77/iso-5609-4-2012>

3.3 Tool holder, style L, for hexagonal indexable insert, shape W

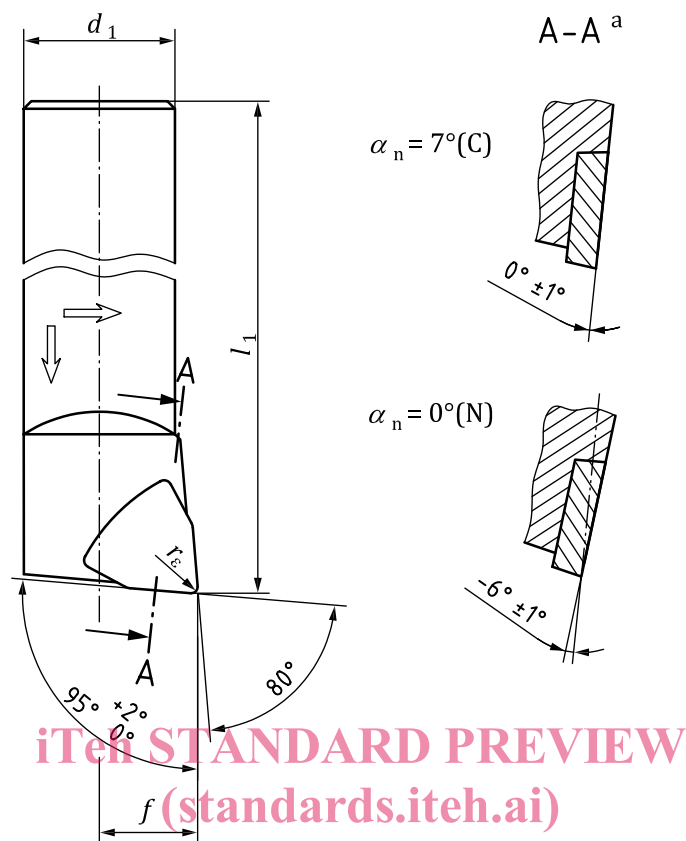

NOTE This figure shows a right-hand tool holder (R); left-hand tool holder (L) laterally reversed.

a Inclination angle, λ_n , with indexable insert for:

- $\alpha_n = 7^\circ$ (C);
- $\alpha_n = 0^\circ$ (N).

Figure 2 — Tool holder, style L, for hexagonal indexable insert, shape W

Table 2 —

Dimensions in millimetres

Symbol ^a	d_1	l_1	l_2	f	D_{\min}	s^b
	g7	k16	≈	$\begin{matrix} 0 \\ -0,25 \end{matrix}$		
· 08F — SWLCR L3 · 08F — SWLCL L3	8	80	3,26	6	11	1,98
· 10H — SWLCR 04 · 10H — SWLCL 04	10	100	4,34	7	13	2,38
· 12K — SWLCR 04 · 12K — SWLCL 04	12	125	4,34	9	16	2,38
· 16M — SWLCR 04 · 16M — SWLCL 04	16	150	4,34	11	20	2,38
· 16M — SWLCR 06 · 16M — SWLCL 06			6,52			3,97
· 20Q — SWLCR 06 · 20Q — SWLCL 06	20	180	6,52	13	25	3,97

Table 2 (continued)

Symbol ^a	d_1	l_1	l_2	f	D_{\min}	s^b
	g7	k16	≈	$\begin{matrix} 0 \\ -0,25 \end{matrix}$		
· 25R — SWLCR 06 · 25R — SWLCL 06	25	200	6,52	17	32	3,97
· 25R — SWLCR 08 · 25R — SWLCL 08			8,69			4,76
· 32S — SWLCR 06 · 32S — SWLCL 06	32	250	6,52	22	40	3,97
· 32S — SWLCR 08 · 32S — SWLCL 08			8,69			4,76
· 40T — SWLCR 06 · 40T — SWLCL 06	40	300	6,52	27	50	3,97
· 40T — SWLCR 08 · 40T — SWLCL 08			8,69			4,76

^a and ^b See Table 1.

4 Designation

A tool holder in accordance with this part of ISO 5609 shall be designated by:

- “Tool holder”;
- reference to this part of ISO 5609, i. e. ISO 5609-4;
- additional designation symbol, as specified in ISO 5609-1:2012, Clause 4.

EXAMPLE 1 Tool holder for internal turning with cylindrical shank with solid steel tool with lubrication hole (A), diameter $d_1 = 32$ mm (32), length $l_1 = 250$ mm (S), for screw clamping through hole (S) rhombic indexable insert with included angle $\varepsilon_r = 80^\circ$ (C), style L (L), for indexable insert normal clearance $\alpha_n = 7^\circ$ (C), right-hand type (R), for cutting edge length $l_2 = 12,9$ mm (12) and round shank without flats is designated as follows:

Tool holder ISO 5609-4 - A32S - SCLCR 12 - 10

EXAMPLE 2 Tool holder for internal turning with cylindrical shank with solid steel tool with lubrication hole (A), diameter $d_1 = 25$ mm (25), length $l_1 = 200$ mm (R), for screw clamping through hole (S) hexagonal indexable insert with 80° included angle (W), style L (L), for indexable insert normal clearance $\alpha_n = 7^\circ$ (C), right hand type (R), for cutting edge length $l_2 = 6,52$ mm (06) and round shank without 4 flats is designated as follows:

Tool holder ISO 5609-4 - A25S - SWLCR 06 - 41

5 Material

Tool holders for internal turning with cylindrical shank in accordance with this part of ISO 5609 shall be made from

- steel with a tensile strength of a least 1 000 N/mm²,
- hardmetal (carbide) tool with brazed steel head, or
- heavy metal tool.

The material should be left to the manufacturer's discretion.