**Textiles — Bare elastane yarns
— Determination of resistance to
chlorinated water (swimming-pool
water)**

*Textiles — Fils d'élasthane nu — Détermination de la résistance à
l'eau chlorée (eau de piscine)*

iTeh STANDARD PREVIEW
(standards.iteh.ai)

[ISO 17608:2015](https://standards.iteh.ai/catalog/standards/sist/ccc4ad22-68ff-45fd-b5b5-abca63eafc82/iso-17608-2015)

[https://standards.iteh.ai/catalog/standards/sist/ccc4ad22-68ff-45fd-b5b5-
abca63eafc82/iso-17608-2015](https://standards.iteh.ai/catalog/standards/sist/ccc4ad22-68ff-45fd-b5b5-abca63eafc82/iso-17608-2015)



iTeh STANDARD PREVIEW
(standards.iteh.ai)

ISO 17608:2015

<https://standards.iteh.ai/catalog/standards/sist/ccc4ad22-68ff-45fd-b5b5-abca63eafc82/iso-17608-2015>



COPYRIGHT PROTECTED DOCUMENT

© ISO 2015, Published in Switzerland

All rights reserved. Unless otherwise specified, no part of this publication may be reproduced or utilized otherwise in any form or by any means, electronic or mechanical, including photocopying, or posting on the internet or an intranet, without prior written permission. Permission can be requested from either ISO at the address below or ISO's member body in the country of the requester.

ISO copyright office
Ch. de Blandonnet 8 • CP 401
CH-1214 Vernier, Geneva, Switzerland
Tel. +41 22 749 01 11
Fax +41 22 749 09 47
copyright@iso.org
www.iso.org

Contents		Page
Foreword		iv
1 Scope		1
2 Normative references		1
3 Terms and definition		1
4 Principle		1
5 Apparatus		2
6 Reagents		3
7 Conditioning and testing atmosphere		4
8 Preparing test specimens		4
9 Testing procedure		4
10 Results		6
11 Test report		6
Bibliography		7

iTeh STANDARD PREVIEW
(standards.iteh.ai)

[ISO 17608:2015](https://standards.iteh.ai/catalog/standards/sist/ccc4ad22-68ff-45fd-b5b5-abca63eafc82/iso-17608-2015)

<https://standards.iteh.ai/catalog/standards/sist/ccc4ad22-68ff-45fd-b5b5-abca63eafc82/iso-17608-2015>

Foreword

ISO (the International Organization for Standardization) is a worldwide federation of national standards bodies (ISO member bodies). The work of preparing International Standards is normally carried out through ISO technical committees. Each member body interested in a subject for which a technical committee has been established has the right to be represented on that committee. International organizations, governmental and non-governmental, in liaison with ISO, also take part in the work. ISO collaborates closely with the International Electrotechnical Commission (IEC) on all matters of electrotechnical standardization.

The procedures used to develop this document and those intended for its further maintenance are described in the ISO/IEC Directives, Part 1. In particular the different approval criteria needed for the different types of ISO documents should be noted. This document was drafted in accordance with the editorial rules of the ISO/IEC Directives, Part 2 (see www.iso.org/directives).

Attention is drawn to the possibility that some of the elements of this document may be the subject of patent rights. ISO shall not be held responsible for identifying any or all such patent rights. Details of any patent rights identified during the development of the document will be in the Introduction and/or on the ISO list of patent declarations received (see www.iso.org/patents).

Any trade name used in this document is information given for the convenience of users and does not constitute an endorsement.

For an explanation on the meaning of ISO specific terms and expressions related to conformity assessment, as well as information about ISO's adherence to the WTO principles in the Technical Barriers to Trade (TBT) see the following URL: [Foreword - Supplementary information](#)

The committee responsible for this document is ISO/TC 38, *Textiles*, Subcommittee SC 23, *Fibres and yarns*.

ISO 17608:2015

<https://standards.iteh.ai/catalog/standards/sist/ccc4ad22-68ff-45fd-b5b5-abca63eafc82/iso-17608-2015>

Textiles — Bare elastane yarns — Determination of resistance to chlorinated water (swimming-pool water)

1 Scope

This International Standard specifies a method to determine the resistance of bare elastane yarns to chlorinated aqueous environments, such as swimming pools, through testing of the breaking force retention.

Different alternative test conditions are specified. Three different concentrations and two different exposure hours are considered.

This International Standard is applicable to bare elastane yarns only. Result achieved from yarns cannot be used to predict the fabric performance.

2 Normative references

The following documents, in whole or in part, are normatively referenced in this document and are indispensable for its application. For dated references, only the edition cited applies. For undated references, the latest edition of the referenced document (including any amendments) applies.

ISO 139, *Textiles — Standard atmospheres for conditioning and testing*

ISO 3696, *Water for analytical laboratory use — Specification and test methods*

<https://standards.iteh.ai/catalog/standards/sist/ccc4ad22-68ff-45fd-b5b5-abca63eafc82/iso-17608-2015>

3 Terms and definition

For the purposes of this document, the following terms and definitions apply.

3.1

elastane yarn

fibre composed of at least 85 % by mass of a segmented polyurethane and which, if stretched to three times its unstretched length, rapidly reverts substantially to the unstretched length when the tension is removed

3.2

breaking force retention

capability of a specimen to retain breaking force after a specified treatment whereby the breaking force of the treated specimen is expressed as a percentage of the initial breaking force

4 Principle

Bare elastane yarn is subjected to a “chlorinated-water exposure test”. The physical properties are affected by active chlorine in the solution.

The breaking force retention is the parameter used to determine the chlorine-resistant performance.

5 Apparatus

5.1 Suitable mechanical device, consisting of a water bath containing a rotatable shaft which supports, radially, stainless steel containers of a diameter of (75 ± 5) mm and a height of (125 ± 10) mm in (550 ± 50) ml capacity, with covers to be sealed.

The bottom of each container is (45 ± 10) mm from the centre of the shaft. The shaft/container assembly is rotated at a frequency of (40 ± 2) r/min.

The temperature of the water bath is thermostatically controlled to maintain the prescribed temperature ± 2 °C.

Other mechanical devices may be used for the test provided that equivalent results are obtained.

5.2 CRE (constant-rate-of-extension) machine, which meets the following requirements.

- a) The gauge length is set to be $(50 \pm 0,5)$ mm and constant rates of extension to be (500 ± 10) mm per min.
- b) The error of the indicated or recorded maximum force, at any point in the range in which the machine is used, shall not exceed 1 %.

The error of the indicated or recorded jaw separation shall not exceed 0,5 mm.

- c) The jaws shall be capable of holding the test specimen without allowing it to slip.

It is designed so that the jaws do not cut or otherwise weaken the test specimen.

- d) The machine shall be provided with the means for indicating or recording the force within gauge length.
- e) The machine is capable of applying a pre-tension as prescribed by the method.

5.3 Winding frame, designed to wind elastane yarn with pre-tension (see [Figure 1](#)).

Dimensions in millimetres

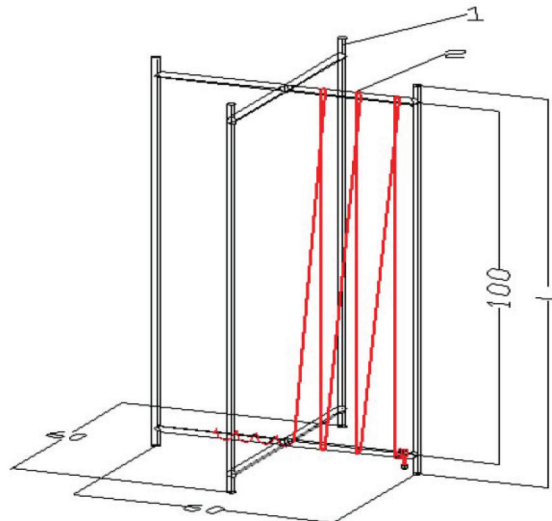

Figure 1 — Winding frame

Key

- 1 winding frame
- 2 specimen
- L* height of the frame, subjected to height of the containers (5.1), as to avoid shaking while rotated

5.4 pH-meter, having an accuracy of 0,02 units.

6 Reagents

6.1 Deionized water, Grade 3 quality as specified in ISO 3696.

6.2 Use only reagents of recognized analytical grade.

6.3 Sodium hypochlorite, (NaClO), **aqueous solution**, having the following composition:

- Active chlorine: 40 g/l to 160 g/l.
- Sodium chloride (NaCl): 120 g/l to 170 g/l.
- Sodium hydroxide (NaOH): 20 g/l maximum.
- Sodium carbonate (Na₂CO₃): 20 g/l maximum.
- Iron (Fe): 0,01 g/l maximum.

6.4 Potassium dihydrogenphosphate (KH₂PO₄).

6.5 Disodium hydrogenphosphate dihydrate (Na₂HPO₄·2H₂O), or **disodium hydrogenphosphate dodecahydrate** (Na₂HPO₄·12H₂O).

6.6 Sodium hypochlorite, (NaClO), **aqueous solution**, containing 100 mg of active chlorine per litre, at pH = 7,50 ± 0,05.

Prepare solutions as follows, using deionized water (6.1).

- Solution 1: dilute 20,0 ml sodium hypochlorite solution (6.3) to 1 l.
- Solution 2: 14,35 g KH₂PO₄ (6.4) per litre.
- Solution 3: 20,05 g Na₂HPO₄·2H₂O (6.5) per litre, or 40,35 g Na₂HPO₄·12H₂O (6.5) per litre.

To 25,0 ml of Solution 1, add excess of potassium iodide (KI) and hydrochloric acid (HCl), and titrate the liberated iodine with a sodium thiosulfate solution, $c(\text{Na}_2\text{S}_2\text{O}_3) = 0,1 \text{ mol/l}$, using starch solution as indicator.

Let the volume of sodium thiosulfate solution required be V ml.

For each litre of working solution at pH 7,50 ± 0,05, use:

- 705,0/ V ml of Solution 1;
- 100,0 ml of Solution 2;
- 500,0 ml of Solution 3.

Dilute to 1 l, with water.

Before use, check the pH of the solution with a pH-meter (5.4).

ISO 17608:2015(E)

If necessary, adjust the pH using either sodium hydroxide, $c(\text{NaOH}) = 0,1 \text{ mol/l}$, or acetic acid, $c(\text{CH}_3\text{COOH}) = 0,1 \text{ mol/l}$.

All sodium hypochlorite solutions should be prepared just prior to use.

6.7 Sodium hypochlorite, (NaClO), aqueous solution, containing 50 mg of active chlorine per litre, at $\text{pH} = 7,50 \pm 0,05$.

Follow the same procedure as in 6.6, except that, for each litre of working solution at $\text{pH} 7,50 \pm 0,05$, use:

705,0/2V ml of Solution 1.

All sodium hypochlorite solutions should be prepared just prior to use.

6.8 Sodium hypochlorite, (NaClO), aqueous solution, containing 20 mg of active chlorine per litre, at $\text{pH} = 7,50 \pm 0,05$.

Follow the same procedure as in 6.6, except that, for each litre of working solution at $\text{pH} 7,50 \pm 0,05$, use:

705,0/5V ml of Solution 1.

All sodium hypochlorite solutions should be prepared just prior to use.

7 Conditioning and testing atmosphere

The standard atmosphere for conditioning and testing shall comply with ISO 139.

8 Preparing test specimens

ISO 17608:2015

<https://standards.iteh.ai/catalog/standards/sist/ccc4ad22-68ff-45fd-b5b5->

8.1 Prepare 2 samples for each package and number from 1 to 2 in sequence.

Specimens from number 1 will be tested breaking force 'before exposure', while those from number 2 will be tested 'after exposure'.

8.2 Discard yarn on the outer layer of a package (about 1 g) and cut yarn to a length of 1,5 m as the first sample.

Discard more yarn, about 3 m to 5 m, before cutting the next sample from the same package.

Carefully unwind the yarn using the smallest amount of tension as possible, so as to prevent any over-tensioning.

9 Testing procedure

9.1 Fix one end of the yarn on the cross part of the winding frame, to avoid any slipping. Wind sample number 2 (8.1) on the frame (see Figure 1), with the pre-tension related to nominal linear density as recommended in Table 1. Tie another end of the yarn on the frame and ensure that it does not slip. Try to prevent the parts from touching each other.

Table 1 — Pre-tension options list

Nominal linear density	Pre-tension
≤ 25 dtex	0,020 cN ± 0,000 2 cN
> 25 dtex to approximately 35 dtex	0,030 cN ± 0,000 3 cN
> 35 dtex to approximately 50 dtex	0,040 cN ± 0,000 4 cN
> 50 dtex to approximately 90 dtex	0,070 cN ± 0,000 7 cN
> 90 dtex to approximately 120 dtex	0,105 cN ± 0,001 0 cN
> 120 dtex to approximately 160 dtex	0,140 cN ± 0,001 4 cN
> 160 dtex to approximately 250 dtex	0,210 cN ± 0,002 1 cN
> 250 dtex to approximately 350 dtex	0,300 cN ± 0,003 0 cN
> 350 dtex	Calculated as (0,001 0 ± 0,000 01) cN/dtex

9.2 Treat each sample in a separate container in the mechanical device (5.1). Immerse the frame with the sample into the sodium hypochlorite solution (6.6, 6.7, or 6.8), ensuring that the solution filled the container and the sample is thoroughly wetted. Close and agitate the container at (27 ± 2) °C for 24 h or 72 h.

9.3 Remove the frame with the sample from the container. Rinse with deionized water (6.1) three times and air-dry at room temperature for at least 15 min.

9.4 Cut sample number 1 (8.1) into several smaller parts in length of 10 cm with a minimum of 5 parts from each sample. Hereafter, these smaller parts are referred to as “specimens”.

Repeat the same procedure to cut sample number 2, which were “after exposure” (see 9.3), discarding those parts bent around frames.

In all, there are a minimum of 5 specimens from the same sample (8.1).

9.5 Condition the specimens in a standard atmosphere (see Clause 7), in a tension-free state for over 2 h.

9.6 Choose an appropriate measurement range on the CRE machine (5.2), such that the indicated or recorded maximum breaking force is between 10 % to 90 % of the full range.

9.7 Place one end of the specimen in the middle of the upper-clamp and the other end in the middle of the lower-clamp, at a pre-tension specified in 9.1.

Ensure the specimen lies along the axis of CRE machine and tighten the clamps.

Set the traversing clamp in motion and extend the specimen to rupture, recording the breaking force.

9.8 If the specimen has slipped or broken near the jaw, discard it and replace it with another one.

9.9 Repeat procedure 9.7 and test 5 specimens cut from same numbered sample.

9.10 Test 5 specimens from number 1.

Calculate the mean value of the 5 individual breaking forces. Report this mean value as the breaking force “before exposure” (F_1).

9.11 Test 5 specimens from number 2.

Calculate the mean value of the 5 individual breaking forces. Report this mean value as the breaking force “after exposure” (F_2).