



Designation: F2236–03 Designation: F 2236 – 08

Standard Consumer Safety Specification for Soft Infant Carriers¹

This standard is issued under the fixed designation F 2236; the number immediately following the designation indicates the year of original adoption or, in the case of revision, the year of last revision. A number in parentheses indicates the year of last reapproval. A superscript epsilon (ϵ) indicates an editorial change since the last revision or reapproval.

INTRODUCTION

This consumer safety specification is intended to address incidents reported by the U.S. Consumer Product Safety Commission (CPSC) relating to soft infant carriers.

In response to the incident data compiled by the CPSC, this consumer safety specification attempts to minimize the hazards associated with these products from the following: (1) occupant retention, (2) structural integrity, (3) deficiency of consumer education regarding product use. This consumer safety specification is intended to deal with reasonably foreseeable use and misuse of the products. This consumer safety specification does not apply to products that are blatantly misused, nor does it apply to products used by consumers in a careless manner that violate normal practice or disregard the instructions or warnings provided with the product, or both.

1. Scope

1.1 This consumer safety specification establishes performance requirements, test methods and marking requirements to promote safe use of soft infant carriers.

1.2 This consumer safety specification is intended to minimize the risk of incidents to an infant from the normal use and reasonably foreseeable misuse of these products.

1.3 For purposes of definition, a soft infant carrier is a product, normally of sewn fabric construction, which is designed to contain a full term infant, generally in an upright position, in close proximity to the caregiver. In general, the child will weigh between 7 and 25 lb (3.2 and 11.3 kg). The soft infant carrier is normally “worn” by the caregiver with the carrier, and thus the infant, suspended from one or both shoulders of the caregiver. These products are generally worn on the front of the caregiver’s body with the infant either facing towards or away from the caregiver. This consumer safety specification does not include products generally referred to as “slings.”

1.4 No soft infant carrier produced after the approval date of this consumer safety specification shall, either by label or other means, indicate compliance with the specification unless it complies with all of the requirements contained herein.

1.5 This consumer safety specification is not intended to address incidents and injuries resulting from the interaction of other persons or objects with the caregiver and infant while the soft carrier is in use.

1.6 The test values stated in inch-pound units in this consumer safety specification are to be regarded as the standard. The metric values in parentheses are for reference only.

1.7 The following precautionary caveat pertains only to the test method portion, Section 7 of this consumer safety specification. *This standard does not purport to address all of the safety concerns, if any, associated with its use. It is the responsibility of the user of this standard to establish appropriate safety and health practices and determine the applicability of regulatory requirements prior to use.*

2. Referenced Documents

2.1 ASTM Standards:²

D 3359 Test Methods for Measuring Adhesion by Tape Test

F 977 Consumer Safety Specification for Infant Walkers

2.2 Federal Regulations:³

16CFR 1303 Ban of Lead-Containing Paint and Certain Consumer Products Bearing Lead-Containing Paint

¹ This consumer safety specification is under the jurisdiction of ASTM Committee F15 on Consumer Products and is the direct responsibility of Subcommittee F15.21 on Hand-Held Infant Carriers, Bouncers, Bouncers and Baby Swings.

Current edition approved March 10, 2003; 1, 2008. Published April 2008. Originally approved in 2003. Last previous edition approved in 2003 as F 2236 – 03.

² For referenced ASTM standards, visit the ASTM website, www.astm.org, or contact ASTM Customer Service at service@astm.org. For Annual Book of ASTM Standards volume information, refer to the standard’s Document Summary page on the ASTM website.

³ Code of Federal Regulations, available from U.S. Government Printing Office, Washington, DC 20402.

16CFR 1500 Hazardous Substance Act Regulations

16CFR 1500.48 Technical Requirements for Determining a Sharp Point in Toys or Other Articles Intended for Use By Children Under Eight Years of Age

16CFR 1500.49 Technical Requirements for Determining a Sharp Metal or Glass Edge in Toys or Other Articles Intended for Use By Children Under Eight Years of Age

16CFR 1500.50-.51 Test Methods for Simulating Use and Abuse of Toys and Other Articles for Use by Children

16CFR 1501 Method for Identifying Toys and Other Articles Intended for Use by Children Under Three Years of Age Which Present Choking, Aspiration or Ingestion Hazards Because of Small Parts

3. Terminology

3.1 Definitions:

3.1.1 *conspicuous*—~~a label~~—label which is visible when the product is in the manufacturer's use position to a caregiver who is placing the occupant in the soft carrier or when the caregiver places the product on his or her body.

3.1.2 *cord*—length of slender, flexible material including monofilaments, rope, woven and twisted cord, plastic or textile tapes, ribbons and those fibrous materials commonly called string.

3.1.3 *dynamic load*—application of impulsive force through free fall of a weight.

3.1.4 *fabric*—any woven, knit, coated, laminated, extruded or calendared flexible material that is intended to be sewn, welded, heat sealed, or glued together as an assembly.

3.1.5 *leg opening*—~~the opening~~—opening in the soft carrier through which the occupant's legs extend when the product is used in the manufacturer's recommended use position.

3.1.6 *manufacturer's recommended use position(s)*— any position that is presented as a normal, allowable, or acceptable configuration for use of the product by the manufacturer in any descriptive or instructional literature. This specifically excludes positions that the manufacturer shows in a like manner in its literature to be unacceptable, unsafe or not recommended.

3.1.7 *non-paper label*—any label material (such as plastic or metal) that either will not tear without the aid of tools or tears, leaving a sharply defined edge.

3.1.8 *occupant*—that individual who is placed or carried in the soft carrier product in one of the manufacturer's recommended use positions.

3.1.9 *paper label*—any label material which tears without the aid of tools and leaves a fibrous edge.

3.1.10 *seam*—~~a means~~—means of joining fabric components, such as sewing, welding, heat sealing, or gluing.

3.1.11 *static load*—~~a vertically downward force applied by a calibrated force gage or by dead weights.~~—vertically downward force applied by a calibrated force gage or by dead weights.

3.1.12 *unbounded leg opening*—leg opening created by placing the soft carrier on a caregiver's torso and which has an opening circumference composed solely of carrier materials and the caregiver's torso.

4. Calibration and Standardization

4.1 The product shall be completely assembled in accordance with the manufacturer's instructions.

4.2 No testing shall be conducted within 48 h of manufacture.

4.3 The product to be tested shall be at an ambient temperature of $73 \pm 9^\circ\text{F}$ ($23 \pm 5^\circ\text{C}$) for at least one hour before testing. All testing shall be conducted in this temperature range.

4.4 All testing required by this consumer safety specification shall be conducted on the same unit in the order presented in this specification.

5. General Requirements

5.1 *Hazardous Sharp Points or Edges*— There shall be no sharp points or edges as defined by 16CFR 1500.48 and 16CFR 1500.49 before and after testing.

5.2 *Small Parts*—There shall be no small parts as defined by 16CFR 1501 before testing or liberated as a result of testing to this specification.

5.3 *Lead in Paint*—The paint or surface coating on the product shall comply with 16CFR 1303.

5.4 *Wood Parts*—Prior to testing, any wooden parts shall be smooth and free of splinters.

5.5 *Locking and Latching*—Any product designed with a locking and latching device must remain in the manufacturer's recommended use position before and after completion of all tests in this standard.

5.6 *Labeling*—Warning labels (whether paper or non paper) shall be permanent when tested per 7.4-7.6.

5.6.1 Warning statements applied directly onto the surface of the product by hot stamping, heat transfer, printing, wood burning, and so forth shall be permanent when tested in accordance with 7.5.

5.6.2 Non-paper labels shall not liberate small parts when tested in accordance with 7.6.

6. Performance Requirements

6.1 *Leg Openings*—Leg openings shall not permit the passage of the Leg Opening Test Sphere when tested in accordance with 7.1.

6.2 *Dynamic Load*—The carrier shall not create a hazardous condition such as, fasteners breaking or disengaging, or seams separating when tested in accordance with 7.2. Adjustable elements in support/shoulder straps shall not slip more than 1 in. (25 mm) per strap as a result of the dynamic testing in accordance with 7.2.

6.3 *Static Load*—The carrier shall not create a hazardous condition such as: not supporting the test weight, fasteners breaking or disengaging, or seams separating when tested in accordance with 7.3. Adjustable elements in support/shoulder straps shall not slip per strap as per 6.2.

6.4 *Unbounded Leg Opening*—Leg opening shall not allow complete passage of the truncated test cone (see Fig. 1) when tested according to 7.7.

7. Test Methods

7.1 *Leg Openings:*

7.1.1 Fasten the soft carrier to a rigid fixture in a manner such that the leg opening of the carrier is horizontal. The opening shall be as close to the center of the fixture as possible. If the leg opening is adjustable in size to allow for growth, it shall be tested with the leg opening adjusted to its smallest size as described in the manufacturer’s literature or instructions.

~~7.1.2 Place the Leg Opening Test Sphere (see Fig. 1~~

7.1.2 Place the leg opening test sphere (see Fig. 2) inside the carrier and gradually allow the sphere to rest in the leg opening over a period of 5 s. Allow the sphere to rest in the opening for an additional 1 min.

7.1.3 Repeat the test for the other leg opening.

7.2 *Dynamic Load Test:*

7.2.1 Fasten the soft carrier to a ~~Test Torso~~ test torso⁴ (see Fig. 2) ~~Fig. 3~~) as directed in the instruction manual supplied with the product.

7.2.2 Position a weight of 25 lb (11.3 kg) using a 6 to 8 in. diameter shot bag a distance of 1 in. (25 mm) above the seat of the soft carrier. Drop the weight onto the seat ten times with a cycle time of 4 ± 1 s/cycle to preset the adjustment straps. By some appropriate means, mark the position of the adjustment hardware. This will be the start point of the remainder of the test. Drop the weight onto the seat an additional 990 times with a cycle time of 4 ± 1 s/cycle. If the product moves on the test fixture, adjust the fixture or product to maintain the 1 in. (25 mm) drop height.

7.3 *Static Load Test:*

7.3.1 Fasten the soft carrier to a test torso (see Fig. 2) ~~as directed in the instruction manual supplied with the product.~~

~~7.3.2 Using a 6 in. (150 mm) Standard Weld Cap (see Fig. 3) as directed in the instruction manual supplied with the product.~~

7.3.2 Using a 6-in. (150-mm) standard weld cap (see Fig. 4), center a 75 lb. (34.0 kg) weight in the seat area of the soft carrier. Include the weight of the weld cap in the 75 lb (34.0 kg) weight. Gradually apply the weight within a 5 s period and maintain for an additional 1 min.

7.4 *Permanency of Labels and Warnings :*

7.4.1 A paper label (excluding labels attached by a seam) shall be considered permanent if during an attempt to remove it without the aid of tools or solvents, it cannot be removed, it tears into pieces upon removal or such action damages the surface to which it is attached.

⁴A suitable Test Torso is manufactured by Century Sporting Goods (called “Body Opponent Bag”) and is available from various distributors on websites such as: www.superfoots.com/cenbodopbagb, www.karate-mart.com, and karatedepot.com.

⁴ The sole source of supply of the test torso (called “Body Opponent Bag”) known to the committee at this time is Century Sporting Goods. It is available from various distributors on websites such as www.superfoots.com/cenbodopbagb, www.karate-mart.com, and karatedepot.com. If you are aware of alternative suppliers, please provide this information to ASTM International Headquarters. Your comments will receive careful consideration at a meeting of the responsible technical committee, which you may attend.

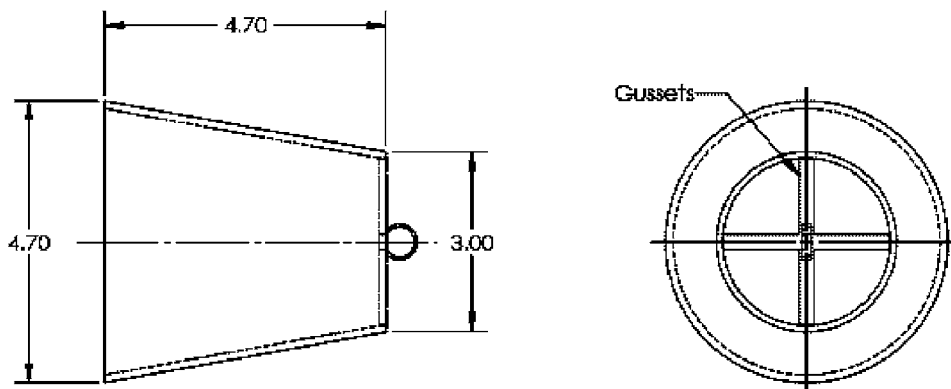

FIG. 1 Truncated Test Cone