**Cutting tool data representation and
exchange —**

**Part 303:
Creation and exchange of 3D models
— Solid end mills**

iTeh STANDARD PREVIEW
*Représentation et échange des données relatives aux outils coupants —
Partie 303: Création et échange de modèles 3D — Fraises cylindriques
deux tailles monobloc*
(standards.iteh.ai)

ISO/TS 13399-303:2016

<https://standards.iteh.ai/catalog/standards/sist/2144cbdc-dd5a-40cb-88ec-36273ba3ad54/iso-ts-13399-303-2016>



iTeh STANDARD PREVIEW
(standards.iteh.ai)

[ISO/TS 13399-303:2016](https://standards.iteh.ai/catalog/standards/sist/2144cbdc-dd5a-40cb-88ec-36273ba3ad54/iso-ts-13399-303-2016)

<https://standards.iteh.ai/catalog/standards/sist/2144cbdc-dd5a-40cb-88ec-36273ba3ad54/iso-ts-13399-303-2016>



COPYRIGHT PROTECTED DOCUMENT

© ISO 2016, Published in Switzerland

All rights reserved. Unless otherwise specified, no part of this publication may be reproduced or utilized otherwise in any form or by any means, electronic or mechanical, including photocopying, or posting on the internet or an intranet, without prior written permission. Permission can be requested from either ISO at the address below or ISO's member body in the country of the requester.

ISO copyright office
Ch. de Blandonnet 8 • CP 401
CH-1214 Vernier, Geneva, Switzerland
Tel. +41 22 749 01 11
Fax +41 22 749 09 47
copyright@iso.org
www.iso.org

Contents

	Page
Foreword	v
Introduction	vii
1 Scope	1
2 Normative references	1
3 Starting elements, coordinate systems, planes	2
3.1 General.....	2
3.2 Reference system.....	2
3.3 Coordinate system at the cutting part.....	3
3.4 Planes.....	3
3.5 Cutting reference point (CRP).....	4
4 Design of the model	5
4.1 General.....	5
4.2 Necessary parameters for the connection interface feature.....	5
5 Non-centre cutting end mill	5
5.1 General.....	5
5.2 Necessary properties.....	6
5.3 Geometry of the non-cutting part inclusive of the connection.....	7
5.4 Geometry of the cutting part.....	7
5.5 Complete non-centre cutting end mill.....	8
6 Centre cutting end mill	9
6.1 General.....	9
6.2 Necessary properties.....	9
6.3 Geometry of the non-cutting part inclusive of the connection.....	9
6.4 Geometry of the cutting part.....	10
6.5 Complete centre cutting end mill.....	10
7 Angular end mill (V-groove)	11
7.1 General.....	11
7.2 Necessary properties.....	11
7.3 Geometry of the non-cutting part inclusive of the connection.....	11
7.4 Geometry of the cutting part.....	12
7.5 V-groove end mill, complete.....	13
8 Dovetail end mill	13
8.1 General.....	13
8.2 Necessary properties.....	13
8.3 Geometry of the non-cutting part inclusive of the connection.....	13
8.4 Geometry of the cutting part.....	14
8.5 Complete dovetail end mill, complete.....	15
9 T-slot end mill	15
9.1 General.....	15
9.2 Necessary properties.....	15
9.3 Geometry of the non-cutting part inclusive of the connection.....	15
9.4 Geometry of the cutting part.....	16
9.5 Complete T-slot end mill.....	16
10 Ball-nosed end mill	17
10.1 General.....	17
10.2 Necessary properties.....	17
10.3 Geometry of the non-cutting part inclusive of the connection.....	18
10.4 Geometry of the cutting part.....	18
10.5 Complete ball-nosed end mill.....	18
11 Die end mill	19

11.1	General.....	19
11.2	Necessary properties.....	19
11.3	Geometry of the non-cutting part inclusive of the connection.....	20
11.4	Geometry of the cutting part.....	20
11.5	Complete die end mill.....	20
12	Concave rounded profile end mill.....	21
12.1	General.....	21
12.2	Necessary properties.....	21
12.3	Geometry of the non-cutting part inclusive of the connection.....	21
12.4	Geometry of the cutting part.....	21
12.5	Complete concave rounded profile end mill.....	22
13	Thread end mill.....	23
13.1	General.....	23
13.2	Necessary properties.....	23
13.3	Geometry of the non-cutting part inclusive of the connection.....	24
13.4	Geometry of the cutting part.....	24
13.5	Complete thread end mill.....	24
14	Cutting stylus.....	25
14.1	General.....	25
14.2	Necessary properties.....	25
14.3	Geometry of the non-cutting part inclusive of the connection.....	26
14.4	Geometry of the cutting part.....	26
14.5	Complete cutting stylus, complete.....	26
15	Thread end mill with drilling part.....	27
15.1	General.....	27
15.2	Necessary properties.....	27
15.3	Geometry of the non-cutting part inclusive of the connection.....	28
15.4	Geometry of the cutting part.....	28
15.5	Complete thread end mill with drilling part.....	28
16	Design of details.....	29
16.1	Basics for modelling.....	29
16.2	Contact/clamping surfaces — Orientation.....	29
16.3	Chamfers, rounding, others.....	29
17	Attributes of surfaces — Visualization of the model features.....	29
18	Structure of the design elements (tree of model).....	30
19	Data exchange model.....	30
Annex A (informative) Information about nominal dimensions.....		32
Bibliography.....		33

ITeH STANDARD PREVIEW
 (standards.iteh.ai)
 ISO/TS 13399-303:2016
<https://standards.iteh.ai/catalog/standards/sist/2144cbdc-dd5a-40cb-88ec-36275ba5ad54/iso-ts-13399-303-2016>

Foreword

ISO (the International Organization for Standardization) is a worldwide federation of national standards bodies (ISO member bodies). The work of preparing International Standards is normally carried out through ISO technical committees. Each member body interested in a subject for which a technical committee has been established has the right to be represented on that committee. International organizations, governmental and non-governmental, in liaison with ISO, also take part in the work. ISO collaborates closely with the International Electrotechnical Commission (IEC) on all matters of electrotechnical standardization.

The procedures used to develop this document and those intended for its further maintenance are described in the ISO/IEC Directives, Part 1. In particular the different approval criteria needed for the different types of ISO documents should be noted. This document was drafted in accordance with the editorial rules of the ISO/IEC Directives, Part 2 (see www.iso.org/directives).

Attention is drawn to the possibility that some of the elements of this document may be the subject of patent rights. ISO shall not be held responsible for identifying any or all such patent rights. Details of any patent rights identified during the development of the document will be in the Introduction and/or on the ISO list of patent declarations received (see www.iso.org/patents).

Any trade name used in this document is information given for the convenience of users and does not constitute an endorsement.

For an explanation on the meaning of ISO specific terms and expressions related to conformity assessment, as well as information about ISO's adherence to the WTO principles in the Technical Barriers to Trade (TBT) see the following URL: [Foreword - Supplementary information](#)

The committee responsible for this document is ISO/TC 29, *Small tools*.

ISO/TS 13399 consists of the following parts, under the general title *Cutting tool data representation and exchange*: <https://standards.iteh.ai/catalog/standards/sist/2144cbdc-dd5a-40cb-88ec-36273ba3ad54/iso-ts-13399-303-2016>

- *Part 1: Overview, fundamental principles and general information model*
- *Part 2: Reference dictionary for the cutting items* [Technical Specification]
- *Part 3: Reference dictionary for tool items* [Technical Specification]
- *Part 4: Reference dictionary for adaptive items* [Technical Specification]
- *Part 5: Reference dictionary for assembly items* [Technical Specification]
- *Part 50: Reference dictionary for reference systems and common concepts* [Technical Specification]
- *Part 60: Reference dictionary for connection systems* [Technical Specification]
- *Part 80: Creation and exchange of 3D models — Overview and principles* [Technical Specification]
- *Part 100: Definitions, principles and methods for reference dictionaries* [Technical Specification]
- *Part 150: Usage guidelines* [Technical Specification]
- *Part 201: Creation and exchange of 3D models — Regular inserts* [Technical Specification]
- *Part 202: Creation and exchange of 3D models — Irregular inserts* [Technical Specification]
- *Part 203: Creation and exchange of 3D models — Replaceable inserts for drilling* [Technical Specification]
- *Part 204: Creation and exchange of 3D models — Inserts for reaming* [Technical Specification]
- *Part 301: Concept for the design of 3D models based on properties according to ISO/TS 13399-3: Modelling of thread-cutting taps, thread-forming taps and thread-cutting dies* [Technical Specification]

ISO/TS 13399-303:2016(E)

- *Part 302: Concept for the design of 3D models based on properties according to ISO/TS 13399-3: Modelling of solid drills and countersinking tools* [Technical Specification]
- *Part 303: Concept for the design of 3D models based on properties according to ISO/TS 13399-3: Modelling of end mills with solid cutting edges* [Technical Specification]
- *Part 304: Concept for the design of 3D models based on properties according to ISO/TS 13399-3: Modelling of milling cutters with arbor hole and solid cutting edges* [Technical Specification]
- *Part 307: Creation and exchange of 3D models — End mills for indexable inserts* [Technical Specification]
- *Part 308: Creation and exchange of 3D models — Milling cutters with arbor hole for indexable inserts* [Technical Specification]
- *Part 309: Creation and exchange of 3D models — Tool holders for indexable inserts* [Technical Specification]
- *Part 311: Creation and exchange of 3D models — Solid reamers* [Technical Specification]
- *Part 312: Creation and exchange of 3D models — Reamers for indexable inserts* [Technical Specification]
- *Part 401: Creation and exchange of 3D models — Converting, extending and reducing adaptive items* [Technical Specification]
- *Part 405: Creation and exchange of 3D models — Collets* [Technical Specification]

The following parts are under preparation:

- *Part 70: Graphical data layout — Layer settings for tool designs* [Technical Specification]
- *Part 71: Graphical data layout — Creation of documents for the standardized data exchange — Graphical product information* [Technical Specification]
- *Part 72: Creation of documents for the standardized data exchange — Definition of properties for drawing header and their XML-data exchange* [Technical Specification]
- *Part 305: Creation and exchange of 3D models — Modular tooling systems with adjustable cartridges for boring* [Technical Specification]
- *Part 310: Creation and exchange of 3D models — Turning tools with carbide tips* [Technical Specification]

Introduction

This part of ISO/TS 13399 defines the concept, the terms and the definitions on how to design simplified 3D models of milling cutters with arbors hole for indexable inserts that can be used for NC-programming, simulation of the manufacturing processes and the determination of collision within machining processes. It is not intended to standardize the design of the cutting tool itself.

A cutting tool is used in a machine to remove material from a workpiece by a shearing action at the cutting edges of the tool. Cutting tool data that can be described by ISO/TS 13399 (all parts) include, but are not limited to, everything between the workpiece and the machine tool. Information about inserts, solid tools, assembled tools, adaptors, components and their relationships can be represented by ISO/TS 13399 (all parts). The increasing demand providing the enduser with 3D models for the purposes defined above is the basis for the development of this series of International Standards.

The objective of this International Standard is to provide the means to represent the information that describes cutting tools in a computer sensible form that is independent from any particular computer system. The representation will facilitate the processing and exchange of cutting tool data within and between different software systems and computer platforms and support the application of this data in manufacturing planning, cutting operations and the supply of tools. The nature of this description makes it suitable not only for neutral file exchange, but also as a basis for implementing and sharing product databases and for archiving. The methods that are used for these representations are those developed by ISO/TC 184/SC 4 for the representation of product data by using standardized information models and reference dictionaries.

Definitions and identifications of dictionary entries are defined by means of standard data that consist of instances of the EXPRESS entity data types defined in the common dictionary schema, resulting from a joint effort between ISO/TC 184/SC 4 and IEC/TC 3/SC 3D, and in its extensions defined in ISO 13584-24 and ISO 13584-25.

[ISO/TS 13399-303:2016](https://standards.iteh.ai/catalog/standards/sist/2144cbdc-dd5a-40cb-88ec-36273ba3ad54/iso-ts-13399-303-2016)

<https://standards.iteh.ai/catalog/standards/sist/2144cbdc-dd5a-40cb-88ec-36273ba3ad54/iso-ts-13399-303-2016>

iTeh STANDARD PREVIEW
(standards.iteh.ai)

[ISO/TS 13399-303:2016](https://standards.iteh.ai/catalog/standards/sist/2144cbdc-dd5a-40cb-88ec-36273ba3ad54/iso-ts-13399-303-2016)

<https://standards.iteh.ai/catalog/standards/sist/2144cbdc-dd5a-40cb-88ec-36273ba3ad54/iso-ts-13399-303-2016>

Cutting tool data representation and exchange —

Part 303:

Creation and exchange of 3D models — Solid end mills

1 Scope

This part of ISO/TS 13399 specifies a concept for the design of tool items, limited to solid (non-indexable) end mills, with the usage of the related properties and domains of values.

This part of ISO/TS 13399 specifies a common way of design simplified models that contain the following:

- definitions and identifications of the design features of solid (non-indexable) end mills, with a link to the properties used;
- definitions and identifications of the internal structure of the 3D model that represents features and properties of solid (non-indexable) end mills.

The following are outside the scope of this part of ISO/TS 13399:

- applications where these standard data may be stored or referenced;
- creation and exchange of simplified 3D models for cutting tools;
- creation and exchange of simplified 3D models for cutting items;
- creation and exchange of simplified 3D models for other tool items not being described in the scope of this part of ISO/TS 13399;
- creation and exchange of simplified 3D models for adaptive items;
- creation and exchange of simplified 3D models for assembly items and auxiliary items.

2 Normative references

The following documents, in whole or in part, are normatively referenced in this document and are indispensable for its application. For dated references, only the edition cited applies. For undated references, the latest edition of the referenced document (including any amendments) applies.

ISO/TS 13399-3, *Cutting tool data representation and exchange — Part 3: Reference dictionary for tool items*

ISO/TS 13399-4, *Cutting tool data representation and exchange — Part 4: Reference dictionary for adaptive items*

ISO/TS 13399-60, *Cutting tool data representation and exchange — Part 60: Reference dictionary for connection systems*

ISO/TS 13399-80, *Cutting tool data representation and exchange — Part 80: Creation and exchange of 3D models — Overview and principles*

3 Starting elements, coordinate systems, planes

3.1 General

The design of the 3D models will be done by means of nominal dimensions.

WARNING — There is no guarantee that the 3D model, created according to the methods described in this part of ISO/TS 13399, is a true representation of the physical tool supplied by the tool manufacturer. If the models are used for simulation purposes, e.g. CAM simulation, it shall be taken into consideration that the real product dimensions can differ from those nominal dimensions.

NOTE Some definitions are taken from ISO/TS 13399-50.

3.2 Reference system

The reference system consists of the following standard elements as shown in [Figure 1](#):

- **standard coordinate system**: right-handed rectangular Cartesian system in three-dimensional space, called “primary coordinate system” (PCS);
- **orthogonal planes**: planes in the coordinate system that contain the axis of the system, named “xy-plane” (XYP), “xz-plane” (XZP) and “yz-plane” (YZP)
- **orthogonal axis**: axes built as intersections of the three orthogonal planes lines respectively, named “x-axis” (XA), “y-axis” (YA) and “z-axis” (ZA)

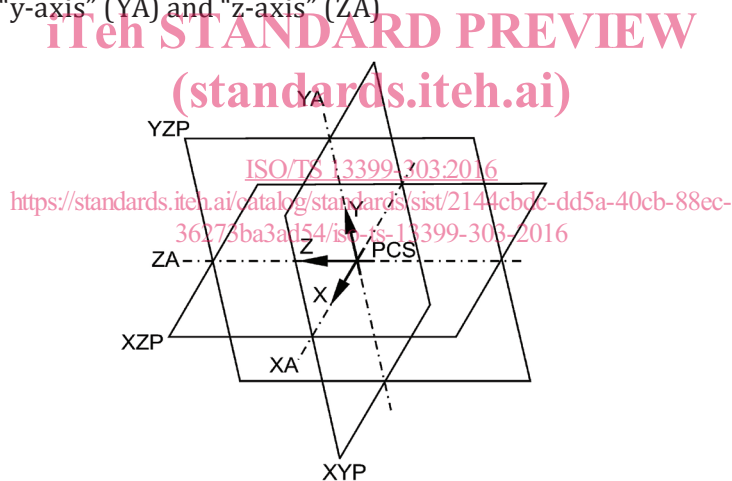

Figure 1 — Reference system

For virtually mounting of solid end mills onto an adaptive item, an additional reference system shall be defined. This reference system is called “mounting coordinate system” (MCS). It is located at the starting point of the protruding length of a tool item. The orientation is shown in [Figure 2](#).

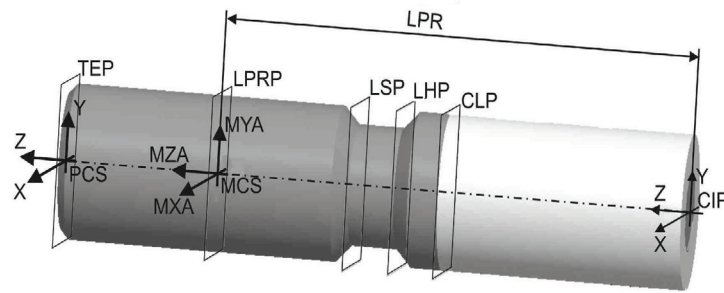

Figure 2 — Orientation of “PCS” and “MCS” reference system (example)

3.3 Coordinate system at the cutting part

The coordinate system at the cutting part, e.g. the centre cutting edge or the planar face, named “coordinate system in process” (CIP), with a defined distance to the PCS, shall be oriented as follows and shown in [Figure 3](#):

- z-axis of CIP points to the PCS;
- z-axis of CIP is collinear to the z-axis of PCS;
- y-axis of CIP is parallel to the y-axis of PCS.



Figure 3 — Orientation of CIP

If the 3D modelling software gives the possibility to include interfaces for components to, for example, mount a face cutting part on to a complete cutting tool, it will be advised to use the coordinate system “CIP”.

If necessary, another designation should be given to the interface of the component (dependent on the software). The name is “CSIF” (for “coordinate system interface”) and includes the coordinate system “CIP”.

3.4 Planes

The modelling shall be based on planes according to [Figure 4](#), which shall be used as reference, if applicable. Therefore, it is ensured that the model can be varied to suppress single features of independent design features by means of changing the value of one or more parameters. Furthermore, the identification of the different features shall be simplified in using the plane concept even if they contact each other with the same size, e.g. chip flute, shank.

For the 3D visualization of solid end mills, the planes shall be determined as follows.

- “LHP” head length plane: plane for the head length (LH); based on “CIP”.
- “LSP” shank length plane: plane for the shank length (LS); based on “PCS”.
- “LPRP” protruding length plane: plane for the protruding length (LPR); based on “CIP”.
- “TEP” tool end plane: the tool end plane is located at that end of the connection that points away from the workpiece. If the tool does not have a contact surface and/or a gauge line, the TEP is coplanar with the XY-plane of the PCS. The overall length (OAL) is the distance between CIP and TEP.
- “CLP” cutting length plane: plane for the cutting depth maximum (APMX); based on “CIP”.

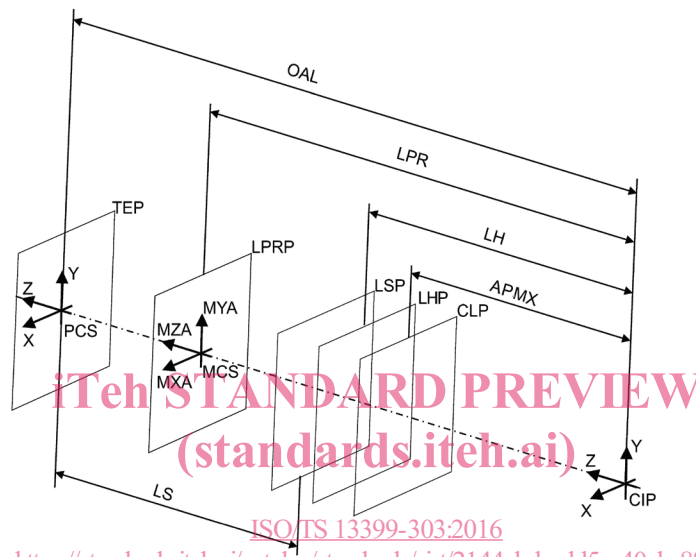

ISO/TS 13399-303:2016
<https://standards.iteh.ai/catalog/standards/sist/2144cbdc-dd5a-40cb-88ec-36273ba3ad54/iso-ts-13399-303-2016>

Figure 4 — Planes for design

3.5 Cutting reference point (CRP)

The cutting reference point is the theoretical point of the cutting tool from which the major functional dimensions are taken. Therefore, it shall always be referenced to the cutting diameter as shown in [Figure 5](#).

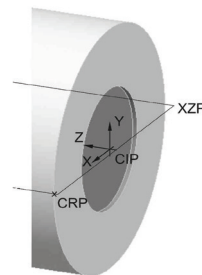

Figure 5 — Position of the cutting reference point “CRP”

4 Design of the model

4.1 General

The sketches (outline contour) and features of the crude geometry may not contain details, like grooves, chamfers, rounding. Those features shall be designed as separate design elements after the crude geometry and shall be grouped as a detailed geometry.

The order of the structure of the model shall be kept by means of the state of the technology of the CAD systems. It shall be waived on references between the design components of the cutting and non-cutting part.

Solid end mills shall be designed as rotational symmetric elements based on properties in accordance with ISO/TS 13399-3.

- Geometry of the non-cutting part, including the connection interface, if applicable;
- Geometry of the cutting part.

Both geometrical parts shall be coloured as described in [Clause 18](#).

The total amount of design elements shall be dependent on the level of detail and on the complexity of the tool item.

The specified model structure of the defined basic shapes of solid end mills shall be described as defined in the next clauses of this part of ISO/TS 13399.

The section of “CUT” area ends at the cutting length plane (CLP).

The examples of the design of the different tool types are shown with a cylindrical round shank representing the connection interface feature.

<https://standards.iteh.ai/catalog/standards/sist/2144cbdc-dd5a-40cb-88ec-36277ba3ad54/iso-ts-13399-303-2016>

4.2 Necessary parameters for the connection interface feature

Information about the connection interface code shall be filed as properties within the model and being named as parameters, as indicated in [Table 1](#).

Table 1 — Property list for connection interface feature

Preferred symbol	Description	Source of symbol	ISO-ID number
CCMS	connection code machine side	ISO/TS 13399-3 and ISO/TS 13399-4	71D102AE3B252
CCTMS	connection code type machine side	ISO/TS 13399-60	726E3E82E53A6
CCFMS	connection code form type machine side	ISO/TS 13399-60	726E3E84DD902
CZCMS	connection size code machine side	ISO/TS 13399-60	727C2BCCC5596

The information above and other relevant properties shall be incorporated into the model as parameters or shall be taken as a separate file.

5 Non-centre cutting end mill

5.1 General

[Figure 6](#) shows the properties used for identification and classification of non-centre cutting end mills.