



SLOVENSKI STANDARD

SIST-TS CEN/TS 16980-1:2017

01-februar-2017

Fotokataliza - Metode preskušanja kontinuiranega pretoka - 1. del: Ugotavljanje razgradnje dušikovega oksida (NO) v zraku z materiali fotokatalize

Photocatalysis - Continuous flow test methods - Part 1: Determination of the degradation of nitric oxide (NO) in the air by photocatalytic materials

Photokatalyse - Durchlaufverfahren - Teil 1: Bestimmung der Verminderung von Stickoxiden (NO) in Luft durch photokatalytische Materialien

Photocatalyse - Méthodes d'essai en flux continu - Partie 1: Détermination de la dégradation du monoxyde d'azote (NO) dans l'air par des matériaux photocatalytiques

<https://standards.iteh.ai/catalog/standards/sist/b832811c-302b-4a34-9faf-be989754fe2e/sist-ts-cen-ts-16980-1-2017>

Ta slovenski standard je istoveten z: **CEN/TS 16980-1:2016**

ICS:

25.220.20 Površinska obdelava Surface treatment

SIST-TS CEN/TS 16980-1:2017 en,fr,de

iTeh STANDARD PREVIEW
(standards.iteh.ai)

[SIST-TS CEN/TS 16980-1:2017](https://standards.iteh.ai/catalog/standards/sist/b832811c-302b-4a34-9faf-be989754fe2e/sist-ts-cen-ts-16980-1-2017)

<https://standards.iteh.ai/catalog/standards/sist/b832811c-302b-4a34-9faf-be989754fe2e/sist-ts-cen-ts-16980-1-2017>

TECHNICAL SPECIFICATION
SPÉCIFICATION TECHNIQUE
TECHNISCHE SPEZIFIKATION

CEN/TS 16980-1

December 2016

ICS 25.220.20

English Version

**Photocatalysis - Continuous flow test methods - Part 1:
Determination of the degradation of nitric oxide (NO) in
the air by photocatalytic materials**

Photocatalyse - Méthodes d'essai en flux continu -
Partie 1 : Détermination de la dégradation du
monoxyde d'azote (NO) dans l'air par des matériaux
photocatalytiques

Photokatalyse - Prüfverfahren mit kontinuierlichem
Durchfluss - Teil 1: Bestimmung des Abbaus von
Stickstoffmonoxid (NO) aus der Luft durch
photokatalytische Werkstoffe

This Technical Specification (CEN/TS) was approved by CEN on 8 August 2016 for provisional application.

The period of validity of this CEN/TS is limited initially to three years. After two years the members of CEN will be requested to submit their comments, particularly on the question whether the CEN/TS can be converted into a European Standard.

CEN members are required to announce the existence of this CEN/TS in the same way as for an EN and to make the CEN/TS available promptly at national level in an appropriate form. It is permissible to keep conflicting national standards in force (in parallel to the CEN/TS) until the final decision about the possible conversion of the CEN/TS into an EN is reached.

CEN members are the national standards bodies of Austria, Belgium, Bulgaria, Croatia, Cyprus, Czech Republic, Denmark, Estonia, Finland, Former Yugoslav Republic of Macedonia, France, Germany, Greece, Hungary, Iceland, Ireland, Italy, Latvia, Lithuania, Luxembourg, Malta, Netherlands, Norway, Poland, Portugal, Romania, Slovakia, Slovenia, Spain, Sweden, Switzerland, Turkey and United Kingdom.



EUROPEAN COMMITTEE FOR STANDARDIZATION
COMITÉ EUROPÉEN DE NORMALISATION
EUROPÄISCHES KOMITEE FÜR NORMUNG

CEN-CENELEC Management Centre: Avenue Marnix 17, B-1000 Brussels

Contents	Page
European foreword.....	3
1 Scope	4
2 Normative references	4
3 Terms, definitions and abbreviations	5
3.1 Terms and definitions	5
3.2 Abbreviations	5
4 Principle	7
5 Interferences	7
6 Apparatus	7
7 Sample preparation	13
7.1 Precaution	13
7.2 Sample characteristics	13
7.3 Conditioning	13
8 Measurement of concentrations	14
8.1 General	14
8.2 Measurement of the initial concentration of nitrogen oxides before entering the photochemical reactor	14
8.3 Conversion without sample	14
8.4 Conversion in the dark and in the presence of sample	15
8.5 Conversion under illumination in the presence of sample	15
9 Calculation of photocatalytic degradation rate	17
9.1 The observed rate of photocatalytic degradation	17
9.2 Intrinsic rate of photocatalytic transformation	18
10 Acceptability ranges of main test parameters	18
11 Test report	19
Annex A (informative) Typical trend of NO, NO₂ and NO_x concentrations during a photocatalytic test	21
Annex B (informative) Example of test for the control of mass transfer conditions	22
Annex C (informative) Typical Ohmic response of the fan	23
Bibliography	24

European foreword

This document (CEN/TS 16980-1:2016) has been prepared by Technical Committee CEN/TC 386 “Photocatalysis”, the secretariat of which is held by AFNOR.

Attention is drawn to the possibility that some of the elements of this document may be the subject of patent rights. CEN shall not be held responsible for identifying any or all such patent rights.

This document is part of the CEN/TS 16980 series that consists of the following parts:

- Part 1: *Determination of the degradation of nitric oxide (NO) in the air by photocatalytic materials*
- Part 2: [To be determined].

According to the CEN/CENELEC Internal Regulations, the national standards organisations of the following countries are bound to announce this Technical Specification: Austria, Belgium, Bulgaria, Croatia, Cyprus, Czech Republic, Denmark, Estonia, Finland, Former Yugoslav Republic of Macedonia, France, Germany, Greece, Hungary, Iceland, Ireland, Italy, Latvia, Lithuania, Luxembourg, Malta, Netherlands, Norway, Poland, Portugal, Romania, Slovakia, Slovenia, Spain, Sweden, Switzerland, Turkey and the United Kingdom

iTeh STANDARD PREVIEW (standards.iteh.ai)

[SIST-TS CEN/TS 16980-1:2017](https://standards.iteh.ai/catalog/standards/sist/b832811c-302b-4a34-9faf-be989754fe2e/sist-ts-cen-ts-16980-1-2017)

<https://standards.iteh.ai/catalog/standards/sist/b832811c-302b-4a34-9faf-be989754fe2e/sist-ts-cen-ts-16980-1-2017>

CEN/TS 16980-1:2016 (E)**1 Scope**

This standard describes a method for assessing the performance of photocatalytic inorganic materials contained in cement mortars and/or limes or ceramic-based matrices, paints or materials deposited as thin films or coatings on a variety of substrates for the photocatalytic abatement of nitric oxide in the gas phase. This method is not suitable for the assessment of samples to be applied with flow perpendicular to the surface or flow permeating the surface itself as polymeric and paper filters, honeycomb structures and suchlike.

The performance for the photocatalytic sample under test is evaluated by measuring the degradation rate of nitric oxide (NO) using the method described herein. The photocatalytic abatement rate is calculated from the observed rate by eliminating the effects of mass transfer. The intrinsic photocatalytic abatement rate is an intrinsic property of the material tested and makes it possible to distinguish the photocatalytic activities of various products with an absolute scale defined with physical and engineering meaning.

For the measurements and calculations described in this standard the concentration of nitrogen oxides (NO_x) is defined as the stoichiometric sum of nitric oxide (NO) and nitrogen dioxide (NO₂).

Safety statement

Persons using this document should be familiar with the normal laboratory practice, if applicable. This document cannot address all of the safety problems, if any, associated with its use. It is the responsibility of the user to establish appropriate safety and health practices and to ensure compliance with any regulatory conditions.

Environmental statement

It is understood that some of the material permitted in this standard may have negative environmental impact. As technological advantages lead to better alternatives for these materials, they will be eliminated from this standard to the extent possible.

At the end of the test, the user of the standard will take care to carry out an appropriate disposal of the wastes, according to local regulation.

2 Normative references

The following documents, in whole or in part, are normatively referenced in this document and are indispensable for its application. For dated references, only the edition cited applies. For undated references, the latest edition of the referenced document (including any amendments) applies.

CEN/TS 16599:2014, *Photocatalysis - Irradiation conditions for testing photocatalytic properties of semiconducting materials and the measurement of these conditions*

EN ISO 9169, *Air quality - Definition and determination of performance characteristics of an automatic measuring system (ISO 9169)*

ISO 7996, *Ambient air — Determination of the mass concentration of nitrogen oxides — Chemiluminescence method*

3 Terms, definitions and abbreviations

3.1 Terms and definitions

For the purposes of this document, the following terms, definitions and abbreviations apply.

3.1.1

concentration of nitrogen oxides

NO_x

stoichiometric sum of nitric oxide (NO) and nitrogen dioxide (NO_2)

Note 1 to entry: For grade 999 nitrogen or air: the purity of the gas should be equal at least to 99,9 %.

3.1.2

photocatalyst

Catalyst able to produce, upon absorption of light, chemical transformations of the reaction partners

Note 1 to entry: The excited state of the photocatalyst repeatedly interacts with the reaction partners forming reaction intermediates and regenerates itself after each cycle of such interactions.

3.1.3

photocatalytic materials

materials in which or on which the photocatalyst is added by coating, impregnation, mixing, etc

3.2 Abbreviations

iTeh STANDARD PREVIEW
(standards.iteh.ai)

CSTR	Continuous Stirred-Tank Reactor
$C_{\text{NO}}^{\text{IN}}$	concentration at reactor inlet
$C_{\text{NO}_2, \text{DARK}}^{\text{OUT}}$	concentration of NO and NO_2 at reactor outlet under stable conditions in the dark (no illumination)
$C_{\text{OUT, light}}^{\text{OUT}}$	concentration at reactor outlet under stable conditions with illumination (lamp on)
$C_{\text{NO}}^{\text{IN}}$	concentration of NO at reactor inlet
$C_{\text{NO}_2}^{\text{IN}}$	concentration of NO_2 at reactor inlet
$C_{\text{NO}}^{\text{OUT, DARK}}$	concentration of NO at reactor outlet under stable conditions in the dark (no illumination) without sample
$C_{\text{NO}_2}^{\text{OUT, DARK}}$	concentration of NO_2 at reactor outlet under stable conditions in the dark (no illumination) without sample
$C_{\text{NO, S}}^{\text{OUT, DARK}}$	concentration of NO at reactor outlet under stable conditions in the dark (no illumination) in presence of sample
$C_{\text{NO}_2, S}^{\text{OUT, DARK}}$	concentration of NO_2 at reactor outlet under stable conditions in the dark (no illumination) in presence of sample
$C_{\text{NO}}^{\text{OUT, LIGHT}}$	concentration of NO at reactor outlet under stable conditions with illumination (lamp on) without sample
$C_{\text{NO, 0}}^{\text{OUT, LIGHT}}$	concentration of NO at reactor outlet under illumination of sample measured at fan speed at nominal voltage V_0

CEN/TS 16980-1:2016 (E)

$C_{\text{NO}_2,0}^{\text{OUT,LIGHT}}$	concentration NO_2 at reactor outlet under illumination of sample measured at fan speed nominal voltage V_0
F	Flow
$F_{v,i}$	fan flow at i^{th} potential
I	irradiance
LED	light emitting diodes
MM	molecular mass
P	pressure in atmosphere
PTFE	Polytetrafluoroethylene
R	ideal gas constant
RH	gas relative humidity at 25 °C inside the reactor
$\eta_{\text{NO}}^{\text{dark}}$	conversion of NO in the dark
$\eta_{\text{NO}_2}^{\text{dark}}$	conversion to NO_2 in the dark
$\eta_{\text{NO,lamp}}^{\text{PHOTO}}$	conversion of NO under illumination without sample
$\eta_{\text{NO},i}^{\text{total}}$	conversion of NO measured with fan speed at i^{th} potential
$\eta_{\text{NO}_2,i}^{\text{total}}$	conversion to NO_2 measured with fan speed at i^{th} potential
$r_{\text{NO},i}^{\text{photo}}$	NO abatement rate at each fan speed ($i = 0..n$)
$r_{\text{NO}_2,i}^{\text{photo}}$	NO_2 photocatalytic production rate at each fan speed ($i = 0..n$)
$r_{\text{NO}_x,i}^{\text{photo}}$	NO_x abatement rate correspond to NO abatement rate minus NO_2 photocatalytic production rate
$r_{\text{NO}}^{\text{photoCAT}}$	NO photocatalytic degradation rate intrinsic to the surface of the material, after removing the mass transfer limitations
$r_{\text{NO}_x}^{\text{photoCAT}}$	NO_x photocatalytic degradation rate intrinsic to the surface of the material, after removing the mass transfer limitations
UV-A	ultraviolet with wavelength (λ) situated between 315 nm and 400 nm (IUPAC)
V_0	fan nominal operating potential (in Volt)
V_{min}	fan minimum operating potential (in Volt) set by the manufacturer
S	Sample
T	temperature in Kelvin
t_{stab}	time to reach the stability of NO concentration
UV	UltraViolet
V_r	Reactor net volume

4 Principle

The method consists in measuring the photocatalytic abatement of nitric oxide (NO) by photocatalytic materials as specified in paragraph 1 using a Continuous Stirred-Tank Reactor (CSTR) with flow tangential to the sample. Information on the theory is reported in the specialized literature (Minero et al. 2013). The residual NO and NO_x concentration at the CSTR outlet is measured by a chemiluminescence analyser (ISO 7996).

The photocatalytic activity test is carried out using chromatographic grade air, also obtained by mixing pure gases, to which NO is added in such an amount as to simulate a high degree of air pollution. The NO concentration is set to $(0,50 \pm 0,05)$ ppmv.

5 Interferences

Any measurement interferences are reported in the technical specifications of the chemiluminescence analyser. As what is measured are all species that can be converted by reduction to NO, NO₂ concentration is here defined as $[NO_2] = [NO_x] - [NO]$. For interferences on chemiluminescence detection, see Winer et al. (1974).

6 Apparatus

The test apparatus shall consist of the following main components.

6.1 Gas mixture preparation system.

The system used for preparing the reaction mixture is shown in Figure 1.

The mass flow controllers, calibrated and traceable, shall ensure a maximum flow consistent with that needed for a correct test execution. To ensure the necessary accuracy, the flow shall not exceed 90 % of the rated full scale. <https://standards.iteh.ai/catalog/standards/sist/b832811c-302b-4a34-9faf-be989754fe2e/sist-ts-cen-ts-16980-1-2017>

As an example, to obtain the gas mixture only gases of chromatographic grade or higher purity shall be used. Instead of dry air cylinders, two separate cylinders of pure N₂ and O₂ can be used at the inlet of mass-flow controllers, adjusted so as to produce a mixture consisting of 20,8 % of O₂ and 79,2 % of N₂. The NO concentration to flow #1 is set to $(0,50 \pm 0,05)$ ppmv.

CEN/TS 16980-1:2016 (E)

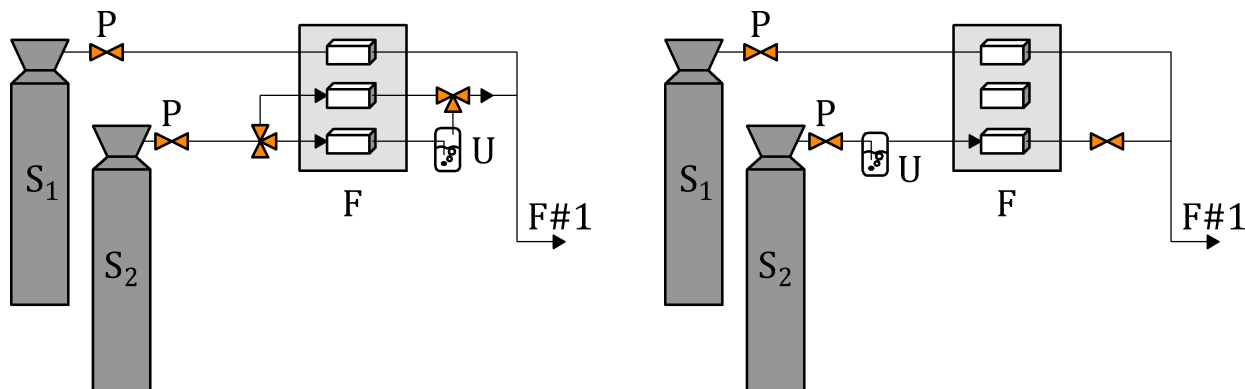

a) Relative humidity is set by regulating the flow to U, which is downstream to F

b) Relative humidity is set by regulating the pressure before U and F

Key

S₁ source of nitric oxide NO diluted in N₂

S₂ cylinder of air (chromatographic grade) or, alternatively, individual cylinders of N₂ and O₂ (chromatographic grade)

F flow controller with mass-flow controllers (2 or 3)

P pressure regulators with low-pressure manometers

U humidifier maintained at controlled temperature

F#1 flow entering the reactor

Figure 1 – Gas mixture preparation system

The humidification of the gas mixture can be obtained with two different configurations:

- using two mass flow controllers regulating the flow to U, as in Figure 1 left;
- using one mass flow controller regulating the pressure on U, as in Figure 1 right.

The gas mixture preparation system shall ensure a relative humidity of $(40 \pm 5) \%$ inside the CSTR reactor. The relative humidity shall be measured either inside the reactor *R* (Figure 2) or immediately at its outlet on flow 2 of Figure 2 by means of a hygro-thermometer.

6.2 Illumination and measuring system:

6.2.1 General:

The light source arrangement and the measuring system are shown in Figure 2.

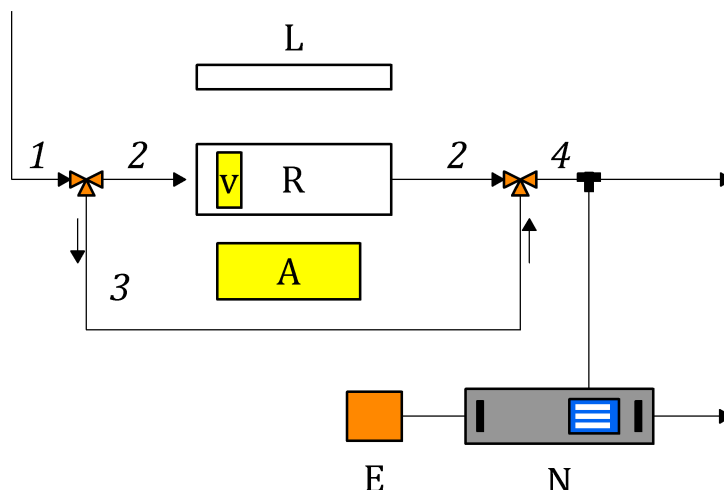
**Key**

- R* reaction chamber, Continuous Stirred-Tank Reactor (CSTR) type
- V* fan
- A* power supply of fan *V*
- N* NO/NO₂ chemiluminescence analyser
- E* processing/logging unit
- L* illumination system
- 1, 2, 3, 4 flow paths, with valves and tubing

Figure 2 — Illumination reaction and measuring system

All parts of the test apparatus, including connections and pipes, which come into contact with the nitric oxide mixture shall be made of chemically inert materials. For pipes and connections PTFE is recommended. The pipes of paths 1, 2, 3, 4 and the related connections shall have an outer diameter of 6 mm (1/4") and inner clearance of at least 4 mm to avoid overpressures that may affect the gas concentration inside the reactor.

Temperature shall be measured and recorded inside the reactor during the test or immediately at its outlet on flow 2 by means of a hygro-thermometer. The gas temperature inside the reaction chamber shall be $(25 \pm 5) ^\circ\text{C}$.

6.2.2 Illumination system *L*:

The illumination source shall consist of any lamp able to excite the photocatalyst (quartz mercury vapor lamps, UV-A fluorescent lamps, Xenon lamps, LEDs, lamps consisting of a metal vapor element combined with tungsten incandescence elements, etc.) as specified in the Technical Specification CEN/TS 16599.

The illumination system shall provide an average irradiance to the test sample surface within the range of wavelengths that are mostly adsorbed by the photocatalyst, equal to $(10,0 \pm 5 \%) \text{ W/m}^2$.

The geometry of the illumination system shall be such that uniform illumination of the sample surface is ensured. The illumination is considered uniform if 5 independent measurements performed on the surface (one in centre position and the other four in positions perpendicular to each other and next to the edge of the sample) show a percentage variation compared to the average value of less than 10%. The control of the uniformity of illumination and average irradiance shall be repeated each time the system geometry changes (position of the lamp or any filters or reflectors, sample position, etc.).

Irradiance shall be measured by placing a radiometric sensor inside the reaction chamber in the same position occupied by the sample in order to measure real irradiance at its surface. A second measuring sensor for the control of source stability can be positioned outside the reaction chamber, provided that it has been calibrated with a reference radiometric sensor placed inside the reactor. Irradiance can be