

---

---

**Timekeeping instruments — Crowns and  
sealed tubes — Designs and dimensions**

*Instruments horaires — Couronnes et tubes étanches — Constructions  
et dimensions*

**iTeh STANDARD PREVIEW**  
**(standards.iteh.ai)**

[ISO 10552:2012](https://standards.iteh.ai/catalog/standards/sist/0ab6e194-b1c4-4519-b19a-6b735bd8f068/iso-10552-2012)

<https://standards.iteh.ai/catalog/standards/sist/0ab6e194-b1c4-4519-b19a-6b735bd8f068/iso-10552-2012>



## iTeh STANDARD PREVIEW (standards.iteh.ai)

[ISO 10552:2012](https://standards.iteh.ai/catalog/standards/sist/0ab6e194-b1c4-4519-b19a-6b735bd8f068/iso-10552-2012)

<https://standards.iteh.ai/catalog/standards/sist/0ab6e194-b1c4-4519-b19a-6b735bd8f068/iso-10552-2012>



### **COPYRIGHT PROTECTED DOCUMENT**

© ISO 2012

All rights reserved. Unless otherwise specified, no part of this publication may be reproduced or utilized in any form or by any means, electronic or mechanical, including photocopying and microfilm, without permission in writing from either ISO at the address below or ISO's member body in the country of the requester.

ISO copyright office  
Case postale 56 • CH-1211 Geneva 20  
Tel. + 41 22 749 01 11  
Fax + 41 22 749 09 47  
E-mail [copyright@iso.org](mailto:copyright@iso.org)  
Web [www.iso.org](http://www.iso.org)

Published in Switzerland

## Foreword

ISO (the International Organization for Standardization) is a worldwide federation of national standards bodies (ISO member bodies). The work of preparing International Standards is normally carried out through ISO technical committees. Each member body interested in a subject for which a technical committee has been established has the right to be represented on that committee. International organizations, governmental and non-governmental, in liaison with ISO, also take part in the work. ISO collaborates closely with the International Electrotechnical Commission (IEC) on all matters of electrotechnical standardization.

International Standards are drafted in accordance with the rules given in the ISO/IEC Directives, Part 2.

The main task of technical committees is to prepare International Standards. Draft International Standards adopted by the technical committees are circulated to the member bodies for voting. Publication as an International Standard requires approval by at least 75 % of the member bodies casting a vote.

Attention is drawn to the possibility that some of the elements of this document may be the subject of patent rights. ISO shall not be held responsible for identifying any or all such patent rights.

ISO 10552 was prepared by Technical Committee ISO/TC 114, *Horology*, Subcommittee SC 7, *Overall dimensions*.

This second edition cancels and replaces the first edition (ISO 10552:1999), which has been technically revised.

## iTeh STANDARD PREVIEW (standards.iteh.ai)

[ISO 10552:2012](https://standards.iteh.ai/catalog/standards/sist/0ab6e194-b1c4-4519-b19a-6b735bd8f068/iso-10552-2012)

<https://standards.iteh.ai/catalog/standards/sist/0ab6e194-b1c4-4519-b19a-6b735bd8f068/iso-10552-2012>

**iTeh STANDARD PREVIEW**  
**(standards.iteh.ai)**

ISO 10552:2012

<https://standards.iteh.ai/catalog/standards/sist/0ab6e194-b1c4-4519-b19a-6b735bd8f068/iso-10552-2012>

# Timekeeping instruments — Crowns and sealed tubes — Designs and dimensions

## 1 Scope

This International Standard specifies designs and dimensions of crowns and sealed tubes and their tolerances.

This International Standard is applicable to crowns and sealed tubes of mechanical, electromechanical and electronic wristwatches of water-resistant designs.

## 2 Normative references

The following referenced documents are indispensable for the application of this document. For dated references, only the edition cited applies. For undated references, the latest edition of the referenced document (including any amendments) applies.

ISO 286-1, *Geometrical product specifications (GPS) — ISO code system for tolerances on linear sizes — Part 1: Basis of tolerances, deviations and fits*

ISO 6426-2, *Horological vocabulary — Part 2: Technical and commercial definitions*

ISO 22810, *Horology — Water-resistant watches*

## 3 Terms and definitions

For the purposes of this document, the terms and definitions given in ISO 6426-2 apply.

## 4 Symbols

### 4.1 Crowns

- $D_1$  outer diameter of the crown (types 1, 2 and 3)
- $D_2$  diameter of the thread (types 1, 2 and 3)
- $D_3$  diameter of the crown hub (types 1, 2 and 3)
- $D_4$  diameter of reaming bore for type 4 tube
- $C$  height of the knurled surface (types 1, 2 and 3)
- $F_1$  protrusion of the crown hub (types 1 and 3)
- $F_2$  sinking of the crown hub (type 2)
- $F_3$  positional dimension of the groove (type 3)
- $H$  height of the crown (types 1, 2 and 3)
- $P_1$  depth of the crown bore for the sealed tube (types 1, 2 and 3)
- $P_2$  the tapped part shall be at least three threads long (types 1, 2 and 3)

## 4.2 Sealed tubes

- $d_1$  fitting diameter (type 1) or head diameter (types 2, 3 and 4)
- $d_2$  diameter of the hole for the winding stem (type 3)
- $d_3$  fitting diameter (types 2 and 3)
- $d_4$  diameter of the hole (types 1, 2 and 4) or of the bore (type 3) for the crown hub
- $l$  total length (types 1, 2, 3 and 4)
- $l_1$  length of protrusion of the sealed tube (type 1) or height of the head (types 2, 3 and 4)
- $l_2$  depth of the hollow for the crown hub (type 3)

## 5 Crowns and sealed tubes — Designs and dimensions

### 5.1 Crowns with one gasket

Dimensions  $C$  and  $H$  (see Figure 1) are variable depending on the customers' specifications.

Other dimensions and tolerances are specified in Tables 1 and 2. Tolerances are specified in accordance with ISO 286-1.

The minimum depth,  $P_1$ , of the crowns (see Figure 1) shall be greater than the length,  $l_1$ , of the sealing tubes (see Figure 2).

The inside diameter of the gaskets of the crowns of types 1 and 2 (see Figure 1) shall be 0,20 mm to 0,25 mm less than the diameter,  $d_1$ , of the sealing tubes of types 1, 2 and 3 (see Figure 2).

For crowns of types 1 and 2 (see Figure 1), the finished thickness after drilling ( $H$  minus  $P_2$ ) shall be not less than 0,60 mm.

For crowns of type 1 (see Figure 1), the protrusion,  $F_1$ , of the crown hubs shall be 0,50 mm (tol. js12).

For crowns of type 2 (see Figure 1), the end of the crown hubs,  $F_2$ , shall be recessed 0,10 mm (tol. js12) into the crown with tubes of types 1 and 2, and 0,20 mm (tol. js12) with tubes of type 3.

For crowns of types 1 and 2 (see Figure 1 and Table 1), the diameter of the crown hub,  $D_3$ , shall be defined as follows:

$$D_3 = d_4 - 0,08 \text{ mm, and}$$

$$D_3 \geq D_2 + 0,27 \text{ mm.}$$

For crowns of type 3 (see Figure 1 and Table 2), the protrusion,  $F_1$ , of the crown hubs shall be between 1,60 mm and 2,60 mm (tol. js12).

For crowns of type 3 (see Figure 1 and Table 3), the positional dimension,  $F_3$ , of the groove shall be between 1,40 mm and 2,00 mm (tol. js12).

### 5.2 Sealed tubes

In order to maintain a flat surface at the external tube end for types 1, 2 and 3 (see Figure 2), for dimensions  $d_1 = 1,50$  mm and 1,60 mm, the tube edge curvature shall be shifted (towards the tube end) while remaining tangent to the outer surface indicated by the diameter  $d_1$ .

Dimensions and tolerances for tubes of types 1, 2, 3 and 4 are specified in Tables 3 to 5.

For tubes with wall thicknesses of less than 0,125 mm, the tube shall be soldered.

For stepped tubes, the minimum length of step shall be not less than the stepped diameter.

The total length,  $l$ , of the tube shall be specified in each case. Values from 0,10 mm, in 0,10 mm graduations, are recommended.

The control of sealability shall be carried out on watches completed in accordance with ISO 22810.

The use of two gaskets is permissible for crowns of types 1, 2 and 3.

The following dimensions are not recommended for gold tubes:

- tubes of types 1 and 2  $d_1 = 1,50$  mm;  $d_1 = 1,60$  mm;
- tubes of type 3  $d_1 = 1,50$  mm;
- tubes of type 4  $d_1 = 1,40$  mm.

## 6 Designations

The abbreviated designation of a sealed crown is  $D_1 \times D_2 \times D_3 \times P_1 \times F_1$  type ... ISO 10552.

EXAMPLES:

4,00 × S 0,80 × 1,17 × 0,50 type 1 ISO 10552

4,00 × S 0,80 × 1,05 × 1,80 type 3 ISO 10552

The abbreviated designation of a sealed tube is  $d_1 \times l_1 \times l$  type ... ISO 10552.

EXAMPLE:

<https://standards.iteh.ai/catalog/standards/sist/0ab6e194-b1c4-4519-b19a-6b735bd8f068/iso-10552-2012>  
 2,00 × 1,90 × 3,50 type 2 ISO 10552.

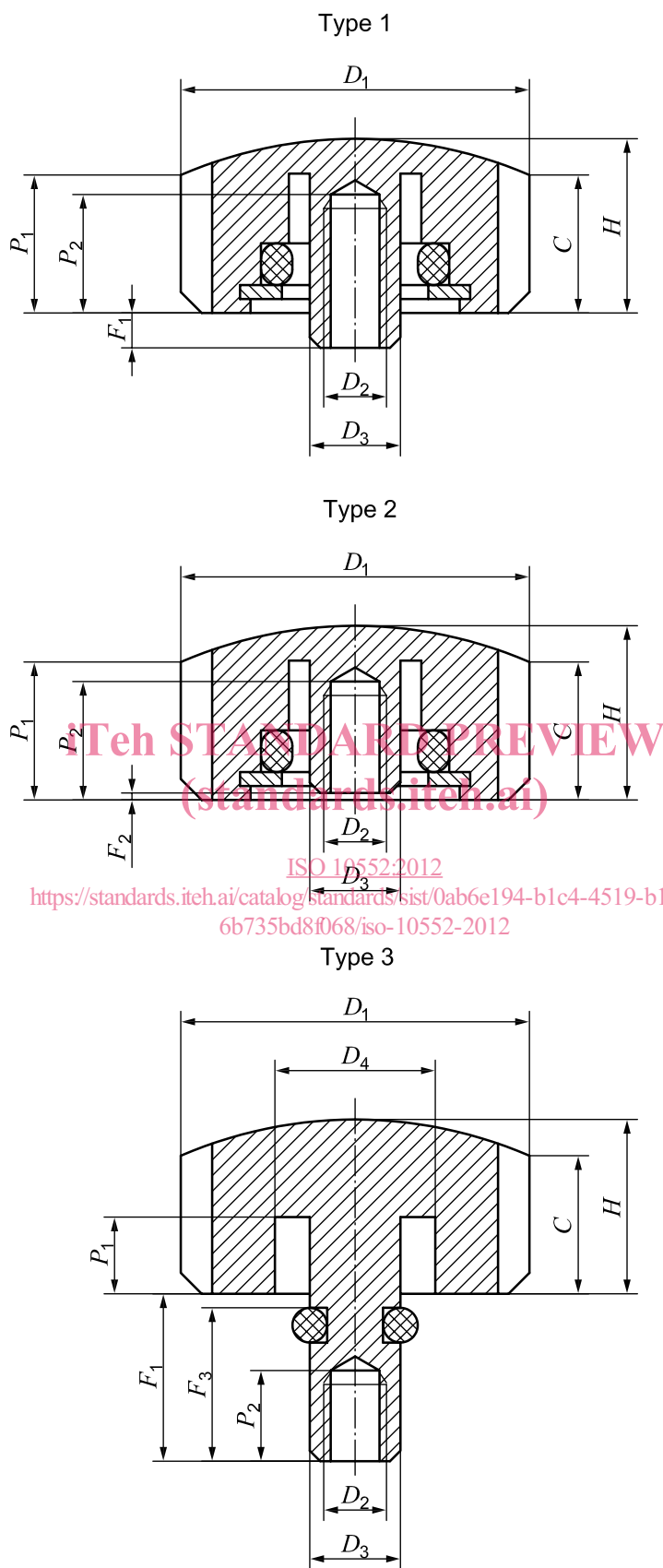

ISO 10552:2012  
<https://standards.iteh.ai/catalog/standards/sist/0ab6e194-b1c4-4519-b19a-6b735bd8f068/iso-10552-2012>

Figure 1 — Crowns



Table 1 — Crowns of types 1 and 2

Dimensions in millimetres

$D_1$	$D_2$	$P_1$
js13	—	js12
3,00	S 0,80	1,50
	S 0,90	2,00
		2,20
		2,40
3,50	S 0,80	1,50
	S 0,90	2,00
		2,20
		2,40
4,00	S 0,80	1,60
	S 0,90	2,00
	S 1,00	2,20
		2,40
4,50	S 0,90	1,60
	S 1,00	2,00
		2,20
		2,40
5,00	S 0,90	1,60
	S 1,00	2,00
		2,20
		2,40
5,50	S 0,90	1,60
	S 1,00	2,00
		2,20
		2,40
6,00	S 0,90	1,60
	S 1,00	2,00
		2,20
		2,40
6,50	S 0,90	1,60
	S 1,00	2,00
		2,20
		2,40
7,00	S 0,90	1,60
	S 1,00	2,00
		2,20
		2,40

iTeh STANDARD PREVIEW  
(standards.iteh.ai)

ISO 10552:2012  
<https://standards.iteh.ai/catalog/standards/sist/0ab6e194-b1c4-2720-b19a-6b735bd8f068/iso-10552-2012>