



**Designation: A 770/A770M – 86 (Reapproved 2001)**

## **Standard Specification for Through-Thickness Tension Testing of Steel Plates for Special Applications<sup>1</sup>**

This standard is issued under the fixed designation A 770/A770M; the number immediately following the designation indicates the year of original adoption or, in the case of revision, the year of last revision. A number in parentheses indicates the year of last reapproval. A superscript epsilon ( $\epsilon$ ) indicates an editorial change since the last revision or reapproval.

*This standard has been approved for use by agencies of the Department of Defense.*

### **1. Scope**

1.1 This specification<sup>2</sup> covers the procedures and acceptance standards for the determination of reduction of area using a tension test specimen whose axis is perpendicular to the rolled surfaces of steel plates 1 in. [25 mm] and greater in thickness. The principal purpose of the testing is to provide a measure of the resistance of a steel plate to lamellar tearing. (See Appendix X1.)

1.2 The values stated in either inch-pound units or SI units are to be regarded as standard. Within the text, the SI units are shown in brackets. The values stated in each system are not exact equivalents; therefore, each system must be used independently of the other. Combining values from the two systems may result in nonconformance with the specification.

1.3 This specification is expressed in both inch-pound and SI units. However, unless the order specifies the applicable “M” specification designation (SI units), the material shall be furnished to inch-pound units.

### **2. Referenced Documents**

#### **2.1 ASTM Standards:**

A 370 Test Methods and Definitions for Mechanical Testing of Steel Products<sup>3</sup>

### **3. Ordering Information**

3.1 The inquiry and order shall include the following, if required:

3.1.1 Supplementary requirements that are available to meet end use requirements (see S1 through S5).

3.1.2 Special requirements agreed upon between the manufacturer and the purchaser.

### **4. Tension Tests**

#### **4.1 Number of Tests:**

4.1.1 Two tests shall be required from each plate-as-rolled, except for plates subjected to heat treatment by quenching and tempering. Two tests shall be required from each quenched-and-tempered plate. The tests shall be representative of the plate in its final condition.

4.1.2 When plates are furnished by the manufacturer in an unheat-treated condition and qualified by heat-treated specimens (including normalized, normalized and tempered, and quenched and tempered), two tests shall be required from each plate-as-rolled.

NOTE 1—The term “plate-as-rolled” refers to the unit plate rolled from a slab or directly from an ingot. It does not refer to the condition of the plate.

4.2 *Location of Test Coupons*—Take one test coupon at each end of each plate as defined in 4.1. Take the test coupons from the center of the plate width.

4.3 *Orientation of Test Specimens*—The longitudinal axis of the reduced section of the test specimens shall be perpendicular to the rolled surface of the plate.

#### **4.4 Preparation of Test Specimens:**

4.4.1 *Welded Prolongations*—When required, join welded prolongations to the surface(s) of the plate being tested. The joining method used shall be one which results in a minimal heat-affected zone in the portion of the plate to be tested. Shielded metal arc, friction, stud, or electron-beam welding methods have proven to be suitable.

#### **4.4.2 Types of Test Specimens:**

4.4.2.1 Three types of standard round tension test specimens are shown in Fig. 1 and Table 1. For Types 1 and 2 specimens, locate the center of the length of the reduced section at the approximate mid-point of the plate thickness. For Type 3 specimens, locate the weld fusion line of one plate surface within ¼ in. [6 mm] of one end of the reduced section.

4.4.2.2 For plates from 1 in. [25 mm] to 1¼ in. [32 mm] inclusive in thickness, use either the 0.350-in. [8.75-mm] Type 1 specimen or the 0.500-in. [12.5-mm] Type 2 specimen.

4.4.2.3 For plates over 1¼ in. to 2 in. [50 mm] inclusive in thickness, use the 0.500-in. [12.5-mm] Type 2 specimen.

4.4.2.4 For plates greater than 2 in. [50 mm] in thickness, use the Type 3 specimen.

<sup>1</sup> This specification is under the jurisdiction of ASTM Committee A-1 on Steel, Stainless Steel, and Related Alloys and is the direct responsibility of Subcommittee A01.11 on Steel for Boilers and Pressure Vessels.

Current edition approved Feb. 28, 1986. Published April 1986. Originally published as A 770 – 80. Last previous edition A 770 – 82.

<sup>2</sup> For ASME Boiler and Pressure Vessel Code applications, see related Specification SA-770/SA-770M in Section II of that Code.

<sup>3</sup> *Annual Book of ASTM Standards*, Vol 01.03.

**ASTM A 770/A770M - 86 (2001)**

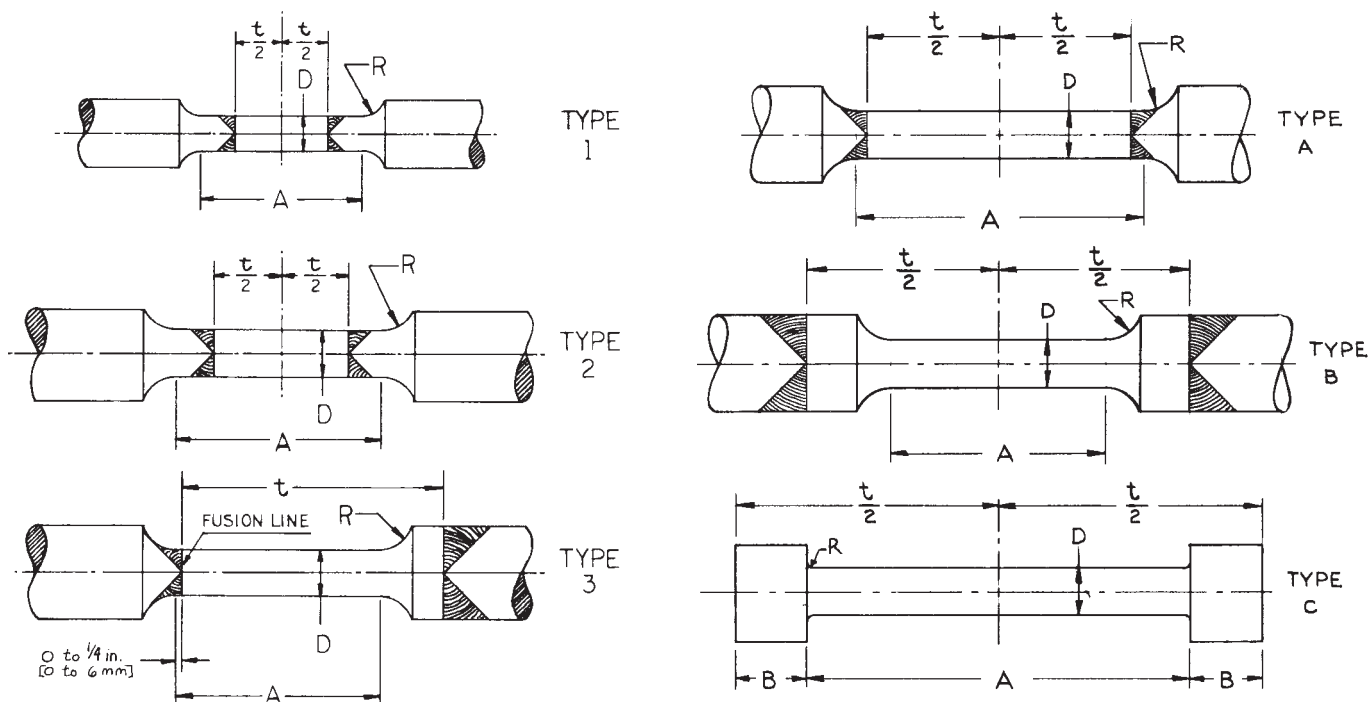

NOTE—For Type 3 only one welded prolongation may be needed, depending upon plate thickness.

**FIG. 1 Standard Round Tension Test Specimens**

**TABLE 1 Schedule of Standard Test Specimens, Inches [Millimetres]<sup>A</sup>**

	Specimen Type		
	1	2	3
Plate thickness( <i>t</i> )	1 ≤ <i>t</i> ≤ 1¼	1 < <i>t</i> ≤ 2	2 < <i>t</i>
Diameter( <i>D</i> )	0.350 [8.75]	0.500 [12.5]	0.500 [12.5]
Radius, minimum( <i>R</i> )	¼ [6]	⅜ [10]	⅝ [10]
Length of reduced section( <i>A</i> )	1¾ [45]	2¼ [60]	2¼ [60]

<sup>A</sup>See Test Methods and Definitions A 370 (Fig. 5 for further details and Fig. 6 for various types of ends).

4.4.3 *Alternative Test Specimens*—The alternative test specimens in Fig. 2 and Table 2 may be used in place of the standard specimens in Fig. 1 and Table 1, subject to agreement between the manufacturer and the purchaser.

4.4.3.1 For plates over 2 in. [50 mm] in thickness, Type A or Type B specimens may be used. The Type A specimen provides a reduced section length greater than the plate thickness. The Type B specimen provides a reduced section length of 2¼ in. [57 mm] with its center at the mid-thickness of the plate. Over a minimum plate thickness determined by the specimen end configuration, no welded prolongations may be needed for the Type B specimen. For plates over 4¼ in. [108 mm] in thickness, the standard round tension test specimen Type C may be used. For plates over 6 in. [150 mm] in thickness, a series of two or more Type A or Type C specimens with reduced sections of 4 in. [100 mm] or less may be used to cover the full thickness of the plate. The number of tests required will depend upon the thickness of the plate being tested and the reduced section length selected.

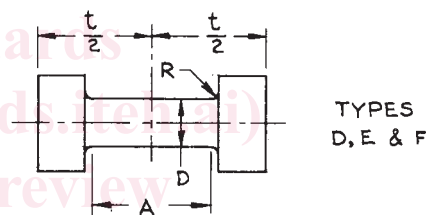

**FIG. 2 Alternative Tension Test Specimens**

4.4.3.2 For plates over 1 in. [25 mm] in thickness, a series of button-head specimens shown in Fig. 2 and Table 2 may be used. The test specimen type to be used, Type D, Type E, or Type F, is determined by the nominal plate thickness as described in Table 2. A series of two or more Type F specimens may be used to cover the full thickness of the plate. The length of the reduced section (*A*), as shown in Fig. 2 and specified in Table 2, is the length of the reduced section excluding the machined radius (*R*). Within the plate thickness dimension specified for each test specimen type, either the button-head thickness, the reduced section length, or the machined radius may be varied. In all cases, the minimum length of the reduced section must be as specified in Table 2 to maintain a minimum length to diameter ratio (see Appendix X2.2).

**5. Acceptance Standards**

5.1 Each tension test shall have a minimum reduction of area no less than 20 %. If the reduction of area of both tests is less than 20 %, no retest shall be permitted. If the reduction of area of one of the two tests from a plate is less than 20 %, one retest of two additional specimens taken from a location adjacent to the specimen that failed may be made, and both of these additional specimens shall have a reduction of area of 20 % or more.