**Polygonal taper interface with flange
contact surface —**

**Part 1:
Dimensions and designation of shanks**

Interfaces à cône polygonal avec face d'appui —

Partie 1: Dimensions et désignation des queues

**iTeh STANDARD PREVIEW
(standards.iteh.ai)**

[ISO 26623-1:2014](https://standards.iteh.ai/catalog/standards/sist/22626459-7365-441c-8ce9-32284634154c/iso-26623-1-2014)

<https://standards.iteh.ai/catalog/standards/sist/22626459-7365-441c-8ce9-32284634154c/iso-26623-1-2014>



iTeh STANDARD PREVIEW
(standards.iteh.ai)

ISO 26623-1:2014

<https://standards.iteh.ai/catalog/standards/sist/22626459-7365-441c-8ce9-32284634154c/iso-26623-1-2014>



COPYRIGHT PROTECTED DOCUMENT

© ISO 2014

All rights reserved. Unless otherwise specified, no part of this publication may be reproduced or utilized otherwise in any form or by any means, electronic or mechanical, including photocopying, or posting on the internet or an intranet, without prior written permission. Permission can be requested from either ISO at the address below or ISO's member body in the country of the requester.

ISO copyright office
Case postale 56 • CH-1211 Geneva 20
Tel. + 41 22 749 01 11
Fax + 41 22 749 09 47
E-mail copyright@iso.org
Web www.iso.org

Published in Switzerland

Contents

	Page
Foreword	iv
1 Scope	1
2 Normative references	1
3 Dimensions	1
3.1 General	1
3.2 Polygon-shanks	1
4 Clamping forces	8
5 Designation	8
Annex A (informative) Recommendations for use and application	9
Annex B (normative) Polygon shanks for stationary tools	11

iTeh STANDARD PREVIEW (standards.iteh.ai)

ISO 26623-1:2014

<https://standards.iteh.ai/catalog/standards/sist/22626459-7365-441c-8ce9-32284634154c/iso-26623-1-2014>

Foreword

ISO (the International Organization for Standardization) is a worldwide federation of national standards bodies (ISO member bodies). The work of preparing International Standards is normally carried out through ISO technical committees. Each member body interested in a subject for which a technical committee has been established has the right to be represented on that committee. International organizations, governmental and non-governmental, in liaison with ISO, also take part in the work. ISO collaborates closely with the International Electrotechnical Commission (IEC) on all matters of electrotechnical standardization.

The procedures used to develop this document and those intended for its further maintenance are described in the ISO/IEC Directives, Part 1. In particular the different approval criteria needed for the different types of ISO documents should be noted. This document was drafted in accordance with the editorial rules of the ISO/IEC Directives, Part 2 (see www.iso.org/directives).

Attention is drawn to the possibility that some of the elements of this document may be the subject of patent rights. ISO shall not be held responsible for identifying any or all such patent rights. Details of any patent rights identified during the development of the document will be in the Introduction and/or on the ISO list of patent declarations received (see www.iso.org/patents).

Any trade name used in this document is information given for the convenience of users and does not constitute an endorsement.

For an explanation on the meaning of ISO specific terms and expressions related to conformity assessment, as well as information about ISO's adherence to the WTO principles in the Technical Barriers to Trade (TBT) see the following URL: Foreword - Supplementary information

The committee responsible for this document is ISO/TC 29, *Small tools*.

This second edition cancels and replaces the first edition (ISO 26623-1:2008), which has been technically revised as follows:

— addition of polygonal shanks of nominal size 100.

ISO 26623 consists of the following parts, under the general title *Polygonal taper interface with flange contact surface*:

- *Part 1: Dimensions and designation of shanks*
- *Part 2: Dimensions and designation of receivers*

Polygonal taper interface with flange contact surface —

Part 1: Dimensions and designation of shanks

1 Scope

This part of ISO 26623 specifies dimensions for polygonal taper interfaces with flange contact surface — polygon-shanks for automatic and manual tool exchange to be applied on machine tools (e. g. turning machines, drilling machines, milling machines, and turn/milling centres, as well as grinding machines). A range of shank sizes is specified.

These shanks incorporate a grooved flange to enable automatic tool exchange. The clamping can be realized by a circular groove using clamping segments or internal screw threads using centre-bolts.

The torque is transmitted by form lock (polygon).

2 Normative references

The following documents, in whole or in part, are normatively referenced in this document and are indispensable for its application. For dated references, only the edition cited applies. For undated references, the latest edition of the referenced document (including any amendments) applies.

ISO 965-2, *ISO general purpose metric screw threads — Part 2: Limits of sizes for general purpose external and internal screw threads — Medium quality*

ISO 2768-1, *General tolerances — Part 1: Tolerances for linear and angular dimensions without individual tolerance indications*

ISO 2768-2, *General tolerances — Part 2: Geometrical tolerances for features without individual tolerance indications*

3 Dimensions

3.1 General

Tolerances for linear dimensions for features without individual tolerance indications shall be of tolerance class “m” in accordance with ISO 2768-1 and geometrical tolerances for features without individual tolerance indications shall be of tolerance class “K” in accordance with ISO 2768-2.

Tolerances for threads where tolerance is not stated shall be in accordance with ISO 965-2.

3.2 Polygon-shanks

The dimensions of polygon-shanks shall be as specified in [Figure 1](#) and [Figure 2](#) and in [Table 1](#).

NOTE Additional dimensions as in use for stationary tools are given in [Annex A](#). Additional recommendations for use and application, (i.e. balancing with a particular design for size 100), are given in [Annex B](#).

Surface roughness in micrometres
Dimensions in millimetres

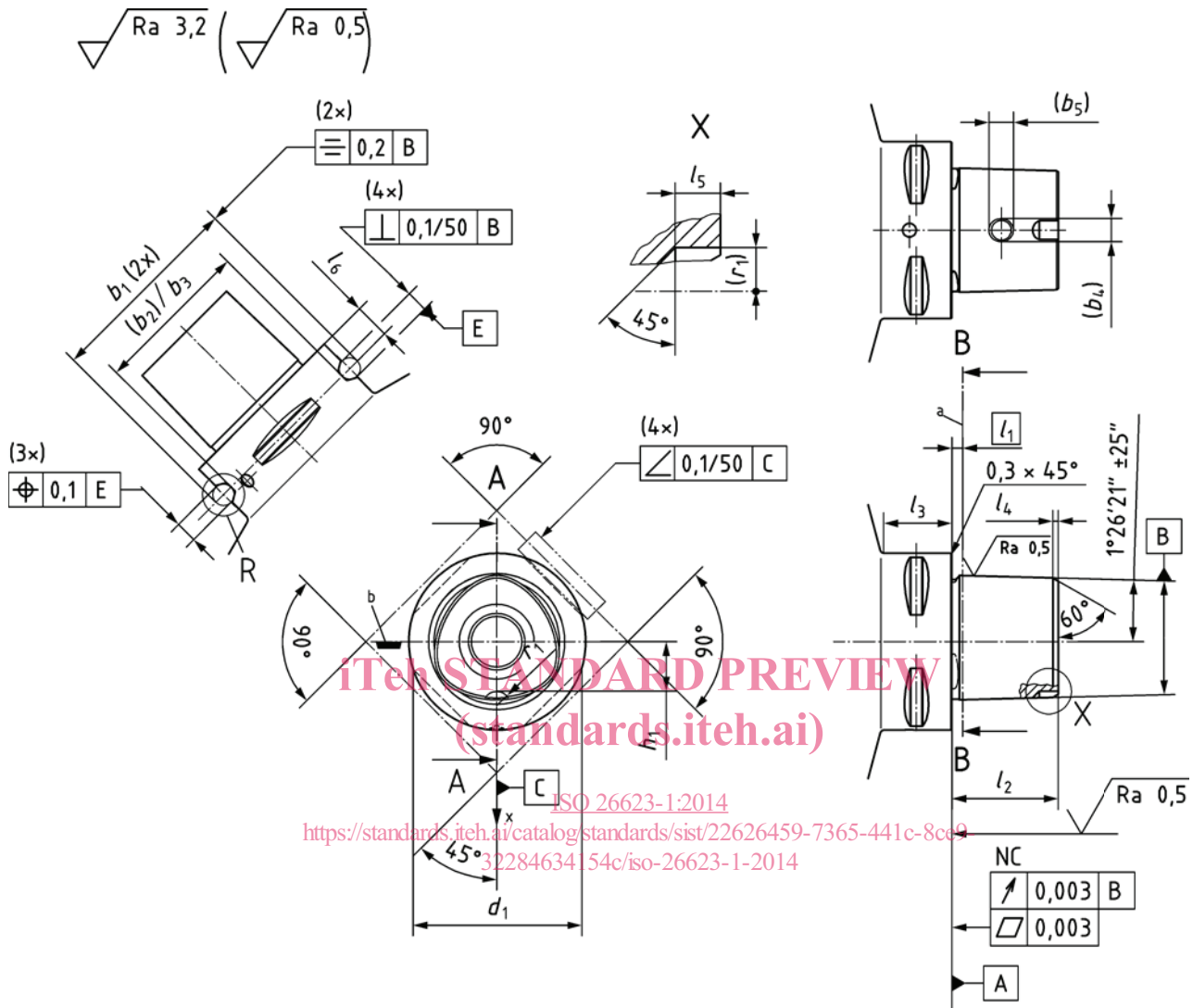

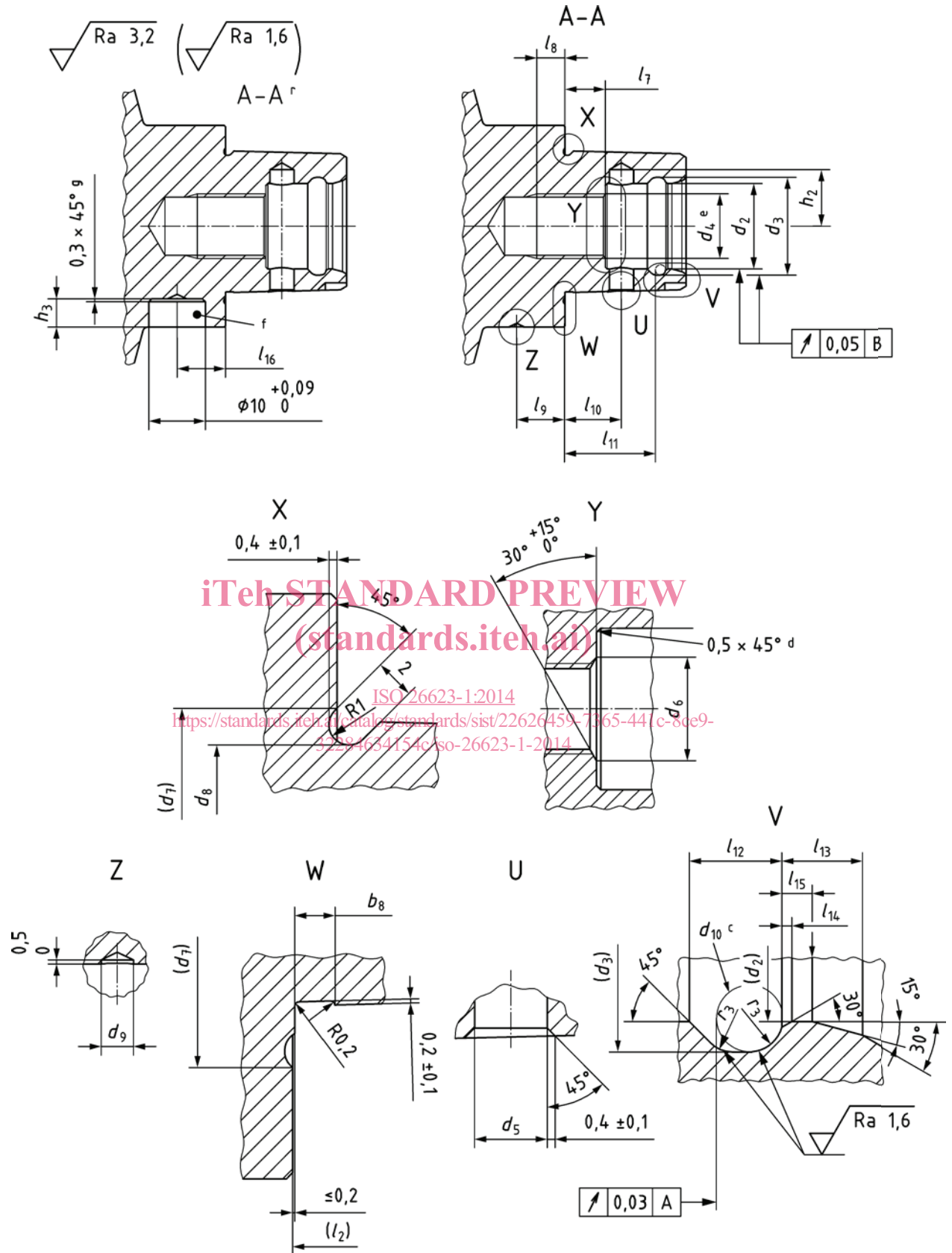

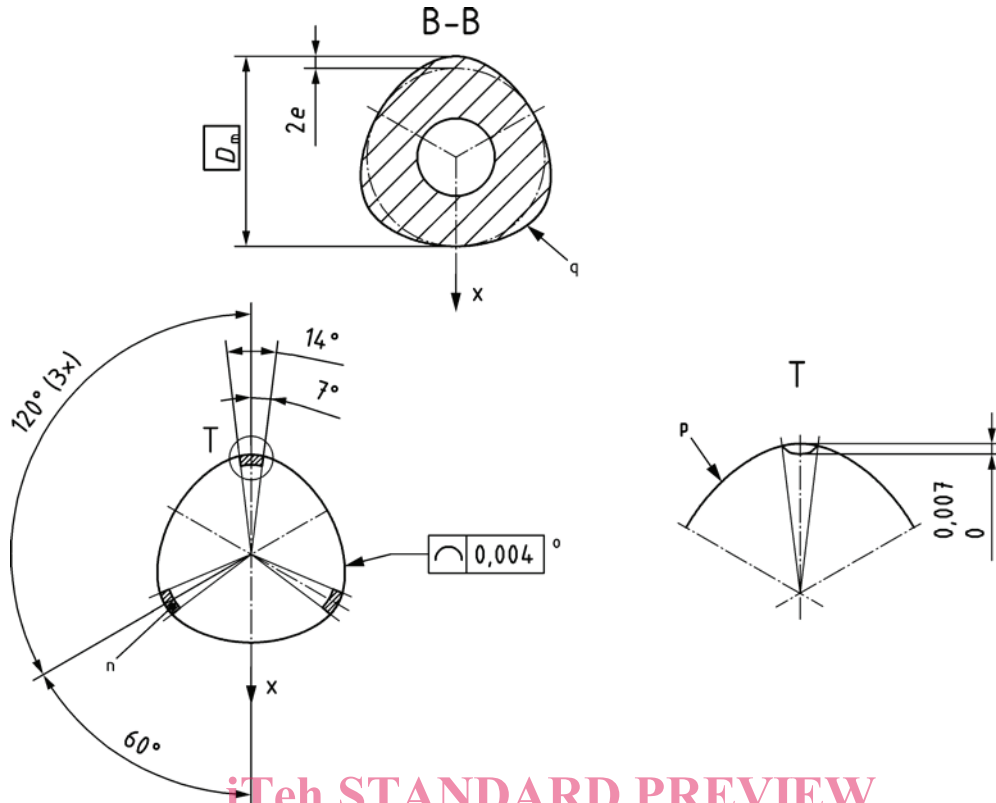

ITeh STANDARD PREVIEW
(standards.iteh.ai)

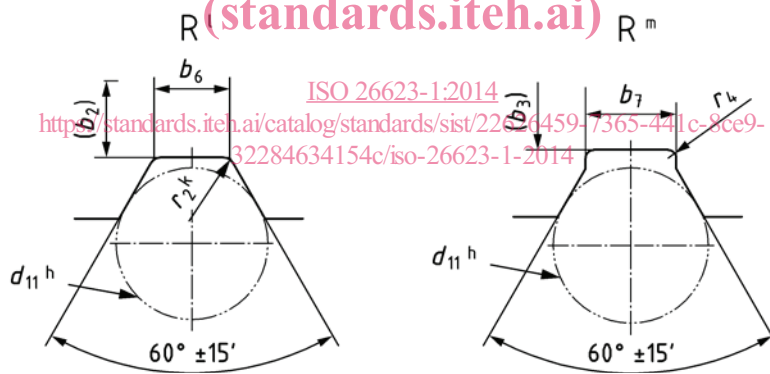

ISO 26623-1:2014
<http://standards.iteh.ai/catalog/standards/sist/22624459-7365-441c-8ce9-32284634154c/iso-26623-1-2014>

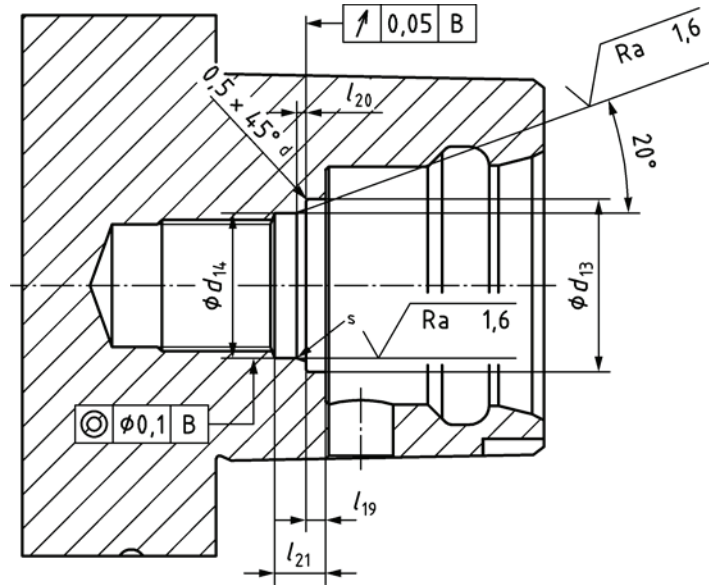

Size 100 polygon shanks

- | | | | |
|---|---|---|--|
| a | Gauge line. | k | r_2 or f_1 as alternative. |
| b | Position of the cutting edge for right hand tools with single cutting edge. | l | Detail R alternative 1. |
| c | Gauge ball. | m | Detail R alternative 2. |
| d | $0,5 \times 45^\circ$ or R 0,4. | n | Form of profile from actual ground curve = $\begin{matrix} +0 \\ -0,007 \end{matrix}$ (sectioned areas). |
| e | Thread soft. | o | Theoretical polygon curve. |
| f | Data chip hole, optional. | p | Actual ground curve. |
| g | $0,3 \times 45^\circ$ or R 0,3. | q | Polygon curve according to Figure 2 . |
| h | Gauge pin. | r | Section A-A with data chip hole, optional. |
| | | s | Rounded. |
| | | x | X-axis for theoretical polygon curve according to Figure 2 . |

Figure 1 — Polygon shanks