**Cutting tool data representation and
exchange —**

**Part 307:
Creation and exchange of 3D models
— End mills for indexable inserts**

iTeh STANDARD PREVIEW
*Représentation et échange des données relatives aux outils coupants —
Partie 307: Création et échange des modèles 3D — Fraises à
plaquettes amovibles*
(standards.iteh.ai)

ISO/TS 13399-307:2016

<https://standards.iteh.ai/catalog/standards/sist/78c4fbf6-4420-4df0-9b11-5c604c897d75/iso-ts-13399-307-2016>



iTeh STANDARD PREVIEW
(standards.iteh.ai)

ISO/TS 13399-307:2016

<https://standards.iteh.ai/catalog/standards/sist/78c4fbf6-4420-4df0-9b11-5c604c897d75/iso-ts-13399-307-2016>



COPYRIGHT PROTECTED DOCUMENT

© ISO 2016, Published in Switzerland

All rights reserved. Unless otherwise specified, no part of this publication may be reproduced or utilized otherwise in any form or by any means, electronic or mechanical, including photocopying, or posting on the internet or an intranet, without prior written permission. Permission can be requested from either ISO at the address below or ISO's member body in the country of the requester.

ISO copyright office
Ch. de Blandonnet 8 • CP 401
CH-1214 Vernier, Geneva, Switzerland
Tel. +41 22 749 01 11
Fax +41 22 749 09 47
copyright@iso.org
www.iso.org

Contents

	Page
Foreword	vi
Introduction	viii
1 Scope	1
2 Normative references	1
3 Starting elements, coordinate systems, planes	2
3.1 General.....	2
3.2 Reference system.....	2
3.3 Coordinate system at the cutting part.....	3
3.4 Planes.....	4
3.5 Design of the pocket seat and cutting reference point (CRP) of the insert.....	5
3.6 Adjustment coordinate system on workpiece side.....	8
3.6.1 General.....	8
3.6.2 Designation of the coordinate system workpiece side.....	8
4 Design of the model	9
4.1 General.....	9
4.2 Necessary parameters for the connection interface feature.....	9
4.3 Necessary properties for inserts.....	10
4.3.1 General.....	10
4.3.2 Properties for equilateral, equiangular and equilateral, non- equiangular inserts.....	10
4.3.3 Properties for non-equilateral, equiangular and non-equilateral, non- equiangular inserts.....	11
4.3.4 Design of the pocket seat feature.....	11
5 End mill, non-centre cutting, single row	11
5.1 General.....	11
5.2 Necessary properties.....	12
5.3 Basic geometry.....	13
5.4 Determination of the position of the mounting coordinate system of insert.....	13
5.5 Chip flute and pocket seat.....	14
5.6 Assembly of a single row, non-centre cutting end mill.....	15
6 Single row, non-centre cutting V-groove end mill	16
6.1 General.....	16
6.2 Necessary properties.....	17
6.3 Basic geometry.....	17
6.4 Determination of the position of the mounting coordinate system of insert.....	17
6.5 Chip flute and pocket seat.....	18
6.6 Single row, non-centre cutting V-groove end mill assembly.....	19
7 Single row, non-centre-cutting dovetail end mill	20
7.1 General.....	20
7.2 Necessary properties.....	20
7.3 Basic geometry.....	21
7.4 Determination of the position of the mounting coordinate system of insert.....	21
7.5 Chip flute and pocket seat.....	21
7.6 Single row, non-centre-cutting dovetail end mill assembly.....	22
8 T-slot end mill	22
8.1 General.....	22
8.2 Necessary properties.....	23
8.3 Basic geometry.....	23
8.4 Determination of the position of the mounting coordinate system of insert.....	23
8.5 Chip flute and pocket seat.....	24
8.6 Assembly of a T-slot end mill.....	25

9	Single row, rounded end mill	26
9.1	General.....	26
9.2	Necessary properties.....	27
9.3	Basic geometry.....	27
9.4	Determination of the position of the mounting coordinate system of insert.....	28
9.5	Chip flute and pocket seat.....	28
9.6	Assembly of a rounded end mill.....	30
10	Threading end mill	30
10.1	General.....	30
10.2	Necessary properties.....	31
10.3	Basic geometry.....	32
10.4	Determination of the position of the mounting coordinate system of insert.....	32
10.5	Chip flute and pocket seat.....	33
10.6	Assembled threading end mill.....	34
11	End mill, non-centre-cutting, multiple rows	35
11.1	General.....	35
11.2	Necessary properties.....	35
11.3	Basic geometry.....	36
11.4	Determination of the position of the mounting coordinate system of insert.....	36
11.5	Chip flute and pocket seat.....	38
11.6	Multiple rows, non-centre-cutting end mill assembly.....	39
12	Angular end mill, non-centre-cutting, multiple rows	40
12.1	General.....	40
12.2	Necessary properties.....	40
12.3	Basic geometry.....	41
12.4	Determination of the position of the mounting coordinate system of insert.....	41
12.5	Chip flute and pocket seat.....	41
12.6	Multiple rows non-centre-cutting angular end mill assembly.....	42
13	End mill, centre-cutting, multiple rows	42
13.1	General.....	42
13.2	Necessary properties.....	43
13.3	Basic geometry.....	43
13.4	Determination of the position of the mounting coordinate system of insert.....	43
13.5	Chip flute and pocket seat.....	44
13.6	Multiple rows, centre-cutting angular end mill assembly.....	45
14	Spot-facing end mill	46
14.1	General.....	46
14.2	Necessary properties.....	46
14.3	Basic geometry.....	47
14.4	Determination of the position of the mounting coordinate system of insert.....	47
14.5	Chip flute and pocket seat.....	47
14.6	Assembled spot-facing end mill.....	49
15	Straight ball-nosed end mill	49
15.1	General.....	49
15.2	Necessary properties.....	50
15.3	Basic geometry.....	50
15.4	Determination of the position of the mounting coordinate system of insert.....	51
15.5	Chip flute and pocket seat.....	52
15.6	Straight ball-nosed end mill assembly.....	53
16	Angular ball-nosed end mill	53
16.1	General.....	53
16.2	Necessary properties.....	54
16.3	Basic geometry.....	54
16.4	Determination of the position of the mounting coordinate system of insert.....	54
16.5	Chip flute and pocket seat.....	54

ITeH STANDARD PREVIEW
 (standards.iteh.ai)
 ISO/TS 13399-307:2016
<https://standards.iteh.ai/catalog/standards/sist/78c4bf6-4420-4df0-9b11-5c604c897d75/iso-ts-13399-307-2016>

16.6	Angular ball-nosed end mill assembly	54
17	Die and mould end mill	54
17.1	General	54
17.2	Necessary properties	55
17.3	Basic geometry	56
17.4	Determination of the position of the mounting coordinate system of insert	56
17.5	Chip flute and pocket seat	56
17.6	Die end mill assembly	58
18	Bell-style end mill	58
18.1	General	58
18.2	Necessary properties	59
18.3	Basic geometry	60
18.4	Determination of the position of the mounting coordinate system of insert	60
18.5	Chip flute and pocket seat	61
18.6	Bell-style end mill assembly	61
19	Design of details	61
19.1	Basis for modelling	61
19.2	Fixing threads for inserts	62
19.3	Contact/clamping surfaces — Orientation	62
19.4	Chamfers and roundings	62
20	Attributes of surfaces — Visualization of the model features	62
21	Structure of the design elements (tree of model)	62
22	Data exchange model	63
Annex A (informative) Information about nominal dimensions		65
Bibliography		66

ISO/TS 13399-307:2016

<https://standards.iteh.ai/catalog/standards/sist/78c4fbf6-4420-4df0-9b11-5c604c897d75/iso-ts-13399-307-2016>

Foreword

ISO (the International Organization for Standardization) is a worldwide federation of national standards bodies (ISO member bodies). The work of preparing International Standards is normally carried out through ISO technical committees. Each member body interested in a subject for which a technical committee has been established has the right to be represented on that committee. International organizations, governmental and non-governmental, in liaison with ISO, also take part in the work. ISO collaborates closely with the International Electrotechnical Commission (IEC) on all matters of electrotechnical standardization.

The procedures used to develop this document and those intended for its further maintenance are described in the ISO/IEC Directives, Part 1. In particular the different approval criteria needed for the different types of ISO documents should be noted. This document was drafted in accordance with the editorial rules of the ISO/IEC Directives, Part 2 (see www.iso.org/directives).

Attention is drawn to the possibility that some of the elements of this document may be the subject of patent rights. ISO shall not be held responsible for identifying any or all such patent rights. Details of any patent rights identified during the development of the document will be in the Introduction and/or on the ISO list of patent declarations received (see www.iso.org/patents).

Any trade name used in this document is information given for the convenience of users and does not constitute an endorsement.

For an explanation on the meaning of ISO specific terms and expressions related to conformity assessment, as well as information about ISO's adherence to the WTO principles in the Technical Barriers to Trade (TBT), see the following URL: [Foreword — Supplementary information](#).

The committee responsible for this document is ISO/TC 29, *Small tools*.

ISO/TS 13399 consists of the following parts, under the general title *Cutting tool data representation and exchange*:

- Part 1: *Overview, fundamental principles and general information model*
- Part 2: *Reference dictionary for the cutting items* [Technical Specification]
- Part 3: *Reference dictionary for tool items* [Technical Specification]
- Part 4: *Reference dictionary for adaptive items* [Technical Specification]
- Part 5: *Reference dictionary for assembly items* [Technical Specification]
- Part 50: *Reference dictionary for reference systems and common concepts* [Technical Specification]
- Part 60: *Reference dictionary for connection systems* [Technical Specification]
- Part 80: *Creation and exchange of 3D models — Overview and principles* [Technical Specification]
- Part 100: *Definitions, principles and methods for reference dictionaries* [Technical Specification]
- Part 150: *Usage guidelines* [Technical Specification]
- Part 201: *Creation and exchange of 3D models — Regular inserts* [Technical Specification]
- Part 202: *Creation and exchange of 3D models — Irregular inserts* [Technical Specification]
- Part 203: *Creation and exchange of 3D models — Replaceable inserts for drilling* [Technical Specification]
- Part 204: *Creation and exchange of 3D models — Inserts for reaming* [Technical Specification]
- Part 301: *Concept for the design of 3D models based on properties according to ISO/TS 13399-3: Modelling of thread-cutting taps, thread-forming taps and thread-cutting dies* [Technical Specification]

- Part 302: Concept for the design of 3D models based on properties according to ISO/TS 13399-3: Modelling of solid drills and countersinking tools [Technical Specification]
- Part 303: Concept for the design of 3D models based on properties according to ISO/TS 13399-3: Modelling of end mills with solid cutting edges [Technical Specification]
- Part 304: Concept for the design of 3D models based on properties according to ISO/TS 13399-3: Modelling of milling cutters with arbor hole and solid cutting edges [Technical Specification]
- Part 307: Creation and exchange of 3D models — End mills for indexable inserts [Technical Specification]
- Part 308: Creation and exchange of 3D models — Milling cutters with arbor hole for indexable inserts [Technical Specification]
- Part 309: Creation and exchange of 3D models — Tool holders for indexable inserts [Technical Specification]
- Part 311: Creation and exchange of 3D models — Solid reamers [Technical Specification]
- Part 312: Creation and exchange of 3D models — Reamers for indexable inserts [Technical Specification]
- Part 401: Creation and exchange of 3D models — Converting, extending and reducing adaptive items [Technical Specification]
- Part 405: Creation and exchange of 3D models — Collets [Technical Specification]

The following parts are under preparation:

- Part 70: Graphical data layout — Layer settings for tool designs [Technical Specification]
- Part 71: Graphical data layout — Creation of documents for the standardized data exchange — Graphical product information [Technical Specification]
- Part 72: Creation of documents for the standardized data exchange — Definition of properties for drawing header and their XML-data exchange [Technical Specification]
- Part 305: Creation and exchange of 3D models — Modular tooling systems with adjustable cartridges for boring [Technical Specification]
- Part 310: Creation and exchange of 3D models — Turning tools with carbide tips [Technical Specification]

Introduction

This part of ISO/TS 13399 defines the concept, the terms and the definitions on how to design simplified 3D models of end mills for indexable inserts that can be used for NC-programming, simulation of the manufacturing processes and the determination of collision within machining processes. It is not intended to standardize the design of the cutting tool itself.

A cutting tool is used in a machine to remove material from a workpiece by a shearing action at the cutting edges of the tool. Cutting tool data that can be described by ISO/TS 13399 (all parts) include, but are not limited to, everything between the workpiece and the machine tool. Information about inserts, solid tools, assembled tools, adaptors, components and their relationships can be represented by ISO/TS 13399 (all parts). The increasing demand providing the end-user with 3D models for the purposes defined above is the basis for the development of this series of International Standards.

The objective of ISO/TS 13399 (all parts) is to provide the means to represent the information that describes cutting tools in a computer sensible form that is independent from any particular computer system. The representation will facilitate the processing and exchange of cutting tool data within and between different software systems and computer platforms and support the application of this data in manufacturing planning, cutting operations and the supply of tools. The nature of this description makes it suitable not only for neutral file exchange, but also as a basis for implementing and sharing product databases and for archiving. The methods that are used for these representations are those developed by ISO/TC 184/SC 4 for the representation of product data by using standardized information models and reference dictionaries.

Definitions and identifications of dictionary entries are defined by means of standard data that consist of instances of the EXPRESS entity data types defined in the common dictionary schema, resulting from a joint effort between ISO/TC 184/SC 4 and IEC/TC 3/SC 3D, and in its extensions defined in ISO 13584-24 and ISO 13584-25.

ISO/TS 13399-307:2016

<https://standards.iteh.ai/catalog/standards/sist/78c4fbf6-4420-4df0-9b11-5c604c897d75/iso-ts-13399-307-2016>

Cutting tool data representation and exchange —

Part 307:

Creation and exchange of 3D models — End mills for indexable inserts

1 Scope

This part of ISO/TS 13399 specifies a concept for the design of tool items, limited to any kind end mills for indexable inserts, together with the usage of the related properties and domains of values.

This part of ISO/TS 13399 specifies a common way of design simplified models that contain the following:

- definitions and identifications of the design features of end mills for indexable inserts, with an association to the used properties;
- definitions and identifications of the internal structure of the 3D model that represents the features and the properties of end mills for indexable inserts.

The following are outside the scope of this part of ISO/TS 13399:

- applications where these standard data may be stored or referenced;
- concept of 3D models for cutting tools;
- concept of 3D models for cutting items;
- concept of 3D models for other tool items not being described in the scope of this International Standard;
- concept of 3D models for adaptive items;
- concept of 3D models for assembly items and auxiliary items.

2 Normative references

The following referenced documents, in whole or in part, are indispensable for the application of this document. For dated references, only the edition cited applies. For undated references, the latest edition of the referenced document (including any amendments) applies.

ISO 5610 (all parts), *Tool holders with rectangular shank for indexable inserts*

ISO/TS 13399-3, *Cutting tool data representation and exchange — Part 3: Reference dictionary for tool items*

ISO/TS 13399-4, *Cutting tool data representation and exchange — Part 4: Reference dictionary for adaptive items*

ISO/TS 13399-50, *Cutting tool data representation and exchange — Part 50: Reference dictionary for reference systems and common concepts*

ISO/TS 13399-60, *Cutting tool data representation and exchange — Part 60: Reference dictionary for connection systems*

ISO/TS 13399-80, *Cutting tool data representation and exchange — Part 80: Creation and exchange of 3D models — Overview and principles*

3 Starting elements, coordinate systems, planes

3.1 General

The modelling of the 3D models shall be done by means of nominal dimensions.

WARNING — There is no guarantee that the 3D model, created according to the methods described in this part of ISO/TS 13399, is a true representation of the physical tool supplied by the tool manufacturer. If the models are used for simulation purposes, e.g. CAM simulation, it shall be taken into consideration that the real product dimensions can differ from those nominal dimensions.

NOTE Some definitions are taken from ISO/TS 13399-50.

3.2 Reference system

The reference system consists of the following standard elements as shown in [Figure 1](#):

- **standard coordinate system** — right-handed, rectangular Cartesian system in three-dimensional space, called “primary coordinate system” (PCS);
- **three orthogonal planes** — planes in the coordinate system that contain the axis of the system, named “xy-plane” (XYP), “xz-plane” (XZP) and “yz-plane” (YZP);
- **three orthogonal axes** — axes built as intersections of the three orthogonal plane lines, respectively, named “x-axis” (XA), “y-axis” (YA) and “z-axis” (ZA).

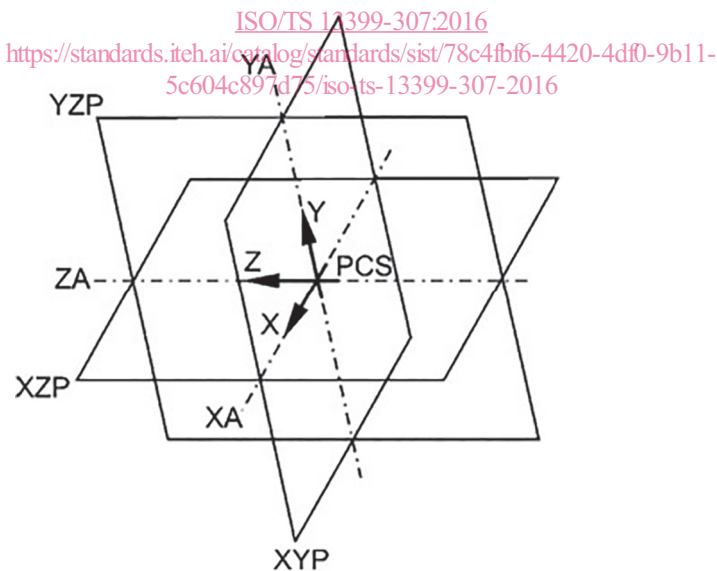

Figure 1 — Reference system

For virtually mounting end mills on to an adaptive item, an additional reference system shall be defined. This reference system shall be called “mounting coordinate system” (MCS). It is located at the starting point of the protruding length of a tool item. The orientation is shown in [Figure 2](#).

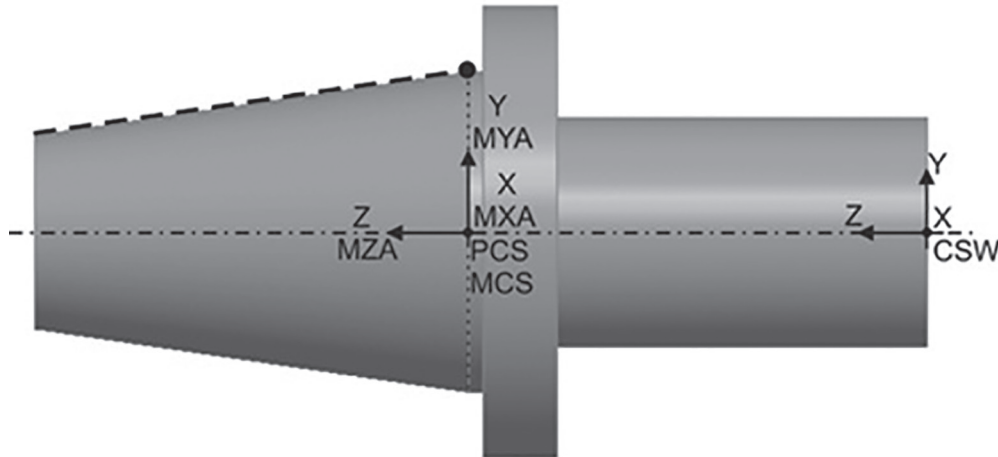

Figure 2 — Orientation of “PCS” and “MCS” reference system (example)

3.3 Coordinate system at the cutting part

The coordinate system at the cutting part, named “coordinate system in process” (CIP), with a defined distance to the PCS shall be oriented as follows:

- the origin is on a plane that is parallel to the xy-plane of PCS and is located on the most front cutting point;
- z-axis of CIP points to the PCS;
- z-axis of CIP is collinear to the z-axis of PCS;
- y-axis of CIP is parallel to the y-axis of PCS.

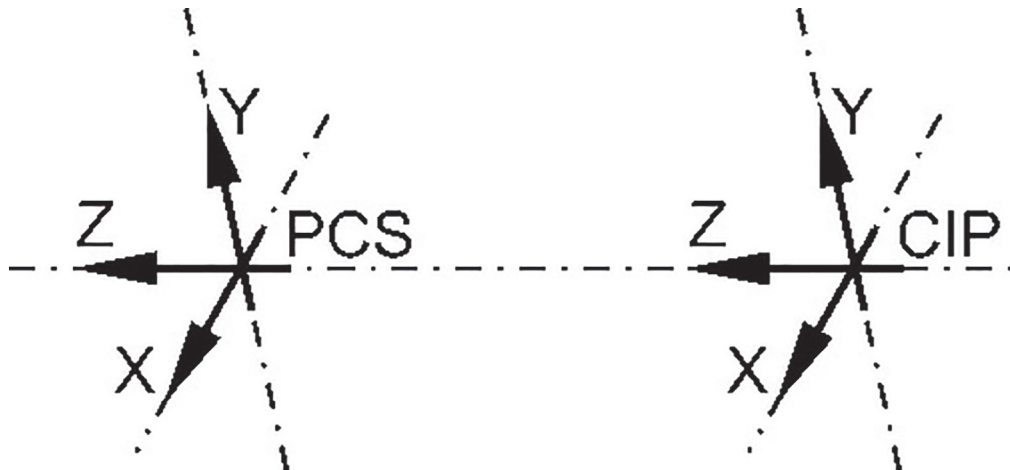

Figure 3 — Orientation of CIP

If the 3D modelling software gives the possibility to include interfaces for components to, for example, mount a front-cutting disk onto a complete cutting tool, it shall be advised to use the coordinate system “CIP”.

If necessary, another designation should be given to the interface of the component (dependent on the software). The name is “CSIF” (“coordinate system interface”) and includes the coordinate system “CIP”.

3.4 Planes

The modelling takes place based on planes according to [Figure 4](#) and shall be used as reference, if applicable. Therefore, it shall be ensured that the model is able to vary or single features of independent design features shall be suppressed by means of changing the value of one or more parameter of the model design. Furthermore, the identification of the different areas shall be simplified in using the plane concept, even if they contact each other with the same size, e.g. chip flute, shank, and so on.

For the 3D visualization of end mills for indexable inserts, the general planes shall be determined as follows and as in [Figure 4](#):

- “TEP” — the tool end plane is located at that end of the connection that points away from the workpiece; if the tool does not have a contact surface and/or a gauge line, the TEP is coplanar with the xy-plane of the PCS; the overall length (OAL) is the distance between CIP and TEP;
- “CLP” — (cutting length plane) plane for the cutting depth maximum (APMX), based on “CIP”;
- “HEP” — (head end plane) plane that determines the most front of the end mill, based on “CIP” and is coplanar to the xy-plane of CIP;
- “LHP” — plane for the head length (LH), based on “CIP”;
- “LPRP” — plane for the protruding length (LPR), based on “MCS”;
- “LSP” — plane for the shank length (LS), based on “PCS”;
- “LUP” — plane for the maximum usable length (LUX), based on “CIP”.

Other planes, if necessary, are defined in the appropriate Clauses. standards.iteh.ai

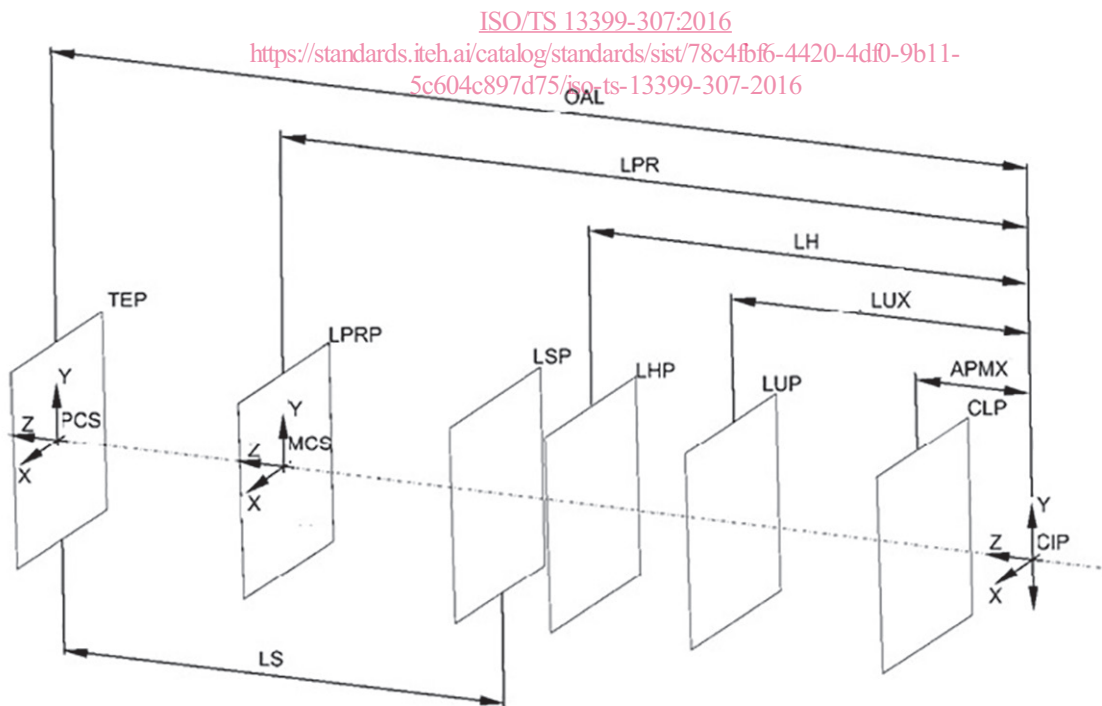

Figure 4 — Planes for design

3.5 Design of the pocket seat and cutting reference point (CRP) of the insert

NOTE If regular inserts have a specific design and are not interchangeable between vendors, the location of the MCS is at the manufacturer's discretion, either on the top face or on the bottom face. The orientation of the axis has to follow the definitions in this part of ISO/TS 13399.

The final position of the pocket seat shall be designed by means of designing an insert. This feature shall be used for subtraction from the tool body. To give the possibility to use inserts with different corner radii, only that corner defining the functional dimensions shall carry the corner radius. The remaining corners shall be designed without a corner radius.

The size of the corner radius shall meet the determination of a master radius. [Table 1](#) shows the size of the corner radii, dependent from the inscribed circle as given in ISO 5610.

Table 1 — Dependency of inscribed circle and corner radius

Dimensions in millimetres

Inscribed circle	Corner radius
3,970	0,4
4,760	0,4
5,560	0,4
6,350	0,4
9,525	0,8
12,700	0,8
15,875	1,2
19,050	1,2
22,250	2,4
25,400	2,4
31,750	2,4

NOTE At rectangular (style L) and parallelogram-shaped (styles A, B, K) inserts, the longer side that is equal to the inscribed circle determines the size of the corner radius.

MCS-coordinate system of the insert (MCS_INSERT) and the PCS-coordinate system of the insert (PCS_INSERT) are oriented differently to the primary coordinate system of the tool (PCS_TOOL). The orientation is shown in [Figures 5](#) and [7](#).

The neutral position of an insert is determined as follows.

- The origin of the MCS_INSERT shall be positioned onto the centre of the inscribed circle; at rectangular and parallelogram-shaped inserts the point of origin shall be determined through the intersection of the two diagonal lines.
- The x-axis of MCS_INSERT shall be parallel to the x-axis of PCS_INSERT.
- The y-axis of MCS_INSERT shall be parallel to the y-axis of PCS_INSERT.
- The z-axis of MCS_INSERT shall be parallel to the z-axis of PCS_INSERT.
- The x-axis of PCS_INSERT shall be collinear to the x-axis of PCS_TOOL.
- The y-axis of PCS_INSERT shall be collinear to the z-axis of PCS_TOOL.
- The Z-axis of PCS_INSERT shall be collinear to the y-axis of PCS_TOOL.

Positioning of the insert into the functional location shall be done as follows.

- a) Design with end-cutting edge angle on a right-handed tool, commonly used on the face of the end mill, typically for spot-facing cutters.
 - 1) Only inserts located in the second quadrant of the primary coordinate system of the insert, also called “left handed” inserts, shall be used.
 - 2) The insert shall be rotated by 90-KAPR degrees in mathematic positive direction (counter-clockwise) about the y-axis of the PCS_TOOL.

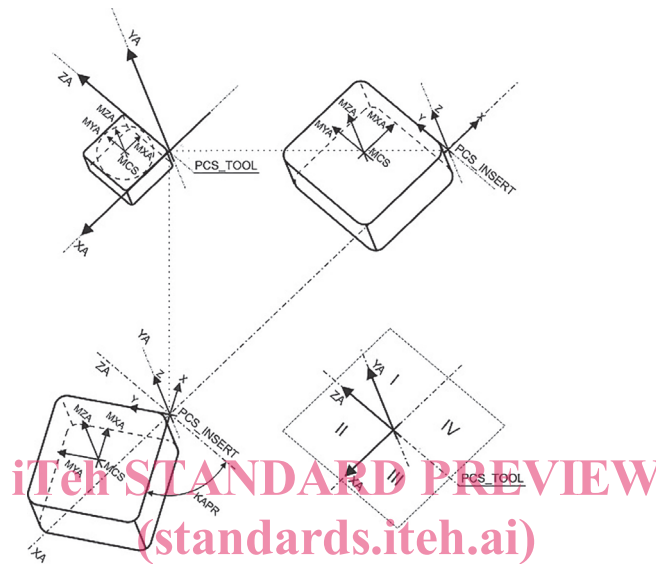

ISO/TS 13399-307:2016

Figure 5 — Orientation of PCS_INSERT, MCS_INSERT and PCS_TOOL on end cutting edge angle

5c604c897d75/iso-ts-13399-307-2016

- 3) The cutting reference point (CRP), defined in ISO/TS 13399-50, is the point where the functional dimensions are based.
- 4) The coordinate system of CRP (CS_CRP) is defined as follows:
 - i) the x-axis of CS_CRP is collinear to the x-axis of PCS_INSERT;
 - ii) the y-axis of CS_CRP is parallel to the y-axis of PCS_INSERT;
 - iii) the z-axis of CS_CRP is parallel to the z-axis of PCS_INSERT.
- 5) If the tool is defined with an axial rake and a radial rake angle that are unequal 0 degree, the insert have to be rotated about its CRP. The orientation is shown in Figure 6. Therefore, two axes shall be added:
 - i) GAMP-axis positioned on CRP with its vector that is parallel to x-axis of PCS_TOOL — defines the rotation of axial rake angle;
 - ii) GAMF-axis positioned on CRP with its vector that is parallel to z-axis of PCS_TOOL — defines the rotation of radial rake angle.

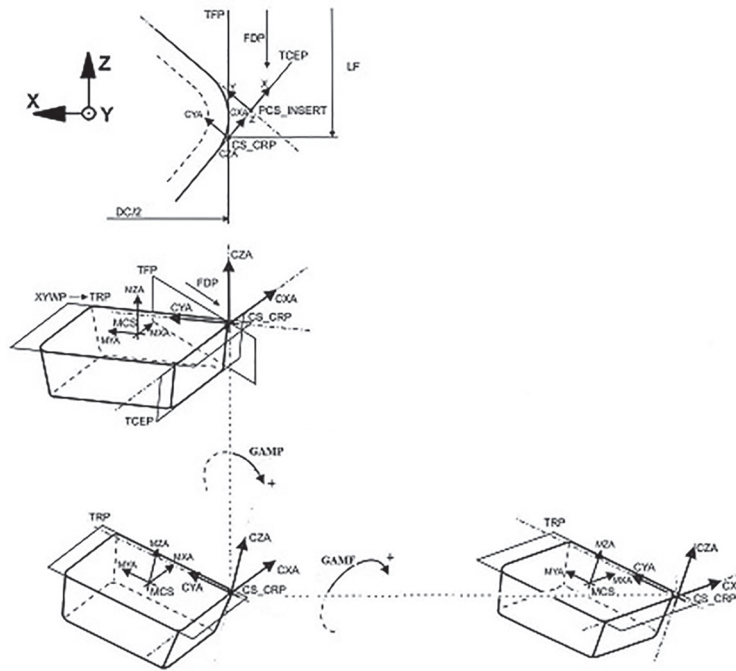

Figure 6 — Axial and radial rake angle on insert

- b) Design with side-cutting edge angle on a right-handed tool commonly used on the periphery of the end mill, typically for all kinds of side-cutting end mills.
- 1) Only inserts located in the first quadrant of the primary coordinate system of the insert, also called “right handed” or “neutral” inserts, shall be used.
 - 2) The insert shall be rotated by KAPR degrees in mathematic positive direction (counter-clockwise) about the y-axis of PCS_TOOL.

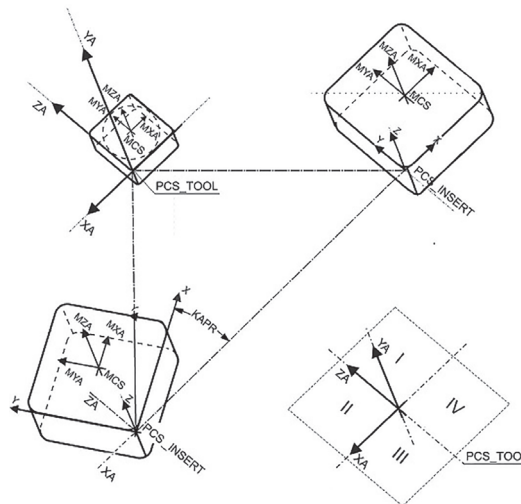

Figure 7 — Orientation of PCS_INSERT, MCS_INSERT and PCS_TOOL on side-cutting edge angle

- 3) The cutting reference point (CRP), defined in ISO/TS 13399-50, is the point where the functional dimensions are based.

The position of the C_CRP is defined with the properties DC/2 and LF.