

---

---

**Cutting tool data representation and  
exchange —**

Part 308:

**Creation and exchange of 3D models  
— Milling cutters with arbor hole for  
indexable inserts**

iTeh STANDARD PREVIEW

(standards.iteh.ai)

*Représentation et échange des données relatives aux outils coupants —  
Partie 308: Création et échange des modèles 3D — Fraises à métaux à  
trou de fixation et à plaquettes amovibles*

<https://standards.iteh.ai/catalog/standards/sist/9e26aa40-4926-4b54-abf6-204d18a89b37/iso-ts-13399-308-2016>



**iTeh STANDARD PREVIEW**  
**(standards.iteh.ai)**

[ISO/TS 13399-308:2016](https://standards.iteh.ai/catalog/standards/sist/9e26aa40-4926-4b54-abf6-204d18a89b37/iso-ts-13399-308-2016)

<https://standards.iteh.ai/catalog/standards/sist/9e26aa40-4926-4b54-abf6-204d18a89b37/iso-ts-13399-308-2016>



**COPYRIGHT PROTECTED DOCUMENT**

© ISO 2016, Published in Switzerland

All rights reserved. Unless otherwise specified, no part of this publication may be reproduced or utilized otherwise in any form or by any means, electronic or mechanical, including photocopying, or posting on the internet or an intranet, without prior written permission. Permission can be requested from either ISO at the address below or ISO's member body in the country of the requester.

ISO copyright office  
Ch. de Blandonnet 8 • CP 401  
CH-1214 Vernier, Geneva, Switzerland  
Tel. +41 22 749 01 11  
Fax +41 22 749 09 47  
copyright@iso.org  
www.iso.org

# Contents

Page

<b>Foreword</b> .....	<b>v</b>
<b>Introduction</b> .....	<b>vii</b>
<b>1 Scope</b> .....	<b>1</b>
<b>2 Normative references</b> .....	<b>1</b>
<b>3 Starting elements, coordinate systems, planes</b> .....	<b>2</b>
3.1 General.....	2
3.2 Reference system.....	2
3.3 Coordinate system at the cutting part.....	3
3.4 Planes.....	3
3.5 Design of the pocket seat and cutting reference point (CRP) of the insert.....	4
3.6 Adjustment coordinate system on workpiece side.....	7
3.6.1 General.....	7
3.6.2 Designation of the coordinate system workpiece side.....	8
<b>4 Design of the model</b> .....	<b>9</b>
4.1 General.....	9
4.2 Necessary parameters for the connection interface feature.....	10
4.3 Necessary properties for inserts.....	10
4.3.1 General.....	10
4.3.2 Properties for equilateral, equiangular and equilateral, nonequiangular inserts.....	10
4.3.3 Properties for nonequilateral, equiangular and nonequilateral, nonequiangular inserts.....	11
4.3.4 Design of the pocket seat feature.....	12
<b>5 Face milling cutter</b> .....	<b>12</b>
5.1 General.....	12
5.2 Necessary properties.....	13
5.3 Basic geometry.....	13
5.4 Determination of the position of the mounting coordinate system of insert.....	14
5.5 Chip flute and pocket seat.....	15
5.6 Face milling cutter, assembly.....	16
<b>6 Shoulder milling cutter</b> .....	<b>17</b>
6.1 General.....	17
6.2 Necessary properties.....	17
6.3 Basic geometry.....	17
6.4 Determination of the position of the mounting coordinate system of insert.....	17
6.5 Chip flute and pocket seat.....	18
6.6 Shoulder milling cutter, assembly.....	18
<b>7 Plain milling cutter</b> .....	<b>19</b>
7.1 General.....	19
7.2 Necessary properties.....	19
7.3 Basic geometry.....	20
7.4 Determination of the position of the mounting coordinate system of insert.....	20
7.5 Chip flute and pocket seat.....	21
7.6 Plain milling cutter, assembly.....	23
<b>8 Shell milling cutter</b> .....	<b>23</b>
8.1 General.....	23
8.2 Necessary properties.....	24
8.3 Basic geometry.....	24
8.4 Determination of the position of the mounting coordinate system of insert.....	25
8.5 Chip flute and pocket seat.....	25
8.6 Shell milling cutter, assembly.....	25
<b>9 Full-side-slot milling cutter</b> .....	<b>25</b>

9.1	General.....	25
9.2	Necessary properties.....	26
9.3	Basic geometry.....	26
9.4	Determination of the position of the mounting coordinate system of insert.....	27
9.5	Chip flute and pocket seat.....	28
9.6	Assembly of a full-side slot milling cutter.....	30
<b>10</b>	<b>Half-side slot milling cutter.....</b>	<b>31</b>
10.1	General.....	31
10.2	Necessary properties.....	31
10.3	Basic geometry.....	31
10.4	Determination of the position of the mounting coordinate system of insert.....	31
10.5	Chip flute and pocket seat.....	32
10.6	Half-side slot milling cutter, assembly.....	32
<b>11</b>	<b>Full-side profile slot milling cutter.....</b>	<b>33</b>
11.1	General.....	33
11.2	Necessary properties.....	33
11.3	Basic geometry.....	34
11.4	Determination of the position of the mounting coordinate system of insert.....	34
11.5	Chip flute and pocket seat.....	34
11.6	Full-side profile slot milling cutter, assembly.....	34
<b>12</b>	<b>Full-side angular slot milling cutter.....</b>	<b>35</b>
12.1	General.....	35
12.2	Necessary properties.....	35
12.3	Basic geometry.....	36
12.4	Determination of the position of the mounting coordinate system of insert.....	36
12.5	Chip flute and pocket seat.....	36
12.6	Full-side angular slot milling cutter, assembly.....	36
<b>13</b>	<b>Saw blade/slitting cutter.....</b>	<b>36</b>
13.1	General.....	36
13.2	Necessary properties.....	37
13.3	Basic geometry.....	37
13.4	Determination of the position of the mounting coordinate system of insert.....	38
13.5	Chip flute and pocket seat.....	40
13.6	Saw blade/slitting cutter, assembly.....	41
<b>14</b>	<b>Design of details.....</b>	<b>42</b>
14.1	Basics for modelling.....	42
14.2	Fixing threads for inserts.....	42
14.3	Contact surfaces/drive keys — Orientation.....	42
14.4	Chamfers, roundings, others.....	42
<b>15</b>	<b>Attributes of surfaces — Visualization of the model features.....</b>	<b>42</b>
<b>16</b>	<b>Structure of the design elements (tree of model).....</b>	<b>42</b>
<b>17</b>	<b>Data exchange model.....</b>	<b>43</b>
<b>Annex A (informative) Information about nominal dimensions.....</b>		<b>45</b>
<b>Bibliography.....</b>		<b>46</b>

ITeH STANDARD PREVIEW  
 (standards.iteh.ai)  
 ISO/TS 13399-308:2016

<https://standards.iteh.ai/catalog/standards/sist/9e26aa40-4926-4b54-abf8-204d18a89b37/iso-ts-13399-308-2016>

## Foreword

ISO (the International Organization for Standardization) is a worldwide federation of national standards bodies (ISO member bodies). The work of preparing International Standards is normally carried out through ISO technical committees. Each member body interested in a subject for which a technical committee has been established has the right to be represented on that committee. International organizations, governmental and non-governmental, in liaison with ISO, also take part in the work. ISO collaborates closely with the International Electrotechnical Commission (IEC) on all matters of electrotechnical standardization.

The procedures used to develop this document and those intended for its further maintenance are described in the ISO/IEC Directives, Part 1. In particular the different approval criteria needed for the different types of ISO documents should be noted. This document was drafted in accordance with the editorial rules of the ISO/IEC Directives, Part 2 (see [www.iso.org/directives](http://www.iso.org/directives)).

Attention is drawn to the possibility that some of the elements of this document may be the subject of patent rights. ISO shall not be held responsible for identifying any or all such patent rights. Details of any patent rights identified during the development of the document will be in the Introduction and/or on the ISO list of patent declarations received (see [www.iso.org/patents](http://www.iso.org/patents)).

Any trade name used in this document is information given for the convenience of users and does not constitute an endorsement.

For an explanation on the meaning of ISO specific terms and expressions related to conformity assessment, as well as information about ISO's adherence to the WTO principles in the Technical Barriers to Trade (TBT) see the following URL: [Foreword - Supplementary information](#)

The committee responsible for this document is ISO/TC 29, *Small tools*.

ISO/TS 13399 consists of the following parts, under the general title *Cutting tool data representation and exchange*: <https://standards.iteh.ai/catalog/standards/sist/9e26aa40-4926-4b54-abf6-204d18a89b37/iso-ts-13399-308-2016>

- *Part 1: Overview, fundamental principles and general information model*
- *Part 2: Reference dictionary for the cutting items* [Technical Specification]
- *Part 3: Reference dictionary for tool items* [Technical Specification]
- *Part 4: Reference dictionary for adaptive items* [Technical Specification]
- *Part 5: Reference dictionary for assembly items* [Technical Specification]
- *Part 50: Reference dictionary for reference systems and common concepts* [Technical Specification]
- *Part 60: Reference dictionary for connection systems* [Technical Specification]
- *Part 80: Creation and exchange of 3D models — Overview and principles* [Technical Specification]
- *Part 100: Definitions, principles and methods for reference dictionaries* [Technical Specification]
- *Part 150: Usage guidelines* [Technical Specification]
- *Part 201: Creation and exchange of 3D models — Regular inserts* [Technical Specification]
- *Part 202: Creation and exchange of 3D models — Irregular inserts* [Technical Specification]
- *Part 203: Creation and exchange of 3D models — Replaceable inserts for drilling* [Technical Specification]
- *Part 204: Creation and exchange of 3D models — Inserts for reaming* [Technical Specification]
- *Part 301: Concept for the design of 3D models based on properties according to ISO/TS 13399-3: Modelling of thread-cutting taps, thread-forming taps and thread-cutting dies* [Technical Specification]

## ISO/TS 13399-308:2016(E)

- *Part 302: Concept for the design of 3D models based on properties according to ISO/TS 13399-3: Modelling of solid drills and countersinking tools* [Technical Specification]
- *Part 303: Concept for the design of 3D models based on properties according to ISO/TS 13399-3: Modelling of end mills with solid cutting edges* [Technical Specification]
- *Part 304: Concept for the design of 3D models based on properties according to ISO/TS 13399-3: Modelling of milling cutters with arbor hole and solid cutting edges* [Technical Specification]
- *Part 307: Creation and exchange of 3D models — End mills for indexable inserts* [Technical Specification]
- *Part 308: Creation and exchange of 3D models — Milling cutters with arbor hole for indexable inserts* [Technical Specification]
- *Part 309: Creation and exchange of 3D models — Tool holders for indexable inserts* [Technical Specification]
- *Part 311: Creation and exchange of 3D models — Solid reamers* [Technical Specification]
- *Part 312: Creation and exchange of 3D models — Reamers for indexable inserts* [Technical Specification]
- *Part 401: Creation and exchange of 3D models — Converting, extending and reducing adaptive items* [Technical Specification]
- *Part 405: Creation and exchange of 3D models — Collets* [Technical Specification]

The following parts are under preparation:

- *Part 70: Graphical data layout — Layer settings for tool designs* [Technical Specification]
- *Part 71: Graphical data layout — Creation of documents for the standardized data exchange — Graphical product information* [Technical Specification]
- *Part 72: Creation of documents for the standardized data exchange — Definition of properties for drawing header and their XML-data exchange* [Technical Specification]
- *Part 305: Creation and exchange of 3D models — Modular tooling systems with adjustable cartridges for boring* [Technical Specification]
- *Part 310: Creation and exchange of 3D models — Turning tools with carbide tips* [Technical Specification]

## Introduction

This part of ISO/TS 13399 defines the concept, the terms and the definitions on how to design simplified 3D models of milling cutters with arbors hole for indexable inserts that can be used for NC-programming, simulation of the manufacturing processes and the determination of collision within machining processes. It is not intended to standardize the design of the cutting tool itself.

A cutting tool is used in a machine to remove material from a workpiece by a shearing action at the cutting edges of the tool. Cutting tool data that can be described by the ISO/TS 13399 series include, but are not limited to, everything between the workpiece and the machine tool. Information about inserts, solid tools, assembled tools, adaptors, components and their relationships can be represented by the ISO/TS 13399 series. The increasing demand providing the end-user with 3D models for the purposes defined above is the basis for the development of this series of International Standards.

The objective of this International Standard is to provide the means to represent the information that describes cutting tools in a computer sensible form that is independent from any particular computer system. The representation will facilitate the processing and exchange of cutting tool data within and between different software systems and computer platforms and support the application of this data in manufacturing planning, cutting operations and the supply of tools. The nature of this description makes it suitable not only for neutral file exchange, but also as a basis for implementing and sharing product databases and for archiving. The methods that are used for these representations are those developed by ISO/TC 184 for the representation of product data by using standardized information models and reference dictionaries.

Definitions and identifications of dictionary entries are defined by means of standard data that consist of instances of the EXPRESS entity data types defined in the common dictionary schema, resulting from a joint effort between ISO/TC 184/SC 4 and IEC/TC 3/SC 3D and in its extensions defined in ISO 13584-24 and ISO 13584-25.

[ISO/TS 13399-308:2016](https://standards.iteh.ai/catalog/standards/sist/9e26aa40-4926-4b54-abf6-204d18a89b37/iso-ts-13399-308-2016)

<https://standards.iteh.ai/catalog/standards/sist/9e26aa40-4926-4b54-abf6-204d18a89b37/iso-ts-13399-308-2016>

**iTeh STANDARD PREVIEW**  
**(standards.iteh.ai)**

[ISO/TS 13399-308:2016](https://standards.iteh.ai/catalog/standards/sist/9e26aa40-4926-4b54-abf6-204d18a89b37/iso-ts-13399-308-2016)

<https://standards.iteh.ai/catalog/standards/sist/9e26aa40-4926-4b54-abf6-204d18a89b37/iso-ts-13399-308-2016>



# Cutting tool data representation and exchange —

## Part 308:

# Creation and exchange of 3D models — Milling cutters with arbor hole for indexable inserts

## 1 Scope

This part of ISO/TS 13399 specifies a concept for the design of tool items, limited to any kind of milling cutters with arbor hole for indexable inserts, together with the usage of the related properties and domains of values.

This part of ISO/TS 13399 specifies a common way of design simplified models that contain the following:

- definitions and identifications of the design features of milling cutters with arbor hole for indexable inserts, with an association to the used properties;
- definitions and identifications of the internal structure of the 3D model that represents the features and the properties of milling cutters with arbor hole for indexable inserts.

The following are outside the scope of this part of ISO/TS 13399:

- applications where these standard data may be stored or referenced;
- concept of 3D models for cutting tools;
- concept of 3D models for cutting items;
- concept of 3D models for other tool items not being described in the scope of this part of ISO/TS 13399;
- concept of 3D models for adaptive items;
- concept of 3D models for assembly items and auxiliary items.

## 2 Normative references

The following documents, in whole or in part, are normatively referenced in this document and are indispensable for its application. For dated references, only the edition cited applies. For undated references, the latest edition of the referenced document (including any amendments) applies.

ISO 11529, *Milling cutters — Designation — Shank-type and bore-type milling cutters of solid or tipped design or with indexable cutting edges*

ISO/TS 13399-3, *Cutting tool data representation and exchange — Part 3: Reference dictionary for tool items*

ISO/TS 13399-50, *Cutting tool data representation and exchange — Part 50: Reference dictionary for reference systems and common concepts*

ISO/TS 13399-60, *Cutting tool data representation and exchange — Part 60: Reference dictionary for connection systems*

ISO/TS 13399-80, *Cutting tool data representation and exchange — Part 80: Creation and exchange of 3D models — Overview and principles*

### 3 Starting elements, coordinate systems, planes

#### 3.1 General

The modelling of the 3D models shall be done by means of nominal dimensions.

**WARNING** — There is no guarantee that the 3D model, created according to the methods described in this part of ISO/TS 13399, is a true representation of the physical tool supplied by the tool manufacturer. If the models are used for simulation purposes (e.g. CAM simulation), it shall be taken into consideration that the real product dimensions can differ from those nominal dimensions.

NOTE Some of the definitions have been taken from ISO/TS 13399-50.

#### 3.2 Reference system

The reference system consists of the following standard elements as shown in [Figure 1](#):

- **standard coordinate system:** right-handed rectangular Cartesian system in three dimensional space, called “primary coordinate system” (PCS);
- **3 orthogonal planes:** planes in the coordinate system that contain the axis of the system, named “xy-plane” (XYP), “xz-plane” (XZP) and “yz-plane” (YZP);
- **3 orthogonal axis:** axes built as intersections of the 3 orthogonal planes lines respectively, named “x-axis” (XA), “y-axis” (YA) and “z-axis” (ZA).

<https://standards.iteh.ai/catalog/standards/sist/9e26aa40-4926-4b54-abf6-204d18a891a7/iso-ts-13399-308-2016>

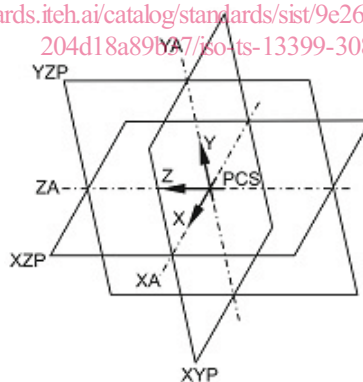

Figure 1 — Reference system

For virtually mounting of drilling and countersinking tools onto an adaptive item an additional reference system shall be defined. This reference system is called “mounting coordinate system” (MCS). It shall be located at the starting point of the protruding length of a tool item. The orientation is shown in [Figure 2](#).

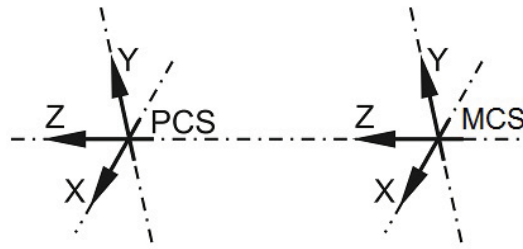

Figure 2 — Example of the orientation of “PCS” and “MCS” reference system

### 3.3 Coordinate system at the cutting part

The coordinate system at the cutting part, named “coordinate system in process” (CIP), with a defined distance to the PCS shall be oriented as follows (see [Figure 3](#)):

- the origin is on a plane that is parallel to the xy-plane of PCS and is located on the most front cutting point;
- z-axis of CIP points to the PCS;
- z-axis of CIP is collinear to the z-axis of PCS;
- y-axis of CIP is parallel to the y-axis of PCS.

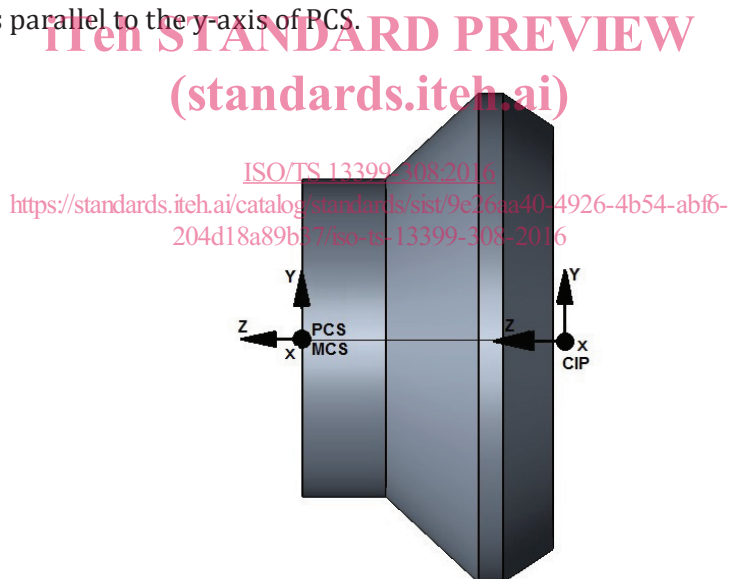

Figure 3 — Orientation of CIP

If the 3D modelling software gives the possibility to include interfaces for components to, for example, mount a front cutting disk onto a complete cutting tool, it shall be advised to use the coordinate system “CIP”.

If necessary, another designation shall be given to the interface of the component (dependent on the software). The name is “CSIF” (for “coordinate system interface”) and includes the coordinate system “CIP”.

### 3.4 Planes

The modelling shall take place based on planes according to [Figure 4](#), which shall be used as reference, if applicable. Therefore, it is assured to be able to vary the model or to suppress single features of

independent design features by means of changing the value of one or more parameter of the model design. Furthermore, the identification of the different areas shall be simplified in using the plane concept, even if they contact each other with the same size, e.g. chip flute, shank, etc.

For the 3D visualization of drilling and countersinking tools for indexable inserts, the general planes shall be determined as follows (see [Figure 4](#)):

- “TEP”: “tool end plane” is located at that end of the connection that points away from the workpiece – if the tool does not have a contact surface and/or a gauge line the TEP is coplanar with the xy-plane of the PCS. The overall length (OAL) is the distance between “CIP” and “TEP”;
- “CDP”: “cutting depth plane” for the cutting depth maximum (CDX); based on “CIP”;
- “LCCBP”: “counterbore depth connection bore plane” plane for the depth of the counterbore of the connection bore; based on “CIP”;
- “HEP”: “head end plane” is coplanar with the xy-plane of the “CIP”.

Other planes, if necessary, shall be defined in the appropriate clauses.

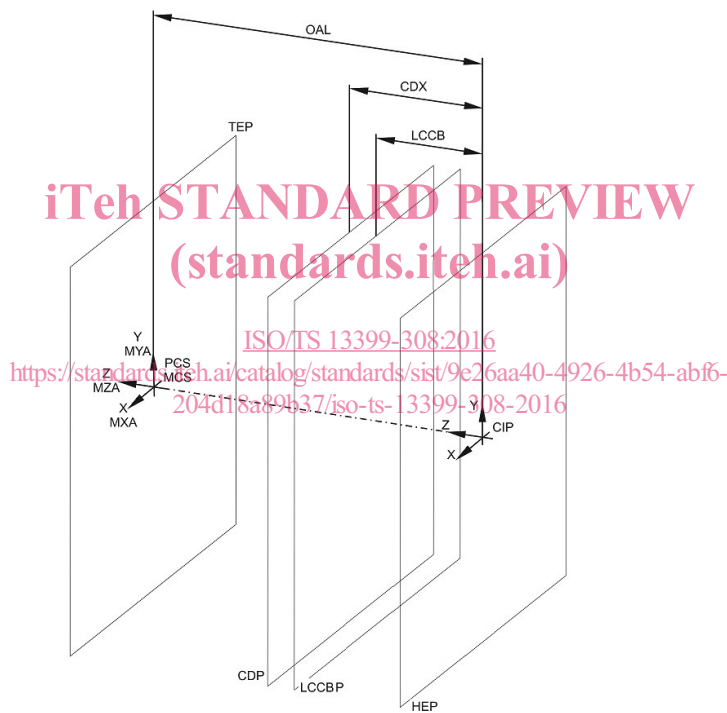

Figure 4 — Planes for design

### 3.5 Design of the pocket seat and cutting reference point (CRP) of the insert

If regular inserts have a specific design and are not interchangeable between vendors, the location of the MCS shall be left at the manufacturer’s discretion, either on the top face or on the bottom face. The orientation of the axis shall conform to this part of ISO/TS 13399.

The final position of the pocket seat shall be designed by means of designing an insert. This feature shall be used for subtraction from the tool body. To give the possibility to use inserts with different corner radii, only that corner defining the functional dimensions shall carry the corner radius; the remaining corners shall be designed without a corner radius.

The size of the corner radius shall meet the determination of a master radius. [Table 1](#) shows the size of the corner radii dependent from the inscribed circle.

**Table 1 — Dependency of inscribed circle and corner radius**

Dimensions in millimetres

Inscribed circle	Corner radius
3,970	0,4
4,760	0,4
5,560	0,4
6,350	0,4
9,525	0,8
12,700	0,8
15,875	1,2
19,050	1,2
22,250	2,4
25,400	2,4
31,750	2,4

NOTE At rectangular (style L) and parallelogram-shaped (styles A, B, K) inserts, the longer side that is equal to the inscribed circle determines the size of the corner radius.

MCS-coordinate system of the insert (MCS\_INSERT) and the PCS-coordinate system of the insert (PCS\_INSERT) are oriented differently to the primary coordinate system of the tool (PCS\_TOOL). The orientation is shown in [Figure 5](#).

The neutral position of an insert shall be determined as follows:

- the origin of the MCS\_INSERT positioned onto the centre of the inscribed circle; at rectangular and parallelogram-shaped inserts the point of origin is determined through the intersection of the two diagonal lines;
- the x-axis of MCS\_INSERT parallel to the x-axis of PCS\_INSERT;
- the y-axis of MCS\_INSERT parallel to the y-axis of PCS\_INSERT;
- the z-axis of MCS\_INSERT parallel to the z-axis of PCS\_INSERT;
- the x-axis of PCS\_INSERT collinear to the x-axis of PCS\_TOOL;
- the y-axis of PCS\_INSERT collinear to the z-axis of PCS\_TOOL;
- the z-axis of PCS\_INSERT collinear to the y-axis of PCS\_TOOL.

Positioning of the insert into the functional location shall be done as follows:

- a) Design with end cutting edge angle on a right handed tool

NOTE This design is commonly used on the face of the end mill, typically for spot facing cutters.

- Only those inserts shall be used that are located in the second quadrant of the primary coordinate system of the insert, also called “left handed” inserts.
- The insert shall be rotated by 90-KAPR degrees in mathematic positive direction (counterclockwise) about the y-axis of PCS\_TOOL.
- The cutting reference point “CRP” is the point where the functional dimensions are based. The definition of the CRP is given in ISO/TS 13399-50.
- The coordinate system of CRP (CS\_CRP) shall be defined as follows:
  - The x-axis of CS\_CRP collinear to the x-axis of PCS\_INSERT;

- The y-axis of CS\_CRP parallel to the y-axis of PCS\_INSERT;
  - The z-axis of CS\_CRP parallel to the z-axis of PCS\_INSERT.
  - If the tool is defined with an axial rake and a radial rake angle that are unequal 0 degree, the insert shall be rotated about its CRP as illustrated in [Figure 6](#). Therefore, two axis shall be added.
    - GAMP-axis positioned on CRP with its vector that is parallel to x-axis of PCS\_TOOL: defines the rotation of axial rake angle.
    - GAMF-axis positioned on CRP with its vector that is parallel to z-axis of PCS\_TOOL: defines the rotation of radial rake angle.
- b) Design with side cutting edge angle on a right handed tool as shown in [Figure 7](#), commonly used on the periphery of the end mill, typically for all kind of side cutting end mills.
- The inserts that are located in the first quadrant of the primary coordinate system of the insert, also called “right handed” or “neutral” inserts, shall only be used.
  - The insert shall be rotated by KAPR degrees in mathematic positive direction (counterclockwise) about the y-axis of PCS\_TOOL.
  - The cutting reference point “CRP” is the point where the functional dimensions are based. The definition of the CRP is given in ISO/TS 13399-50.

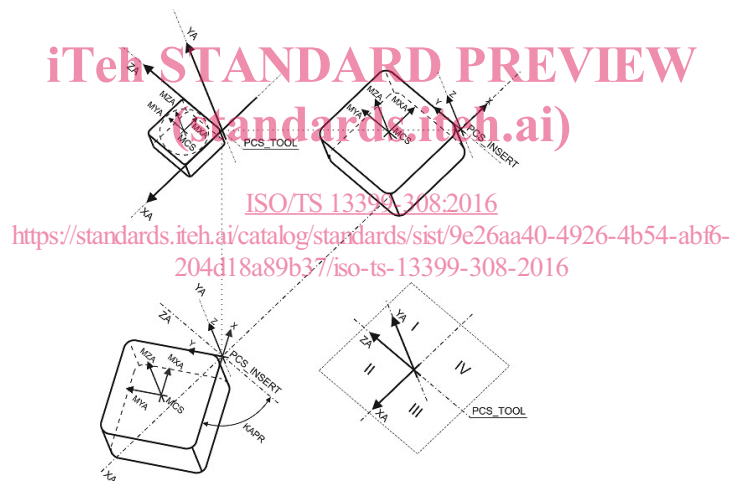

Figure 5 — Orientation of PCS\_INSERT, MCS\_INSERT and PCS\_TOOL on end cutting edge angle

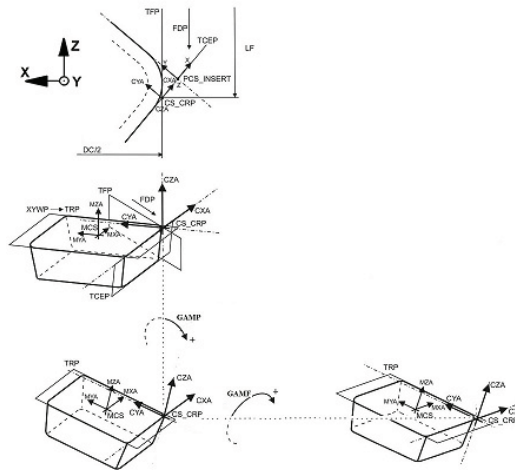

Figure 6 — Axial and radial rake angle on insert

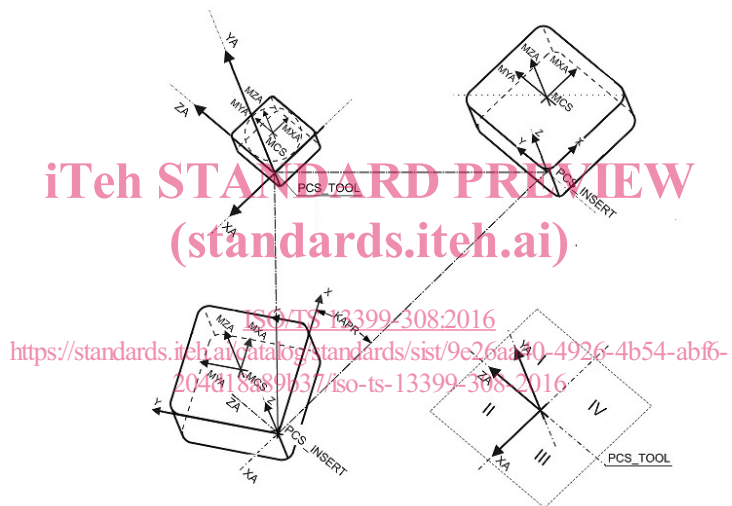

Figure 7 — Orientation of PCS\_INSERT, MCS\_INSERT and PCS\_TOOL on side cutting edge angle

### 3.6 Adjustment coordinate system on workpiece side

#### 3.6.1 General

For additional coordinate systems for mounting components, the coordinate systems “CSW<sub>x\_y</sub>” (coordinate system workpiece side) shall be defined according to ISO/TS 13399-50.