



Designation: D4923 – 01

Standard Specification for Reinforced Thermosetting Plastic Poles¹

This standard is issued under the fixed designation D4923; the number immediately following the designation indicates the year of original adoption or, in the case of revision, the year of last revision. A number in parentheses indicates the year of last reapproval. A superscript epsilon (ϵ) indicates an editorial change since the last revision or reapproval.

1. Scope*

1.1 This specification covers reinforced thermosetting plastic poles used for outdoor lighting. Such poles may be applicable to electric power and telecommunication distribution installations.

1.2 The design parameters of the poles shall be agreed upon by the purchaser and supplier and should take into consideration the anticipated service conditions of installation and transportation of the product.

1.3 This specification includes poles with above-ground or standard mounting height of 10 ft (3.05 m) through 50 ft (15.24 m). Two classes of poles are covered, one of standard design, the other of stiff design.

1.4 The values stated in inch-pound units are to be regarded as standard. Equivalent SI units are indicated in parentheses.

1.5 The following precautionary caveat pertains only to the test methods portion of this specification, Section 10: *This standard does not purport to address all of the safety problems, if any, associated with its use. It is the responsibility of the user of this standard to establish appropriate safety and health practices and determine the applicability of regulatory limitations prior to use.*

2. Referenced Documents

2.1 *ASTM Standards*:²

[A153/A153M Specification for Zinc Coating \(Hot-Dip\) on Iron and Steel Hardware](#)

[C131 Test Method for Resistance to Degradation of Small-Size Coarse Aggregate by Abrasion and Impact in the Los Angeles Machine](#)

[D149 Test Method for Dielectric Breakdown Voltage and Dielectric Strength of Solid Electrical Insulating Materials at Commercial Power Frequencies](#)

[D257 Test Methods for DC Resistance or Conductance of Insulating Materials](#)

[D635 Test Method for Rate of Burning and/or Extent and Time of Burning of Plastics in a Horizontal Position](#)

[D883 Terminology Relating to Plastics](#)

[E29 Practice for Using Significant Digits in Test Data to Determine Conformance with Specifications](#)

[E691 Practice for Conducting an Interlaboratory Study to Determine the Precision of a Test Method](#)

2.2 *AASHTO Standard*:

Standard Specifications for Structural Supports for Highway Signs, Luminaires and Traffic Signals, 1985³

3. Terminology

3.1 *Definitions: General*—All other terms not specifically defined shall be in accordance with Terminology [D883](#).

3.2 *Definitions of Terms Specific to This Standard*:

3.2.1 *anchor base*—a device attached to the bottom end of a pole designed to be mounted on an accommodating platform.

3.2.2 *arm*—a structural member, approximately perpendicular to a pole, that supports a luminaire.

3.2.3 *direct burial*—a term used to refer to a pole designed to be supported by surrounding earth (soil). (See also [3.2.9](#))

3.2.4 *effective projected area (EPA)*—maximum projected area of an object multiplied by a drag coefficient (C_d) for the specific shape of the object.

3.2.5 *flexural fatigue*—change in property(ies) of a pole as influenced by cyclical wind loading that induces flexural stresses and strains in the pole.

3.2.6 *luminaire*—a complete lighting fixture that includes light source, lens, reflector, housing, mounting provision, and may include ballast.

3.2.7 *mounting height*—the vertical distance between ground level and the center of the light source in a post top or arm-mounted luminaire.

3.2.8 *percent deflection*—the ratio (expressed in percent) of the pole-top deflection caused by a specific load to the above-ground height of the pole.

¹ This specification is under the jurisdiction of ASTM Committee D20 on Plastics and is the direct responsibility of Subcommittee D20.18 on Reinforced Thermosetting Plastics.

Current edition approved Feb. 10, 2001. Published April 2001. Originally published as D4923-89. Last previous edition D4923-92. DOI: 10.1520/D4923-01.

² For referenced ASTM standards, visit the ASTM website, www.astm.org, or contact ASTM Customer Service at service@astm.org. For *Annual Book of ASTM Standards* volume information, refer to the standard's Document Summary page on the ASTM website.

³ Available from the American Association of State Highway and Transportation Officials, 444 North Capitol St N.W., Washington, DC 20001.

*A Summary of Changes section appears at the end of this standard.

3.2.9 *pole*—a reinforced thermosetting plastic shaft that includes provisions for installing a luminaire or arm(s) and is provided with service access and wire entry holes (if required).

3.2.10 *S-1 soil*—a soil that will effectively anchor a direct burial pole in the ground and resist environmental conditions.⁴

3.2.11 *service access (or hand hole)*—a covered opening in the pole, the axis of which is perpendicular to the axis of the pole and located above ground level, that provides access to internal wiring and wire splices.

3.2.12 *shaft*—the fully cured, reinforced thermosetting plastic tubular portion of the pole before installing luminaire or attachment of fittings and cutting access holes.

3.2.13 *slip fitter*—a cylindrical receptacle in the base of a luminaire that engages a pole top tenon, or the end of an arm.

3.2.14 *surfacing veil*—a surfacing mat, as defined in Terminology **D883**, sometimes used in the outer surrounding layer of a pole to produce a smooth surface, or other desired surface characteristics.

3.2.15 *tenon*—a metal sleeve, cylinder, or other device permanently secured to, (or embedded in) the top of the pole, or the arm that inserts into the base (or slip fitter) of a luminaire.

3.2.16 *wind load*—the effect of specific wind speed acting on the pole, or all accoutrements which the pole is intended to support, expressed as a force.

NOTE 1—Wind load is derived from the wind pressure formula in **Appendix X1** using wind velocities for geographical location of the pole installation site from the Isotach chart in **Appendix X2**.

3.2.17 *wire entry*—an opening in a pole, the axis of which is perpendicular to the axis of the pole, located below ground level, that provides passage of below ground service wiring into pole cavity.

4. Classes

4.1 *Class 1*—The standard pole as determined by deflection (see **8.1.2.1**).

4.2 *Class 2*—A stiff pole as determined by deflection (see **8.1.2.2**).

5. Ordering Information

5.1 To allow pole manufacturers to determine proper pole dimensions and strength for specific applications, purchase orders and requests for quotation should provide the following information:

5.1.1 Type of pole mounting, direct burial or anchor base.

5.1.2 The luminaire mounting height and embedded depth of pole.

5.1.3 Luminaire EPA, weight, slip fitter diameter, and quantity of luminaires per pole.

5.1.4 If the luminaire will be supported by an arm(s), specify number of arms, length, rise, weight, EPA, centroid location, attachment detail, and attachment position on pole.

5.1.5 Wind speed at pole-installation site, in accordance with AASHTO Isotach Chart (see **Appendix X2**), or as otherwise specified.

⁴ National Cooperative Highway Research Program Report No. 230, March, 1981, available from Transportation Research Board, National Research Council, Washington, DC.

5.1.6 The number, size, and location of access openings.

5.1.7 Applicable local, state, and national codes.

5.1.8 Operating and maintenance practices and equipment to be used in servicing that may cause additional loads to be applied to the pole.

5.1.9 Color and finish (smooth or textured) of pole.

5.1.10 Class of pole (1 or 2).

6. Materials and Manufacture

6.1 Shaft:

6.1.1 The shaft shall be a composite of thermosetting resin, reinforced with glass or other fibers of such quantity and orientation to meet or exceed performance requirements set forth in Section **8** when installed as a pole.

6.1.2 The shaft exterior surface may have a textured pattern or a smooth finish.

7. Requirements Requirements

7.1 *Direct-Burial Poles*—The embedded end of direct-burial poles shall prevent rotation when subjected to specific torsional requirements and embedded in suitable soil. (S-1 soil shall be the referee soil.)

7.2 Base-Mounted Poles:

7.2.1 Poles designed to be mechanically fastened to ground foundations must have shafts permanently affixed to an anchor base. The total system must be capable of withstanding the combined forces for which the pole is designed.

7.2.2 The anchor-base flange shall have four radial slots to receive anchor bolts and spaced 90° on a bolt circle as agreed upon between purchaser and supplier.

7.3 *Poles Designed for Post-Top Luminaires*—Poles designed for post-top luminaires shall be provided with a permanently affixed tenon nominally 3.5 in. (8.9 cm) in length. The outside diameter shall accommodate either a 2³/₈-, 3-, or 4-in. (6.03-, 7.62-, or 10.16-cm) slip fitter as specified by the user.

NOTE 2—It is important that pole-top geometry be coordinated with fixture geometry. The pole top may require specific inside-diameter dimensions, or other modifications.

7.4 *Poles Designed for Support-Arm Application*—Poles designed for support-arm application shall be provided with a cap to close the top of the shaft. The cap shall be corrosion resistant and must remain in place when subjected to maximum wind loads for which the pole is designed.

8. Performance Requirements

8.1 The pole, with specified luminaire(s) and arm(s) installed, when exposed to winds determined in accordance with **Fig. 1** shall meet the following requirements:

NOTE 3—Unless a specific luminaire(s) and arm(s), if applicable, is (are) specified, conformance shall be based on the maximum size (EPA) luminaire and, if applicable, longest arm and maximum size (EPA) for which it is claimed that the pole is suitable at a specified wind speed.

NOTE 4—Statistical guidance established according to principles of Practices **E29** and **E691** shall be considered when determining conformance.

8.1.1 *Bending Moment*—The pole shall withstand at least one and one-half times the maximum bending moment induced

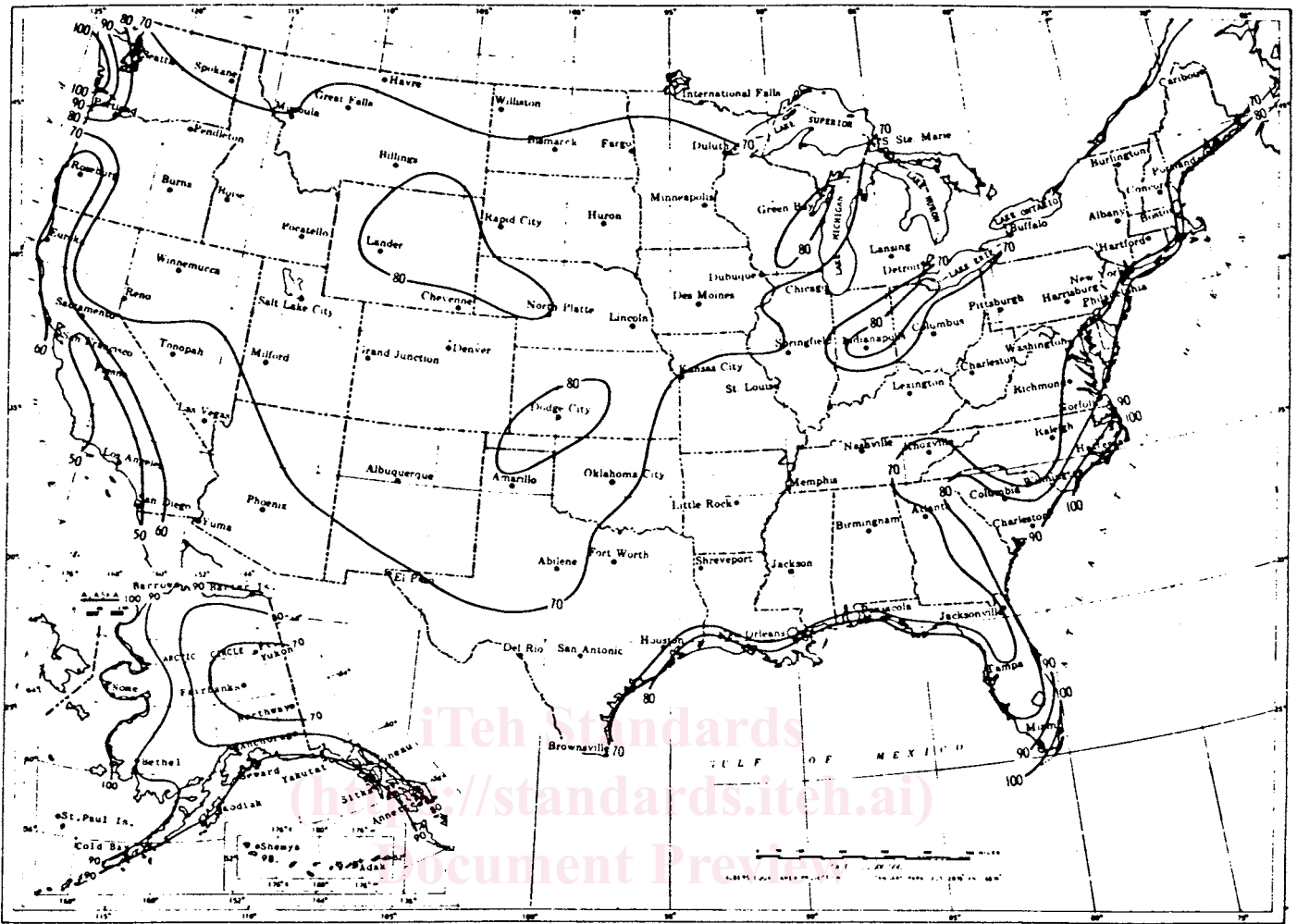

Isotach 0.04 Quantiles, in Miles Per Hour: Annual Extreme-Mile 30 Feet Above Ground, 25-Year Mean Recurrence Interval

<https://standards.iteh.ai/catalog/standards/astm-d4923-01> FIG. 1 Application of Wind Load

by the wind when tested (if applicable) in accordance with 14.1 see Appendix X1 for calculations.

8.1.2 *Pole-Top Deflection*—Poles, when tested in accordance with procedures such as described in Appendix X3, shall meet the following:

8.1.2.1 *Standard Pole (Class 1)*—The pole-top deflection induced by the wind acting on the pole and all accoutrements attached thereto shall not exceed 15 % of the above ground height.

8.1.2.2 *Stiff Pole (Class 2)*—The pole-top deflection induced by the wind acting on the pole and all accoutrements attached thereto shall not exceed 10 % of the above ground height.

8.1.3 *Torsional Moment (Applicable to Poles with Arm-Mounted Luminaires Only)*—The pole shall withstand at least one and one-half times the maximum torsional moment induced by the wind, as determined in Section 14.2. See also Appendix X4.

8.1.4 *Flexural Fatigue*—The pole shall resist degradation due to flexural fatigue, as determined in 14.3.

8.1.5 *Burn Rate*—The shaft shall not burn at a rate that exceeds 1.0 in./min (2.54 cm/min) as determined in 14.4.

8.1.6 *Conductivity*—The shaft shall be electrically nonconductive.

NOTE 5—In general, the pole shall not permit dangerous leakage currents at voltages used with commercial luminaires. Where specific insulation properties are required, these properties shall be described in such a manner that testing can be obtained in accordance with Test Methods D149 or D257.

8.1.7 *Breakaway Poles*—Requirements for breakaway poles are not a mandatory part of this specification. When agreed to between producer and consumer, such requirements shall use Section 13 as a guide.

9. Workmanship, Finish, and Appearance

9.1 There shall be no unsaturated fibers exposed on the exterior surface of the pole.

10. Wiring and Access

10.1 Wiring:

10.1.1 The pole shall permit complete internal wiring from an underground source.

10.1.2 The pole shaft shall have an inside diameter of not less than 2 in. (5.08 cm) for its entire length, except as may be

otherwise required for special top inserts. The design shall permit installation of supply conductors without damage and, for side-mounted arm installations, a minimum conductor-bending radius of 3 in. (7.62 cm).

10.2 *Wiring Access:*

10.2.1 The edges of all cut surfaces shall be smooth and all wire-entrance holes shall be sealed with resin or grommets.

10.2.2 For embedded poles, a 1.5-in. (3.81-cm) minimum minor diameter wire-entrance hole shall be located 24 in. (61 cm) below ground level, or as specified by user.

10.2.3 When specified by user, poles shall have a covered access hole of adequate size to provide access to wiring and not reduce pole strength below design values. Access holes may be circular or rectangular, with semi-circular ends. Typical sizes are given in Fig. 2.

10.2.4 Vertical location of access holes shall be as agreed upon between user and seller.

10.2.5 The radial location of access holes shall be as follows:

10.2.5.1 *Poles with Support Arm(s)*—90° clockwise from the centerline of the support arm as viewed from above unless otherwise specified by users. Poles with post-top luminaires shall be as specified by user.

10.2.6 Access hole covers shall be cast aluminum or plastic. Material must withstand environmental exposure equal to pole requirements.

10.2.7 The access hole cover must deflect driving rain and dirt from interior of pole.

10.2.8 Access hole covers shall be secured by a corrosion-resistant captive screw(s).

11. **Anchor Bolt Recommendations**

11.1 Anchor bolts and nuts should be carbon steel and have UNC Class 2A threads. A minimum of 8 in. (20.32 cm) of the threaded end of the anchor bolt and nut and washers shall be hot-dipped galvanized after fabrication, in accordance with Specification A153/A153M. Anchor bolts shall be provided with one set of nuts for leveling and one set of nuts for locking.

12. **Dimensions, Weight, and Permissible Variations**

12.1 The pole manufacturer shall determine the shaft length, based on specific embedment depth (where applicable), and luminaire mounting height. The total pole length shall be maintained within a tolerance of ±1 %.

12.2 The pole manufacturer shall determine the pole weight that will meet the strength requirements of the user's installa-

tion. Once the weight is established, weight shall be at least 95 % of the specified weight.

13. **Breakaway Poles**

13.1 *Usage*—Breakaway supports are designed to yield when struck by a vehicle, thereby minimizing injury to the occupants of the vehicle and damage to the vehicle. All new roadside signs and luminaires on high-speed highways located within the suggested clear-zone width given in the AASHTO Guide for Selecting, Locating, and Designing Traffic Barriers shall be placed on breakaway supports, unless they are located behind a barrier or crash cushion required for other reasons. Supports outside this suggested clear-zone preferably should be breakaway where there is probability of being struck by errant vehicles.

13.2 *Design*—Breakaway supports should be designed to carry loads as provided in Section 8. Dynamic performance under automobile impact also must be considered. This is best accomplished by full-scale dynamic testing, sometimes coupled with model studies or computer simulations. Satisfactory dynamic performance is indicated when the maximum change in velocity for a standard 1800-lb (816.5-kg) vehicle, or its equivalent, striking a breakaway support at speeds from 20 to 60 mph (29.33 to 88 fps) (32 to 97 km/h) does not exceed 15 fps (4.57 m/s), but preferably does not exceed 10 fps (3.05 m/s).

13.2.1 To avoid vehicle undercarriage snagging, any substantial remains of a breakaway support, when it is broken away, should not project more than 4 in. (0.102 m) above a 60-in. (1.524-m) chord aligned radially to the centerline of the highway and connecting any point, within the length of the chord, on the ground surface on one side of the support to a point on the ground surface on the other side.

13.2.2 Because of the nature of the break (in) and the nature of the reinforced (plastic) in a direct-embedded reinforced, thermosetting plastic pole,⁵ there is no relevance to the length of the stub remaining above the ground after the break.

13.2.3 Test procedures contained in the National Cooperative Highway Research Program Report 230 are appropriate for acceptance testing of breakaway supports or for a direct-embedded, reinforced thermosetting plastic pole without a support.⁵ However, the 60-mph (97-km/h) off-center impact recommended in Report 230 may be more stringent than can easily be met under the current state-of-the-art. Inasmuch as the AASHTO specification is lenient on test procedures and, over the 1975 specification, the specification calls for a 20 % reduction in the mass of the test vehicle and a 4.7 % reduction in allowable vehicle change in velocity, acceptable performance under the high-speed, off-center impact may be considered a goal and acceptance may be based on a centerline, high-speed test.

13.2.4 An approved Federal Highway Administration laboratory test using a pendulum or bogie may be substituted for the more expensive full-scale test.

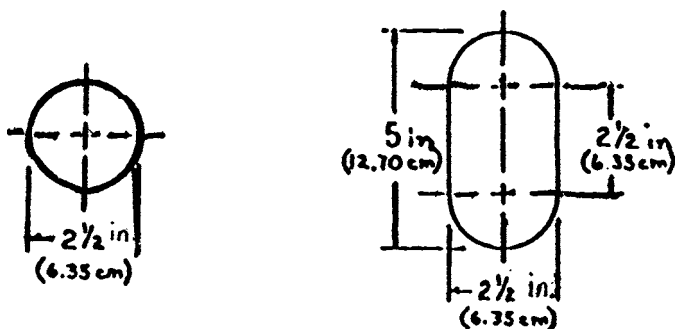

FIG. 2 Wiring Access Hole Sizes

⁵ A direct-embedded pole that does not require a breakaway support.

14. Test Methods

14.1 Bending Test—Static-bending test of poles by the cantilever method.

14.1.1 Fig. 3 depicts a typical apparatus for conducting the

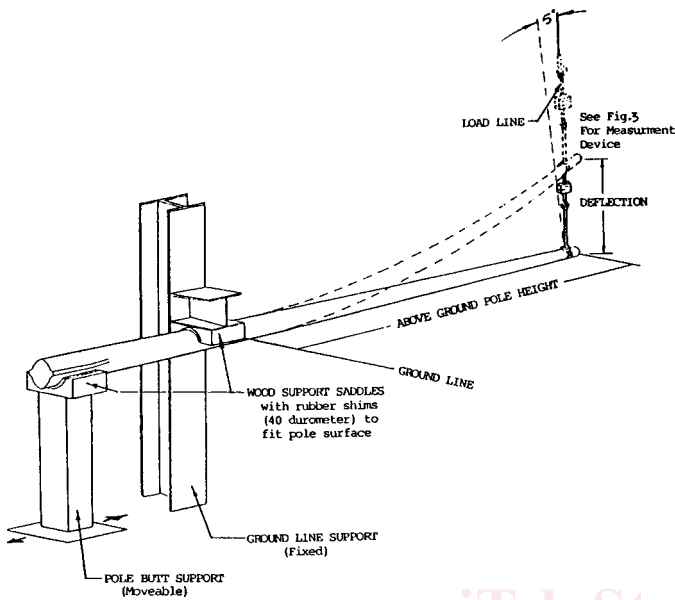

FIG. 3 Typical Bending Test Apparatus

static-bending test. Principal features of the apparatus are noted. Fig. 4 shows a device for measuring pole deflection during the test.

14.1.2 The test pole shall be held securely in a horizontal position to prevent movement at the butt and ground-line supports.

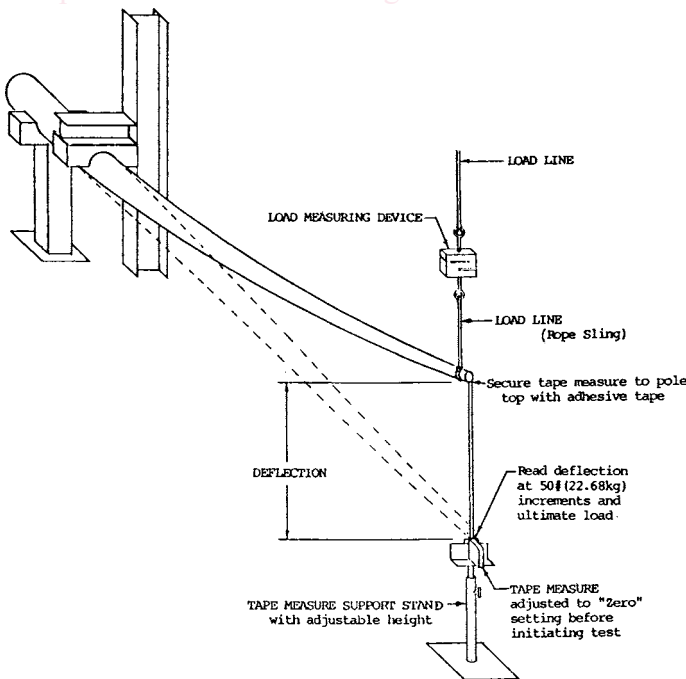

FIG. 4 Typical Pole Deflection Device

14.1.3 The load line shall be secured around the pole at the load application point 12 in. (30.48 cm) from the top of the pole.

14.1.4 The lifting point on the hoist shall be located perpendicular to the axis of the pole at the load point on the pole. The hoist line must remain perpendicular ($\pm 5^\circ$) to the original axis of the pole throughout the test.

14.1.5 A load-measuring device (dynamometer, load cell or scale), with a full scale no greater than five times the expected measurement value shall be attached in series with the hoist line. The measuring device shall be accurate to 1.0 % of the full-scale value.

14.1.6 Pole deflection shall be measured to the nearest 0.5 in. (1.27 cm), using the unloaded pole-top position as base. Measurements shall be made perpendicular ($\pm 5^\circ$) to the unloaded pole axis. Fig. 4 depicts a typical deflection-measurement device that allows deflection readings to be made a safe distance from the loaded pole during test.

14.1.7 Test Procedure:

14.1.7.1 Full in preparatory information on the Test Data Sheet (Fig. 5).

14.1.7.2 After marking designed ground-line location on pole, place pole in saddles with ground-line properly located (see Fig. 3). Rotate pole so that hand hole, with cover in place (if so equipped), is on the maximum compression surface, or,

Date _____ Recorder _____ Pole Test No. _____
 Location _____
 Weather Conditions _____ Temp _____ C
 Circumferences: Tip _____ Butt _____ GL _____
 Weight _____ Length _____ Wall Thickness at Break _____
 Butt to GL _____ GL to Load _____ Helix _____
 Manufacturer _____ Model No. _____ Material _____
 Holes (location and size) _____
 Comments _____

Dynamometer Reading (Pounds f)	Tip Datum to Load Point Deflection (Feet and Inches)	Load Point Deflection (Inches)	Ground Line Deflection	Remarks
0				
50				
100				
150				
200				
250				
300				
350				
400				
450				
500				
550				
600				
650				
700				
750				
Note				

NOTE 1—Continue in 50 lbf increments until either failure occurs or a maximum desired load is reached.

Final Deflection _____ Breaking Point _____

For Metric Conversion (or Max Load)

ft—m pounds—newtons

Inches—mm

FIG. 5 Pole Deflection Test Data Sheet

in the case of poles equipped with two opposed arms, oriented with maximum compression surface as it would be in actual service. Adjust supports and shims so that the longitudinal midpoint is level and saddles the contact surface of the pole through at least 120°.

- 14.1.7.3 Secure load line as described in 14.1.3.
- 14.1.7.4 Adjust hoist position so load line is vertical ($\pm 5^\circ$).

NOTE 6—If the hoist is positioned so that the 5° tolerance is toward the butt end of the pole, minimum adjustment to the hoist location will be required during the test. The load line must remain vertical ($\pm 5^\circ$) throughout the test.

14.1.7.5 Zero the deflection measuring device or take an initial reading that will be subtracted from subsequent measurements.

14.1.7.6 Tare load-indicating device or take an initial reading that will be subtracted from subsequent data.

14.1.7.7 Apply the load at a substantially uniform rate (*N* inches per minute) between increments until pole fails, or until a predetermined load is reached. Take deflection readings at load increments shown on the test data sheet and at failure or at a predetermined load.

14.2 Torsional Test Procedure for Poles with Arm-Mounted Luminaires:

14.2.1 This test is established to determine the torsional capabilities of a given pole/arm combination and of the attachment of the arm to the pole.

14.2.2 Mount the pole and arm in a horizontal position with the butt end secured against rotation and the tips of the pole and arm support similar to Figs. 6 and 7.

14.2.3 Locate the load attachment point, etc., at the centroid of the combined projected areas of the arm and the luminaire for which the pole is designed, or for which the pole will be used. See Appendix X5 for computation method for centroid location.

14.2.4 The direction of the test load must remain vertical $\pm 5^\circ$ throughout the test.

14.2.5 Attach a load-measuring device, as described in 14.1.5, in series with the load-application device.

14.2.6 Take a total of three deflection measurements at each load increment:

- 14.2.6.1 Vertical pole tip deflection.

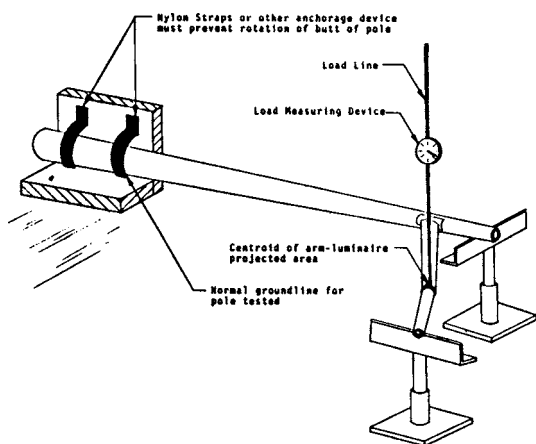

FIG. 6 Direct-Burial Torsional Test Setup

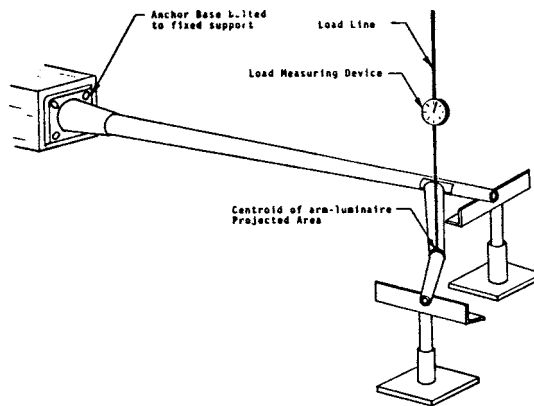

FIG. 7 Anchor-Base Torsional Test Setup

14.2.6.2 Horizontal pole tip deflection.

14.2.6.3 Vertical arm tip deflection.

14.2.6.4 Record the vertical pole tip deflection for use in Section 8 of this specification.

14.2.7 To remove the preload due to gravity, apply load until the arm tip just clears its support. At this time, either tare the load-measuring device, or record this load for subtraction from subsequent readings.

14.2.8 Apply load in predetermined increments until the structure fails, or until a predetermined load is reached (such as from wind-load analysis). At each load increment, record the deflection specified in 14.2.6.

14.2.9 Calculate the total torsional moment applied in this test.

14.2.10 Data Sheet—Keep a data sheet similar to that shown in Fig. 5 for each pole tested. Record the following data, along with any other data deemed useful by the supplier or the purchaser:

- 14.2.10.1 Date,
- 14.2.10.2 Person who performed the test,
- 14.2.10.3 Location,
- 14.2.10.4 Weather conditions,
- 14.2.10.5 Ambient temperature,
- 14.2.10.6 Pole weight,
- 14.2.10.7 Pole length,
- 14.2.10.8 Pole-mounting height,
- 14.2.10.9 Arm location with respect to pole tip,
- 14.2.10.10 Arm length/arm rise,
- 14.2.10.11 Location of load point,
- 14.2.10.12 Hand-hole size, location, and orientation with respect to load,
- 14.2.10.13 Manufacturer's name,
- 14.2.10.14 Model number,
- 14.2.10.15 Loads, and
- 14.2.10.16 Deflections.

14.3 Flexural Fatigue Test:

14.3.1 The flexural fatigue test is a method for producing repeated defined, flexural-induced strains in a pole that simulates repeated wind loading.

14.3.2 Poles in outdoor service are exposed to repeated wind loads of much lower magnitude than the maximum load for which the pole is designed.