**Vrata, okna, obešene fasade, mreže in polkna - Protivlomna odpornost -
Preskusna metoda za ugotavljanje odpornosti proti dinamičnim obremenitvam**

Pedestrian doorsets, windows, curtain walling, grilles and shutters - Burglar resistance -
Test method for the determination of resistance under dynamic loading

Türen, Fenster, Vorhangfassaden, Gitterelemente und Abschlüsse - Einbruchhemmung -
Prüfverfahren für die Ermittlung der Widerstandsfähigkeit unter dynamischer Belastung

Blocs-portes pour piétons, fenêtres, façades rideaux, grilles et fermetures - Résistance à
l'effraction - Méthode d'essai pour la détermination de la résistance à la charge
dynamique

<https://standards.iteh.ai/catalog/standards/sist/8562e1d1-9a86-4944-9ab4-1b38ed34eee9/osist-pren-1629-2019>

Ta slovenski standard je istoveten z: prEN 1629

ICS:

13.310	Varstvo pred kriminalom	Protection against crime
91.060.50	Vrata in okna	Doors and windows

oSIST prEN 1629:2019

en,fr,de

iTeh STANDARD PREVIEW
(standards.iteh.ai)

[oSIST prEN 1629:2019](#)

<https://standards.iteh.ai/catalog/standards/sist/8562e1d1-9a86-4944-9ab4-1b38ed34eee9/osist-pren-1629-2019>

EUROPEAN STANDARD
NORME EUROPÉENNE
EUROPÄISCHE NORM

DRAFT
prEN 1629

May 2019

ICS 13.310; 91.060.50

Will supersede EN 1629:2011+A1:2015

English Version

Pedestrian doorsets, windows, curtain walling, grilles and shutters - Burglar resistance - Test method for the determination of resistance under dynamic loading

Blocs-portes pour piétons, fenêtres, façades rideaux, grilles et fermetures - Résistance à l'effraction - Méthode d'essai pour la détermination de la résistance à la charge dynamique

Türen, Fenster, Vorhangfassaden, Gitterelemente und Abschlüsse - Einbruchhemmung - Prüfverfahren für die Ermittlung der Widerstandsfähigkeit unter dynamischer Belastung

This draft European Standard is submitted to CEN members for enquiry. It has been drawn up by the Technical Committee CEN/TC 33.

If this draft becomes a European Standard, CEN members are bound to comply with the CEN/CENELEC Internal Regulations which stipulate the conditions for giving this European Standard the status of a national standard without any alteration.

This draft European Standard was established by CEN in three official versions (English, French, German). A version in any other language made by translation under the responsibility of a CEN member into its own language and notified to the CEN-CENELEC Management Centre has the same status as the official versions.

CEN members are the national standards bodies of Austria, Belgium, Bulgaria, Croatia, Cyprus, Czech Republic, Denmark, Estonia, Finland, Former Yugoslav Republic of Macedonia, France, Germany, Greece, Hungary, Iceland, Ireland, Italy, Latvia, Lithuania, Luxembourg, Malta, Netherlands, Norway, Poland, Portugal, Romania, Serbia, Slovakia, Slovenia, Spain, Sweden, Switzerland, Turkey and United Kingdom.

Recipients of this draft are invited to submit, with their comments, notification of any relevant patent rights of which they are aware and to provide supporting documentation.

Warning : This document is not a European Standard. It is distributed for review and comments. It is subject to change without notice and shall not be referred to as a European Standard.



EUROPEAN COMMITTEE FOR STANDARDIZATION
COMITÉ EUROPÉEN DE NORMALISATION
EUROPÄISCHES KOMITEE FÜR NORMUNG

CEN-CENELEC Management Centre: Rue de la Science 23, B-1040 Brussels

Contents	Page
European foreword	3
1 Scope	4
2 Normative references	4
3 Terms and definitions	4
4 Apparatus	5
5 Test specimen	6
6 Procedure	7
7 Expression of results	9
8 Test report	10
Annex A (informative) Test equipment and impact points	11
A.1 Example of a test rig	11
A.2 Load impactor	12
A.3 Examples of mounting arrangements for doorsets	14
A.4 Examples of mounting arrangements for windows	18
A.5 Examples of mounting arrangements for wing and folding shutters	20
A.6 Examples of mounting arrangements for guide rails and roller shutters into the test rig	23
A.7 Examples of mounting arrangements for grilles into the test rig	28
A.8 Impact points for doors	31
A.9 Impact points for windows	33
A.10 Impact points for shutters	34
A.11 Impact points for grilles	37
Annex B (informative) Test sequence for dynamic loading test in resistance classes 1 to 3	39
Bibliography	40

European foreword

This document (prEN 1629:2019) has been prepared by Technical Committee CEN/TC 33 “Doors, windows, shutters, building hardware and curtain walling”, the secretariat of which is held by AFNOR.

This document is currently submitted to the CEN Enquiry.

This document will supersede EN 1629:2011+A1:2015.

Significant changes in this revision are:

- a) updated editions of Normative references;
- b) clarification of combined impact points in 6.2.1.

This document is one of a series of standards for burglar resistant pedestrian doorsets, windows, curtain walling, grilles and shutters. The other standards in the series are:

- prEN 1627:2019, *Pedestrian doorsets, windows, curtain walling, grilles and shutters — Burglar resistance — Requirements and classification*;
- prEN 1628:2019, *Pedestrian doorsets, windows, curtain walling, grilles and shutters – Burglar resistance – Test method for the determination of resistance under static loading*;
- prEN 1630:2019, *Pedestrian doorsets, windows, curtain walling, grilles and shutters — Burglar resistance — Test method for the determination of resistance to manual burglary attempts*.

The test described in this standard is intended to simulate physical attacks, e.g. shoulder charge, kicking.

<https://standards.iteh.ai/catalog/standards/sist/8562e1d1-9a86-4944-9ab4-1b38ed34eee9/osist-pren-1629-2019>

prEN 1629:2019 (E)**1 Scope**

This document specifies a test method for the determination of resistance to dynamic loading in order to assess the burglar resistant properties of pedestrian doorsets, windows, curtain walling, grilles and shutters. It is applicable to the following means of opening: turning, tilting, folding, turn-tilting, top or bottom hung, sliding (horizontally and vertically), pivoted (horizontally and vertically) and rolling as well as fixed constructions.

It is acknowledged that there are two aspects to the burglar resistance performance of construction products, their normal resistance to forced operation and their ability to remain fixed to the building. This test method does not evaluate the performance of the fixing to the building.

The manufacturer's installation instructions will give guidance on the fixing of the product.

An example for the contents of the manufacturer's installation instructions is given in Annex A of prEN 1627:2019.

This document does not apply to doors, gates and barriers, intended for installation in areas in the reach of persons, and for which the main intended uses are giving safe access for goods and vehicles accompanied or driven by persons in industrial, commercial or residential premises, as covered by EN 13241.

2 Normative references

The following documents, in whole or in part, are normatively referenced in this document and are indispensable for its application. For dated references, only the edition cited applies. For undated references, the latest edition of the referenced document (including any amendments) applies.

EN 356:1999, *Glass in building - Security glazing - Testing and classification of resistance against manual attack*

[oSIST prEN 1629:2019](https://standards.iteh.ai/catalog/standards/sist/8562e1d1-9a86-4944-9ab4-1b5c0342c07c/osist-pr-en-1629-2019)

prEN 1627:2019,¹⁾ *Pedestrian doorsets, windows, curtain walling, grilles and shutters — Burglar resistance — Requirements and classification*

prEN 1628:2019,²⁾ *Pedestrian doorsets, windows, curtain walling, grilles and shutters — Burglar resistance — Test method for the determination of resistance under static loading*

prEN 1630:2019,³⁾ *Pedestrian doorsets, windows, curtain walling, grilles and shutters — Burglar resistance — Test method for the determination of resistance to manual burglary attempts*

EN 12600:2002, *Glass in building - Pendulum test - Impact test method and classification for flat glass*

3 Terms and definitions

For the purposes of this document, the terms and definitions given in prEN 1627:2019 and the following apply.

ISO and IEC maintain terminological databases for use in standardization at the following addresses:

- IEC Electropedia: available at <http://www.electropedia.org/>
- ISO Online browsing platform: available at <http://www.iso.org/obp>

¹⁾ Under preparation. Stage at the time of publication: prEN 1627:2019.

²⁾ Under preparation. Stage at the time of publication: prEN 1628:2019.

³⁾ Under preparation. Stage at the time of publication: prEN 1630:2019.

3.1**test specimen**

complete, fully functioning construction product as detailed in the scope of this standard

3.2**sub-frame**

surrounding frame into which the test specimen is mounted in accordance with the manufacturer's instructions

3.3**test rig**

surrounding substantial steel frame with movable steel supports into which the sub-frames containing test specimens of various dimensions can be mounted

3.4**impacting unit**

impactor suspended by means of a suitable steel cable, as a pendulum of fixed length, with a release hook and height regulating device

3.5**impactor**

body used to strike the test specimen

3.6**impact point**

position on the surface of the test specimen where the dynamic load is applied

iTeh STANDARD PREVIEW
(standards.iteh.ai)

4 Apparatus

oSIST prEN 1629:2019

<https://standards.iteh.ai/catalog/standards/sist/8562e1d1-9a86-4944-9ab4-1b38ed34eee9/osist-pren-1629-2019>

4.1 Test rig

The test rig consisting of a rigid steel frame with movable steel supports into which test specimens of various dimensions can be mounted is shown in Annex A, Figure A.1. The stiffness of the rig shall be such that a 15 kN force applied to any of the defined points and normal to the plane of the frame will not cause a deflection of more than 5 mm and shall not affect the results of the test. The test rig shall not impede the execution of the test.

4.2 Pendulum impactor

The pendulum impactor, conforming to EN 12600:2002, is listed with individual components and pictured in Annex A, Figure A.2 and Figure A.3. The impactor shall consist of two pneumatic tyres (type 3.50 R8 4PR⁴⁾) inflated to a pressure of 0,35 MPa ± 0,02 MPa with round section and flat longitudinal tread and shall be suspended by means of a suitable steel cable giving a minimum pendulum length of 1 000 mm ± 10 mm, with a release hook and height regulating device. The tyres shall be fitted to the rims (type 250-8) of wheels that carry two steel weights of equal mass. The weights shall be dimensioned so that the total mass of the impactor is 50 kg ± 0,1 kg (excluding the steel cable and release hook) and the weights do not have any contact with the test specimen during the impact.

⁴⁾ Tyre 3.50-R8 4PR can be used for the pendulum test. Tyre 3.50-R8 4PR is the trade name of a product supplied by Vredestein BV. This information is given for the convenience of users of this European Standard and does not constitute an endorsement by CEN of the product named. Equivalent products may be used if they can be shown to lead to the same results.

prEN 1629:2019 (E)

The drop height shall be the vertical height through which the centre of gravity of the impactor falls, with a tolerance of ± 10 mm. The impactor support point shall allow the impactor to strike the test specimen at all relevant points. The complete pendulum impactor unit shall be adjustable and may be installed either on the test rig, as shown in Annex A, Figure A.1, or as an independent unit.

4.3 Suspension system

The suspension system shall conform to EN 12600:2002.

4.4 Sub-frame

The sub-frame shall simulate the support given to the product when installed into a building and shall be taken into consideration in the manufacturer's installation instructions. It shall typically consist of the following:

- a) for group 1 to group 4 products a rectangular metal tube 120 mm \times 120 mm \times 5 mm or a rectangular timber frame 100 mm \times 50 mm;
- b) additionally, for group 3 products and group 4 products a steel tube 40 mm \times 40 mm \times 3 mm and a base plate of 8 mm steel, consisting of several segments which shall be removable for the purposes of loading, if necessary.

4.5 Measuring equipment

The measuring equipment consists of the following:

- a) suitable device for measuring the drop height;
- b) equipment for determining temperature and relative humidity;
- c) gap gauge C, as shown in Figure A.14 of prEN 1628:2019;

The dimensions of the gap gauge shall have a tolerance of ± 1 mm.

5 Test specimen**5.1 General**

The test specimen shall be a functioning product complete with its frames, hardware, guide rails, curtain, tube, roller box and accessories, as appropriate.

The test specimen shall be fixed square and plumb and without twist or bend into a sub-frame. The installation shall be in accordance with the manufacturer's instructions as detailed in Clause 10 of prEN 1627:2019, including the method of fixing, packing supports, sealing requirements, etc. (see Annex A, Figures A.4 to A.20 b).

NOTE The test can be carried out with the sample mounted in a real wall or building.

For the purposes of this European Standard, the test specimen shall be glazed according to the relevant glazing resistance class of EN 356:1999, corresponding to the resistance class of the construction product according to prEN 1627:2019, as shown in Table 1 of this European Standard.

For the purpose of this test, the laminated glass shall be placed on the impact side of the product.

Table 1 — Test sample glazing requirements

Resistance class	Resistance class of glazing according to EN 356:1999
RC 1 N	P4 A
RC 2 N	P4 A
RC 2	P4 A
RC 3	P5 A

Products that use infilling other than glass shall be tested with the intended infill material. The test specimen used in the static test in accordance with prEN 1628:2019 may also be used for this test.

Products that are intended to be installed in orientations other than vertical (e.g. roof lights) shall be installed in the vertical orientation for the purpose of this test.

Should the glass break during any tests, the test programme shall proceed with the broken glass in situ. Adhesive film may be applied to the glass to protect the tester.

5.2 Preparation and examination of the test specimen

The temperature of the test specimen shall be maintained between 15 °C and 30 °C for a period of not less than 8 h prior to test.

The test specimen and sub-frame mounted in the test rig shall be visually examined for damage, defects or other particular conditions of finish, etc. These shall be recorded.

During testing, the test specimen shall be closed and locked at the declared closing condition in accordance with the manufacturer's instructions.

All locking hardware that can be disengaged from the attack side without the use of a key or tools shall be disengaged during all tests.

Products in resistance class 1 shall additionally be prepared prior to the dynamic loading test by removing all parts on the attack side that can be unscrewed, dismantled or disassembled using the tools described in prEN 1630:2019, Annex A, tool set A1. Parts shall not be damaged during this procedure. The total time for this preparation procedure shall not exceed 3 min. If the test specimen has been previously subjected to a preparation period of 3 min then it shall not be repeated.

The parts removed during this preparation shall be recorded.

6 Procedure

6.1 Test room climate

The test room temperature shall be maintained between 15 °C and 30 °C.

The relative humidity in the test room shall be between 30 % and 70 %.

6.2 Impact points, directions and test sequence

6.2.1 General

The dynamic loads specified in prEN 1627:2019, Table 13 shall be applied at the impact points and in the impact directions given in 6.2.2 and 6.2.3 as applicable, using the specified impacting unit. The impact direction shall be perpendicular to the plane of the test specimen.

Any impact points that are within 300 mm of each other shall be combined into a single impact point, mid-way between the two original impact points. No more than two impact points may be combined into a single impact point.

The test sequence shall be as given in Annex B, Figure B.1.

prEN 1629:2019 (E)**6.2.2 Group 1, Group 2 and Group 3 products****6.2.2.1 General**

For Group 1, Group 2 and Group 3 products, the impacts shall be applied once to each corner and three times to the centre of the test specimen. For test specimens without corners (circular), four points shall be selected that are approximately equidistant around the edge of the test specimen. The impact points shall be as described in 6.2.2.2 to 6.2.2.8 and, as shown in Annex A, Figures A.21 to A.27. Test specimen with more than one glazing or infilling smaller than 150 mm × 300 mm (w × h) shall be impacted three times at the centre of the glazed or infilling area. Test specimen with glazing or infillings smaller than 150 mm × 300 mm (w × h) shall not be tested.

As the dynamic test is intended to simulate physical attacks without the use of tools (e.g. shoulder blows or kicks), the impacts shall strike the product on the attack side.

6.2.2.2 Hinged doors, single or double leaf doors and sliding doors

This test shall not be performed on any door leaf or infilling of less than 150 mm width (see Annex A, Figure A.21, dimension A).

If the distance between two adjacent impact points is less than 300 mm (see Annex A, Figure A.21, dimension B), only the mid-point between those impact points shall be tested.

If the door leaf and/or infilling is narrower than 150 mm (see Annex A, Figure A.21, dimension C), the impact shall be omitted.

6.2.2.3 Double doors

Unless the applicant instructs to the contrary, both doors shall be tested. The applicant may request the test for the double door on one door only, in which case the test shall be applied as for a single-leaf door.

The inside leaf of the double door shall be fully removed to allow a complete dynamic test of the outer door. The outer door shall then be removed, and the inside door tested.

The test procedure is shown in Annex A, Figure A.22.

6.2.2.4 Side-hinged windows, sliding windows and pivot windows with one or more casements

The test shall not be performed on infillings of less than 150 mm width (see Annex A, Figure A.23, dimension A).

If the distance between two adjacent impact points is less than 300 mm (see Annex A, Figure A.23, dimension B), only the mid-point between those impact points shall be tested.

One impact shall be applied to each corner of the infilling and three impacts shall be applied to the centre of each infilling.

6.2.2.5 Single wing shutters

The test shall not be performed on infillings of less than 200 mm width (see Annex A, Figure A.24, dimension A).

If the distance between two adjacent impact points is less than 300 mm (see Annex A, Figure A.24, dimension B), only the mid-point between those impact points shall be tested.

One impact shall be applied to each corner of infilling or leaf and three impacts shall be applied to the centre of each infilling or leaf.

6.2.2.6 Multi-leaf wing shutters

Multi-leaf wing shutters shall first be impacted at the impact points on the meeting edges as shown in Annex A, Figure A.25 (V) and thereafter at the hinges as shown in Annex A, Figure A.25 (B).

All other impact points shall be tested as described in 6.2.2.2.

6.2.2.7 Folding shutters

Folding shutters shall first be impacted at the impact points on the meeting edges and thereafter at the hinges, as shown in Annex A, Figure A.26.

If all hinges are identical then a minimum of four shall be chosen and tested.

All other impact points shall be tested as described in 6.2.2.2.

6.2.2.8 Roller shutters

One impact shall be applied to each corner of the roller curtain and three impacts shall be applied to the centre of the roller curtain. The impact points are shown in Annex A, Figure A.27.

6.2.3 Group 4 products

For Group 4 products, the impacts shall be applied to the specimen as shown in Figures A.28 to A.29. Infilling openings that are smaller than gap gauge C as shown in Figure A.14 of prEN 1628:2019 shall not be tested.

One impact shall be applied to each corner of the specimen and three impacts shall be applied to the centre of the grille.

As the dynamic test is intended to simulate a physical attack in which the primary objective is to remove the product by pulling it away from the building without the use of tools, the impacts shall strike the product on the non-attack side.

The impact is always applied to the non-attack side. This test simulates the pulling of the grilles. When impacting grilles, a plate 250 mm square may be used to spread the impact and prevent damage to the impactor.

6.3 Impact test procedure

The dynamic loads specified in prEN 1627:2019 shall be applied at the impact points shown in Annex A, Figures A.21 to A.29 of this document using the pendulum impactor, which shall be raised to the appropriate drop height and stabilized. At the drop height the suspension cable shall be taut and the axis of the cable and pendulum impactor shall be in line.

The pendulum impactor shall be released and allowed to swing freely against the test specimen. If it rebounds, then the impactor shall be restrained and not allowed to strike the product for a second time. After each impact, the test specimen shall be inspected for damage and assessed for failure and any damage to the specimen shall be recorded. When using the gap gauge C to assess failure, a force of 200 N shall be applied directly to the test specimen and at a point to increase any aperture and therefore increase the possibility that the gap gauge can pass through.

NOTE A hand-held force gauge has been successfully used for this procedure.

At rest, the impactor shall be positioned $10 \text{ mm} \pm 5 \text{ mm}$ from the face of the test specimen.

7 Expression of results

The product shall be deemed to have failed if the gap gauge C can pass through an aperture in the product. Moving direction of the gauge (C) shall be perpendicular to the largest cross section of the gauge.

prEN 1629:2019 (E)**8 Test report**

The test report shall include the following details:

- a) name and address of the person or body carrying out the testing;
- b) name of the applicant, plus the name of the manufacturer of the test specimen, if different;
- c) details of the test specimen, to include:
 - 1) types of construction;
 - 2) profile references (codes, names, dimensions etc.);
 - 3) types of materials used;
 - 4) thickness of infilling and glazing;
- d) designation of materials;
- e) date of manufacture;
- f) declared classification of glazing used in the test specimen according to Table 1 of this standard;
- g) declared classification of applicable hardware standards or the result of additional tests if relevant (see prEN 1627:2019, Clause 6);
- h) attack side(s) of the test specimen;
- i) locking conditions effected during the test;
- j) drop height of the pendulum impactor, expressed in millimetres, the mass of the pendulum impactor, expressed in kilograms and tool set used;
- k) dimensioned drawings of the specimen, to include the following, which shall be inspected and stamped by the testing laboratory and retained by the applicant;
 - 1) dimensions and tolerances;
 - 2) list of the various parts of the construction product, including precise manufacturer's designation;
- l) installation instructions of the product (see Annex A of prEN 1627:2019);
- m) all relevant test results;
- n) range of manufacturing sizes;
- o) report of the condition of the specimen before the test including detailed description of any damage caused during the test;
- p) date of report;
- q) signature of responsible person.

STANDARD PREVIEW
(standards.iteh.ai)

oSIST prEN 1629:2019

for publication in the test log/standards/sist/8562e1d1-9a86-4944-9ab4-1b38ed34eee9/osist-pren-1629-2019

Annex A (informative)

Test equipment and impact points

A.1 Example of a test rig

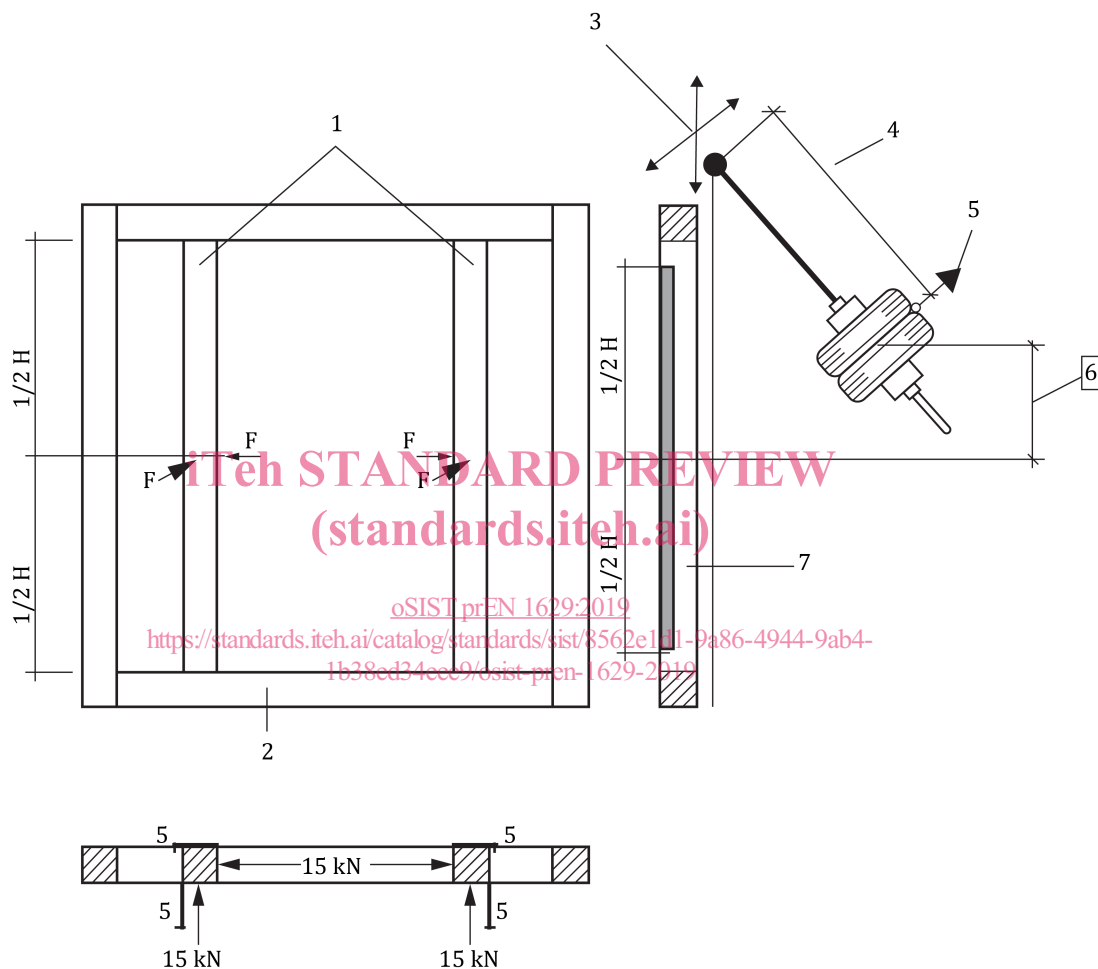

Key

- | | |
|---------------------------|--|
| 1 adjustable support | 4 length of the pendulum min. 1 000 mm |
| 2 main frame | 5 release hook |
| 3 complete impacting unit | 6 drop height |
| | 7 test specimen |

The complete impacting unit shall be adjustable.

The impacting unit may be installed on the test rig or as an independent unit.

Figure A.1 — Example of a test rig