



Standard Test Method for Cigarette Ignition Resistance of Mock-Up Upholstered Furniture Assemblies¹

This standard is issued under the fixed designation E 1352; the number immediately following the designation indicates the year of original adoption or, in the case of revision, the year of last revision. A number in parentheses indicates the year of last reapproval. A superscript epsilon (ϵ) indicates an editorial change since the last revision or reapproval.

1. Scope

1.1 This is a fire-test-response standard.

1.2 This test method is designed for the assessment of the resistance of upholstered furniture mock-up assemblies to combustion after exposure to smoldering cigarettes under specified conditions.

1.3 Mock-up testing is useful in assessing the relative resistance of combustion of materials used in upholstered furniture such as cover materials, cushioning materials, welts, etc., in representative combinations disregarding the geometric arrangement of the seating surfaces, backs, and sides of furniture items.

~~1.4 The values stated in inch-pound units are to be regarded as the standard. The values given in parentheses are for information only.~~

~~1.4 The values stated in inch-pound units are to be regarded as standard. The values given in parentheses are mathematical conversions to SI units that are provided for information only and are not considered standard.~~

1.5 *This standard is used to measure and describe the response of materials, products, or assemblies to heat and flame under controlled conditions, but does not by itself incorporate all factors required for fire hazard or fire risk assessment of the materials, products, or assemblies under actual fire conditions.*

1.6 *This standard does not purport to address all of the safety concerns, if any, associated with its use. It is the responsibility of the user of this standard to establish appropriate safety and health practices and determine the applicability of regulatory limitations prior to use. For specific hazard statements, see Section 7.*

2. Referenced Documents

2.1 *ASTM Standards:*²

E 176 Terminology of Fire Standards

E 691 Practice for Conducting an Interlaboratory Study to Determine the Precision of a Test Method

2.2 *NFPA Standard:*³

NFPA 261 Standard Method of Test for Determining Resistance of Mock-up Upholstered Furniture Material Assemblies to Ignition by Smoldering Cigarettes

3. Terminology

3.1 Definitions—For definitions of terms used in this test method, refer to Terminology E 176.

3.2 *Definitions of Terms Specific to This Standard:*

3.2.1 *bolster*—pillow or similarly shaped unit containing upholstery material covered by upholstery cover material that may or may not be attached to the upholstered furniture item but is sold and delivered with it.

3.2.2 *deck*—the upholstered support under the seat cushion in a loose-seat construction.

3.2.3 *furniture mock-up or assembly*—a representation of production furniture that uses the same upholstery cover material and upholstery material, constructed in the same manner as in production furniture, but with straight, vertical sides.

3.2.4 *quilted*—fused or stitched with thread through the upholstery cover material and one or more layers of upholstery material.

3.2.5 *tufted*—buttoned or laced through the upholstery cover material and upholstery material.

3.2.6 *upholstered furniture*—*for the purpose of this test method*, a unit of interior furnishing that (1) contains any surface that is covered, in whole or in part, with a fabric or related upholstery cover material, (2) contains upholstery material, and (3) is

¹ This test method is under the jurisdiction of ASTM Committee E05 on Fire Standards and is the direct responsibility of Subcommittee E05.15 on Furnishings and Contents.

Current edition approved Feb. 15, April 1, 2008. Published March/April 2008. Originally approved in 1990. Last previous edition approved in 2002 as E 1352 – 028.

² For referenced ASTM standards, visit the ASTM website, www.astm.org, or contact ASTM Customer Service at service@astm.org. For *Annual Book of ASTM Standards* volume information, refer to the standard's Document Summary page on the ASTM website.

³ A research report is available from ASTM International headquarters. Request RR:E01-1009.

³ Available from National Fire Protection Association (NFPA), 1 Batterymarch Park, Quincy, MA 02169-7471, <http://www.nfpa.org>.

intended or promoted for sitting or reclining upon.

3.2.7 *upholstery cover material*—the outermost layer of fabric or related material used to enclose the main support system or upholstery materials, or both, used in the furniture item.

3.2.8 *upholstery material*—the padding, stuffing, or filling material used in a furniture item, which may be either loose or attached, enclosed by an upholstery cover material, or located between the upholstery cover material and support system, if present.

3.2.8.1 *Discussion*—This includes, but is not limited to, material such as foams, cotton batting, polyester fiberfill, bonded cellulose, or down.

3.2.9 *welt*—the piping effect produced when welt cord and cover fabrics are sewn together for ornamental purposes to finish the edges between intersecting surfaces of upholstered furniture cushions, pillows, arms, or backs.

3.2.10 *welt cord*—the continuous small-diameter cylindrical material that is wrapped in fabric and sewn as part of the cover to make a welt edge on upholstered furniture.

4. Summary of Test Method

4.1 This test method is used to evaluate the cigarette ignition resistance of upholstered furniture by exposing mock-up upholstered furniture assemblies to lighted cigarettes as an ignition source.

5. Significance and Use

5.1 This test method is intended to measure the performance of upholstered furniture material assemblies under conditions of exposure to smoldering cigarettes. This is accomplished by testing furniture assemblies.

5.2 This test method is recommended for upholstered furniture used in facilities such as hospitals, nursing homes, residential-custodial care and supervisory facilities, or in the public area of facilities such as educational, assembly, or residential occupancies.

5.3 This test method is not intended to measure the performance of upholstered furniture material assemblies under conditions of open-flame exposure, and does not indicate whether the assemblies will resist the propagation of flame under severe fire exposure or when tested in a manner that differs substantially from the test method.

5.4 The results obtained with a material assembly tested in mock-up in accordance with this test method do not necessarily indicate the performance of the same material assembly in other geometric configurations, such as in production furniture.

6. Apparatus and Materials

6.1 *Mock-up*—Elements of the mock-up test jigs are illustrated in Figs. 1 and 2. Fig. 3 shows the completed mock-up assemblies.

6.2 *Ignition Source*, consisting of cigarettes without filter tips, made from natural tobacco 3.4 ± 0.1 in. (85 ± 2 mm) long with a packing density of 0.156 ± 0.012 oz/in.³ (0.270 ± 0.020 g/cm³) and a total weight of 0.039 ± 0.004 oz (1.1 ± 0.1 g). The smoldering rate of this cigarette shall be 0.236 ± 0.024 in./min (0.10 ± 0.01 mm/s) when the cigarette is allowed to burn downward in a draft-protected area.

NOTE 1—With the cigarette supported at the bottom in a vertical position, the burning rate is determined in the region from 0.39 to 1.97 in. (10 to 50 mm), measured from the top.

6.3 *Sheeting Material*—The sheeting material to cover the test cigarettes shall be 50 % cotton/50 % polyester or 100 % cotton bed sheeting material weighing 3.7 ± 0.8 oz/yd² (125 ± 28 g/m²). The material shall be laundered in an automatic home clothes washing machine and dried in a tumble drier at least once before use. For testing, the sheeting material shall be cut into pieces approximately 5 by 5 in. (12.5 by 12.5 cm).

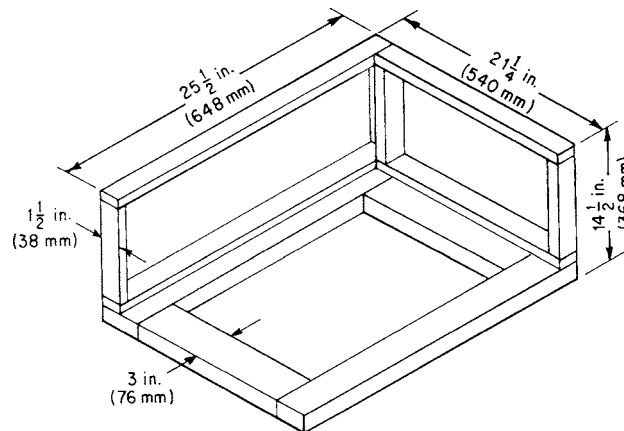

Material: Nominal 1 in. Frame Stock

FIG. 1 Frame for Upholstered Furniture Mock-Up Test

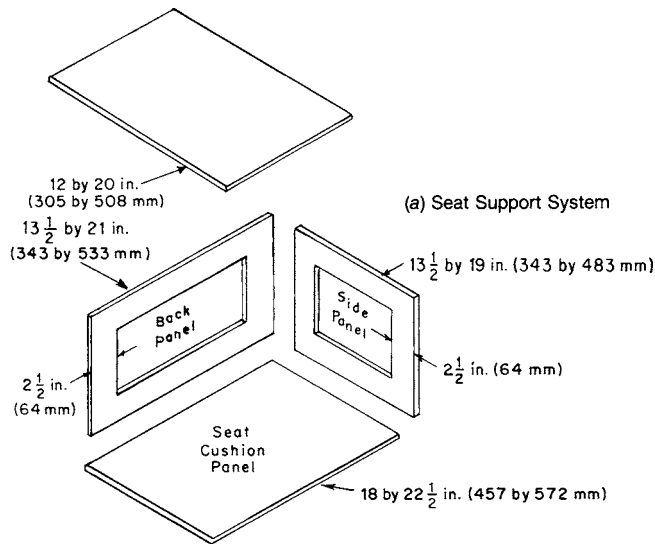

Material: Nominal 1/2 in.-thick Plywood

(b) Panel for Seat Cushion, Side, and Back

FIG. 2 Panels for Upholstered Furniture Mock-Up Test

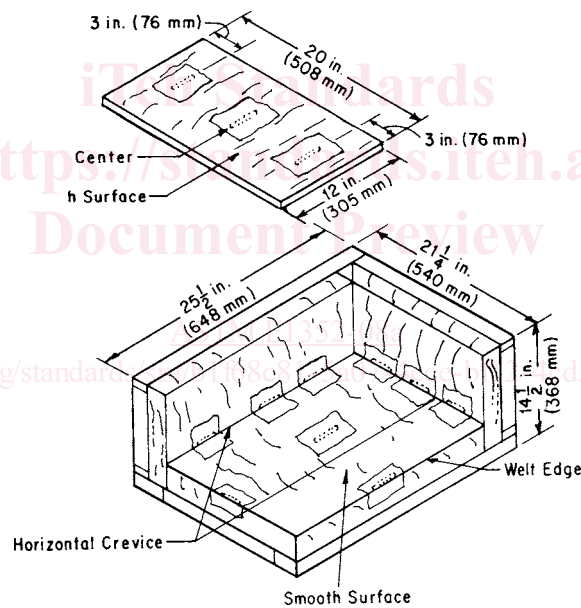

FIG. 3 Upholstered Furniture Mock-Up Test

6.4 *Test Area*, equipped with a suitable system for exhausting smoke and noxious gases produced during testing. The test shall be carried out in a draft protected area. The maximum airflow across the sample face shall be less than 50 ft (15.2 m)/min.

6.5 *Extinguishing Equipment*:

6.5.1 *Pressurized-Water Fire Extinguisher*, or other suitable fire-extinguishing equipment, immediately available.

6.5.2 *Water Botte*, fitted with a spray nozzle to extinguish any ignited portions of the mock-up.

6.5.3 *Bucket of Water*, for immersing smoldering or burning materials removed from the mock-up.

6.5.4 *Tongs*, to handle smoldering materials prior to immersion.

6.5.5 *Gloves*.

6.5.6 *Breathing Apparatus*.

6.6 *Miscellaneous*— Other apparatus required to carry out the testing are:

6.6.1 *Straight Pins*.

6.6.2 *Knife or Scissors*.

6.6.3 *Linear Scale*, at least 6 in. (15 cm) long and graduated in inches or millimeters in 1/10 or 1/16-in. divisions.

7. Hazards

7.1 **Warning**—Even under the most carefully observed conditions, smoldering combustion can progress to a point where it cannot be readily extinguished. It is imperative that a test be discontinued as soon as continuing combustion has definitely occurred. Immediately wet the exposed area with a water spray from the water bottle, remove the charred or burned material, and immerse the material in a bucket of water. Ventilate the test area.

7.2 Products of combustion can be irritating and dangerous to test personnel. Test personnel must avoid exposure to smoke and gases produced during testing as much as possible. The use of a large hood with a low air velocity during testing is advisable, as a means to remove products of combustion.

8. Test Specimen

8.1 *Specimen Conditioning*—Condition test samples, cigarettes, and sheeting material at a temperature of $73.4 \pm 9^\circ\text{F}$ ($23 \pm 5^\circ\text{C}$) and a relative humidity of $50 \pm 5\%$ for at least 24 h immediately prior to testing. If the test room conditions do not meet the above specifications, then testing shall be initiated within 10 min after the materials are removed from the conditioned room. The mock-up assembly shall be constructed in the conditioned area.

8.2 *General*—Produce furniture mock-up by arranging upholstery cover material and upholstery materials in the same sequence as they were used in the production furniture. Construct the various parts of the mock-up as described in 8.2-8.7. In all cases, the arrangement and thickness of upholstery material in the mock-up shall reproduce the construction details of the production furniture being evaluated.

8.3 *Loose Seat Cushions*—Make seat cushions in the same size and manner and with the same material as production furniture. The cushion thickness shall be a maximum of 5 in. (13 cm).

8.3.1 *Exception*—Use cushions sized 25 by 22 in. (68 by 55 cm) if actual cushion dimensions exceed these values.

8.4 *Decks*—Prepare decks (if they are part of the furniture item) by attaching to the horizontal panel (Fig. 2(a)) of the test apparatus the same materials in the same thickness as used in the actual furniture construction. Stretch decking or upholstery cover material over the upholstery materials and securely fasten to the underside of the wood panel.

8.5 *Tight Seat*—If the type of furniture item is constructed with only tight seats, duplicate the seat for test in mock-up. Tight seat cushions shall be 18 ± 2 by 22 ± 2 in. (45 ± 5 by 55 ± 5 cm) and made of the same fabric and the same thickness used in production furniture. Attach the cushion assembly to the horizontal panel of the test apparatus (see Fig. 2(b)) by extending the upholstery cover material around the panel edges and fastening the cover material to the underside of the wood panel.

8.6 *Side and Back Panels*—Furniture sides and backs shall be mocked-up if, in the type of furniture to be represented by the mock-up, they are within 1 in. (2.5 cm) of a seat cushion. Make the mock-ups by upholstering one surface of the vertical test panel (see Fig. 2(b)) with the same upholstery material and upholstery cover material used in production furniture. Stretch the upholstery cover material over the upholstery material and fasten to the back side of the framework. Cover all edges of the panels with cover material. If the side and back construction of the furniture item are the same, only one vertical panel need be assembled and tested.

8.7 *Bolsters*—Bolsters resting on the seat cushion or suspended above it tend to confine the heat from the cigarette and often present a spatial arrangement different from the crevice. In such cases, prepare a mock-up bolster with dimensions to fit into the mock-up arrangement and which presents to the cigarette the same spatial arrangement as in production furniture.

8.8 *Armrests and Tops of Backs*—Test tops of armrests and back if (1) they present a surface large enough and so oriented as to support a cigarette and (2) if the construction differs in any way from the side-panel and back-panel constructions. Make tops of armrests and backs by upholstering a piece of 0.5-in. (1.3-cm) thick plywood, approximately 12 by 20 in. (30 by 50 cm) with the same materials used in the furniture item. The mock-up shall reproduce significant details of the construction of production furniture.

9. Procedure

9.1 Assemble a mock-up test sample by attaching the side or back panels, or both, to the mock-up frame and placing a seat cushion (either loose or tight seat construction) against the panels, as shown in Fig. 3(b). Place the assembly on a table or platform in the test area under an exhaust hood or other suitable means for exhausting the products of combustion from testing. Test separately the decks for loose cushion items, top of armrests, and backs. In some cases, the test to evaluate upholstered furniture material assemblies for cigarette ignition resistance will require two vertical panels, one seat cushion (loose or tight), one bolster, one deck, one top of armrest, and one top of back.

9.2 Burn at least three cigarettes on each surface location (see Fig. 3(a) and (b)). These locations include crevice(s) where seat cushion and vertical panels meet, seat cushion surfaces (including welt and smooth, quilted or tufted areas), top of upholstered arm rest, tops of upholstered back, and deck.

9.3 For crevice locations, place the two cigarettes next to the center cigarette in the crevice so that their butt ends burn out at least 3 in. (7.5 cm) from the outermost edge of the side of the back panel. Place the cigarettes horizontally. Place two of the three cigarettes so that their entire length burns out against the welt cord and the vertical panel surface. Place the third cigarette so that its entire length burns out against the welt cord and a horizontal surface of the seat cushion.

9.4 Each test cigarette shall be well-lighted and burned not more than 0.16 in. (4 mm) when placed on a specific test location. After placement, cover each cigarette with a piece of sheeting material. For crevice tests, pin one end of the sheeting material to the vertical panels (approximately 2 in. (5 cm) above the cigarette) and drop the remaining material to completely cover the test

cigarette. For all tests, ensure that a good sheeting material-to-cigarette contact is made by running one's finger across the full length of the covered cigarette.

9.5 To test a seat cushion (either loose or tight), burn three covered cigarettes on each different surface location encountered.

9.5.1 For the purposes of this test, consider smooth surfaces, welt edges, fused or threaded portions of quilts, and tuft depressions as different surface locations on a seat cushion. Arrange test cigarettes so that the butt ends burn out on the threads of a quilt or in tuft depressions. The smooth surface of a quilted or tufted cushion is not required to be tested. For smooth surface cushions, burn the test cigarettes in the center of the cushion.

9.6 Burn three test cigarettes on each horizontal mock-up test panel duplicating armrests, tops of backs, and seat cushion support systems. Burn one cigarette at the center of the panel and the other two at least 3 in. (7.5 cm) from the edges of the test panel. See Fig. 3(a) for the location of the cigarettes on the test panels.

9.7 A test on any location is considered complete when any of the following occurs:

9.7.1 Three cigarettes in a given location have burned their full lengths without sustained ignition,

9.7.2 Three cigarettes in a given location have extinguished before burning their full lengths, or

9.7.3 Three cigarettes in a given location sustained ignition.

9.8 If continuing ignition occurs (that is, fabric and filling materials are ignited and are smoldering and generating smoke at a rapid rate), there is no need to wait until a cigarette has burned its full length; stop the test and extinguish the burning material. Ventilate the test room and record an ignition for the cigarette test location.

9.9 *Char Length Measurement:*

9.9.1 If the cigarette burns to completion in a test location, measure the maximum char length in any direction of any material from the nearest point of the original location of the cigarette.

9.9.2 Record the char length measurement for each cigarette, except when the cigarette has extinguished without burning to completion or where continuing combustion occurs. If the char from one cigarette runs into that from another, the results of the test are invalid and the test shall be repeated running one cigarette at a time. Disassemble all mock-ups.

9.9.3 If, when disassembling the apparatus, it is shown that smoldering is still in progress, then the test is invalid and must be repeated.

10. Report

10.1 Record the maximum char distance, measured to the nearest 0.1 in. (0.2 cm) from the nearest point of the original location of the test cigarette, for each cigarette location, except when a continuing combustion occurs. In this case, record an ignition for the test location. Measurements exceeding 2 in. (5.1 cm) shall be reported as follows: >2 in.

11. Precision and Bias ⁴

11.1 *Precision:*

11.1.1 An interlaboratory evaluation was performed to provide an estimate of the precision of the test method, wherein 5 laboratories tested 12 systems, each with 8 different fabrics. The individual fabrics in each class are identified as Sample 1 through 8 on Tables 1-5. The systems tested, in triplicate, are as shown in 11.1.1.1-11.1.1.12.

11.1.1.1 Fabric class fiberglass.

11.1.1.2 Fabric class untreated cotton.

11.1.1.3 Cover fabric FR cotton.

11.1.1.4 Back seat FR cotton.

11.1.1.5 Back seat foam.

11.1.1.6 Back seat PE/FR cotton.

11.1.1.7 Side seat FR cotton.

11.1.1.8 Side seat foam.

11.1.1.9 Side seat 1 in. PE/FR cotton.

11.1.1.10 Cushion foam.

11.1.1.11 Cushion FR cotton.

11.1.1.12 Cushion 1 in. PE/FR cotton.

11.1.2 The statistical analyses for repeatability and reproducibility were conducted in two ways: based on actual measurements of char length (as the standard requires; see 11.1.3) and based on pass/fail (see 11.1.4). This test, in practical use, is a pass/fail test.

11.1.3 The results of the statistical analysis for repeatability and reproducibility of the individual systems in the interlaboratory study, determined in accordance with Practice E 691 (although the number of laboratories is lower than recommended by Practice E 691), are shown in Tables 1 and 2. This is the analysis involving actual numerical results. Results of over 2 in. were not reported by the laboratories. Therefore, any result greater than 2 in. was considered to be 2 in., because testing was discontinued at this

⁴ For additional information, see Ohlemiller, T.J., Villa, K.M., Braun, E., Eberhardt, K.R., Harris, R.H., Lawson, J.R., and Gann, R.G., "Test Methods for Quantifying the Propensity of Cigarettes to Ignite Soft Furnishings," *NIST Special Publication 851*, National Institute of Standards Technology, Gaithersburg, MD, 1993.

⁴ A research report is available from ASTM International headquarters. Request RR:E01-1009.

TABLE 1 Interlaboratory Study for ASTM E 1352 (Results in in.)

Class of Test	Material	Average	STD Repeat	STD Repro	r	R
Fabric Class Fiberglass	Sample 1	0.647	0.089	0.136	0.25	0.38
	Sample 2	1.927	0.128	0.195	0.36	0.54
	Sample 3	0.573	0.070	0.106	0.20	0.30
	Sample 4	0.620	0.056	0.083	0.16	0.23
	Sample 5	1.800	0.256	0.352	0.72	0.98
	Sample 6	1.053	0.277	0.608	0.78	1.70
	Sample 7	0.753	0.191	0.259	0.53	0.72
	Sample 8	0.567	0.037	0.061	0.10	0.17
Fabric Class Untreated Cotton	Sample 1	1.100	0.278	0.700	0.78	1.96
	Sample 2	1.467	0.299	0.563	0.84	1.58
	Sample 3	0.493	0.060	0.137	0.17	0.38
	Sample 4	0.793	0.174	0.551	0.49	1.54
	Sample 5	1.660	0.393	0.565	1.10	1.58
	Sample 6	1.440	0.405	0.614	1.13	1.72
	Sample 7	1.680	0.280	0.558	0.78	1.56
	Sample 8	1.180	0.411	0.687	1.15	1.92
Cover Fabric FR Cotton	Sample 1	0.853	0.303	0.310	0.85	0.87
	Sample 2	1.087	0.224	0.534	0.63	1.50
	Sample 3	0.573	0.042	0.152	0.12	0.43
	Sample 4	0.693	0.084	0.141	0.24	0.40
	Sample 5	1.273	0.280	0.740	0.79	2.07
	Sample 6	0.900	0.420	0.512	1.18	1.43
	Sample 7	1.133	0.307	0.498	0.86	1.39
	Sample 8	0.733	0.084	0.124	0.24	0.35
Back Seat FR Cotton	Sample 1	0.467	0.060	0.170	0.17	0.48
	Sample 2	0.567	0.037	0.246	0.10	0.69
	Sample 3	0.493	0.047	0.156	0.13	0.44
	Sample 4	0.520	0.063	0.172	0.18	0.48
	Sample 5	0.607	0.149	0.452	0.42	1.27
	Sample 6	0.533	0.073	0.324	0.20	0.91
	Sample 7	0.533	0.056	0.237	0.16	0.66
	Sample 8	0.407	0.089	0.162	0.25	0.45
Back Seat Foam	Sample 1	0.547	0.079	0.181	0.22	0.51
	Sample 2	1.920	0.253	0.273	0.71	0.77
	Sample 3	0.487	0.047	0.228	0.13	0.64
	Sample 4	0.573	0.070	0.162	0.20	0.45
	Sample 5	1.713	0.042	0.642	0.12	1.80
	Sample 6	0.700	0.101	0.345	0.28	0.97
	Sample 7	1.133	0.335	0.601	0.94	1.68
	Sample 8	0.620	0.076	0.228	0.21	0.64
Back Seat PE/FR Cotton	Sample 1	0.413	0.042	0.124	0.12	0.35
	Sample 2	0.607	0.267	0.413	0.75	1.16
	Sample 3	0.600	0.052	0.187	0.14	0.52
	Sample 4	0.533	0.070	0.212	0.20	0.59
	Sample 5	0.573	0.042	0.223	0.12	0.62
	Sample 6	0.580	0.067	0.257	0.19	0.72
	Sample 7	0.527	0.052	0.226	0.14	0.63
	Sample 8	0.500	0.047	0.159	0.13	0.45

point, the maximum char length usually permitted by users. The precision calculated by assuming that the maximum char length measurement is 2.0 in. does not address the precision of the measurement over the entire possible range, but includes all values up to the point of failure, which are the measurements of concern. Figs. 4 and 5 present the plot of reproducibility vs. repeatability and reproducibility variance vs. repeatability variance, for this analysis, respectively, as part of the information derived from Practice E 691. The abbreviations used are: STD Repeat: standard deviation of the repeatability; STD Repro: standard deviation of the reproducibility; r: system repeatability; and R: system reproducibility.

11.1.4 The results of the statistical analysis for repeatability and reproducibility of the individual systems, for the interlaboratory study, with the data analyzed as if they produce pass/fail results (fail was taken to be a value of over 2.0 in.) are shown in Tables 3 and 4. Test results greater than 2.0 in. were assigned a “Fail” value of 0 and test results less than 2.0 were assigned a “Pass” value of 1. This analysis was conducted assuming that there can be two possible outcomes: Pass or Fail. Figs. 6 and 7 present the