



SLOVENSKI STANDARD

SIST EN 13451-10:2018

01-december-2018

Nadomešča:

SIST EN 13451-10:2014

Oprema za plavalne bazene - 10. del: Dodatne posebne varnostne zahteve in preskusne metode za odskočne ploščadi, odskočne deske in pripadajočo opremo

Swimming pool equipment - Part 10: Additional specific safety requirements and test methods for diving platforms, diving springboards and associated equipment

Schwimmbadgeräte - Teil 10: Zusätzliche besondere sicherheitstechnische Anforderungen und Prüfverfahren für Sprungplattformen, Sprungbretter und zugehörige Geräte

Équipement de piscine - Partie 10: Exigences de sécurité et méthodes d'essai complémentaires propres aux plates-formes de plongeon, aux plongeurs et à l'équipement associé

Ta slovenski standard je istoveten z: EN 13451-10:2018

ICS:

97.220.10 Športni objekti Sports facilities

SIST EN 13451-10:2018 en,fr,de

iTeh STANDARD PREVIEW
(standards.iteh.ai)

[SIST EN 13451-10:2018](#)

<https://standards.iteh.ai/catalog/standards/sist/5bc64b96-732a-4c9b-ac45-6e126c197d6a/sist-en-13451-10-2018>

EUROPEAN STANDARD

EN 13451-10

NORME EUROPÉENNE

EUROPÄISCHE NORM

August 2018

ICS 97.220.10

Supersedes EN 13451-10:2014

English Version

Swimming pool equipment - Part 10: Additional specific safety requirements and test methods for diving platforms, diving springboards and associated equipment

Équipement de piscine - Partie 10 : Exigences de sécurité et méthodes d'essai complémentaires propres aux plates-formes de plongeon, aux plongeoirs et à l'équipement associé

Schwimmbadgeräte - Teil 10: Zusätzliche besondere sicherheitstechnische Anforderungen und Prüfverfahren für Sprungplattformen, Sprungbretter und zugehörige Geräte

This European Standard was approved by CEN on 6 May 2018.

CEN members are bound to comply with the CEN/CENELEC Internal Regulations which stipulate the conditions for giving this European Standard the status of a national standard without any alteration. Up-to-date lists and bibliographical references concerning such national standards may be obtained on application to the CEN-CENELEC Management Centre or to any CEN member.

This European Standard exists in three official versions (English, French, German). A version in any other language made by translation under the responsibility of a CEN member into its own language and notified to the CEN-CENELEC Management Centre has the same status as the official versions.

CEN members are the national standards bodies of Austria, Belgium, Bulgaria, Croatia, Cyprus, Czech Republic, Denmark, Estonia, Finland, Former Yugoslav Republic of Macedonia, France, Germany, Greece, Hungary, Iceland, Ireland, Italy, Latvia, Lithuania, Luxembourg, Malta, Netherlands, Norway, Poland, Portugal, Romania, Serbia, Slovakia, Slovenia, Spain, Sweden, Switzerland, Turkey and United Kingdom.



EUROPEAN COMMITTEE FOR STANDARDIZATION
COMITÉ EUROPÉEN DE NORMALISATION
EUROPÄISCHES KOMITEE FÜR NORMUNG

CEN-CENELEC Management Centre: Rue de la Science 23, B-1040 Brussels

Contents	Page
European foreword.....	3
Introduction	4
1 Scope	5
2 Normative references	5
3 Terms and definitions	5
4 Safety requirements	6
4.1 Tolerances	6
4.2 Diving platforms.....	6
4.3 Diving springboards.....	12
4.4 Means of access	17
4.5 Safety barriers.....	18
4.6 Slip resistance	19
4.7 Water diving zones	20
4.8 Agitation of water surface.....	20
4.9 Air cushion equipment.....	20
5 Test methods	21
5.1 General.....	21
5.2 Structural integrity of diving springboards.....	21
5.3 Structural integrity of stepladders.....	22
5.4 Structural integrity of safety barriers.....	23
Annex A (informative) A-deviations	24
Bibliography	26

European foreword

This document (EN 13451-10:2018) has been prepared by Technical Committee CEN/TC 136 “Sports, playground and other recreational facilities and equipment”, the secretariat of which is held by DIN.

This European Standard shall be given the status of a national standard, either by publication of an identical text or by endorsement, at the latest by February 2019, and conflicting national standards shall be withdrawn at the latest by February 2019.

Attention is drawn to the possibility that some of the elements of this document may be the subject of patent rights. CEN shall not be held responsible for identifying any or all such patent rights.

This document supersedes EN 13451-10:2014.

In relation to EN 13451-10 the following main amendments have been made:

- a) the values in Tables 2 and 4 have been compared with and where required revised according to the values of the current FINA Table;
- b) clause on stepladders for diving facilities revised (4.4.2);
- c) clause on safety barriers revised (4.5);
- d) clause on slip resistance revised (4.6);
- e) Adding informative Annex A-Deviation from Estonia.

This document includes an A-Deviation from Estonia.

The EN 13451 series, *Swimming pool equipment* consists of the following parts:

- Part 1: *General safety requirements and test methods*
- Part 2: *Additional specific safety requirements and test methods for ladders, stepladders and handle bends*
- Part 3: *Additional specific safety requirements and test methods for inlets and outlets and water/air based water leisure features*
- Part 4: *Additional specific safety requirements and test methods for starting platforms*
- Part 5: *Additional specific safety requirements and test methods for lane lines and dividing line*
- Part 6: *Additional specific safety requirements and test methods for turning boards*
- Part 7: *Additional specific safety requirements and test methods for water polo goals*
- Part 10: *Additional specific safety requirements and test methods for diving platforms, diving springboards and associated equipment*
- Part 11: *Additional specific safety requirements and test methods for moveable pool floors and moveable bulkheads*

According to the CEN-CENELEC Internal Regulations, the national standards organisations of the following countries are bound to implement this European Standard: Austria, Belgium, Bulgaria, Croatia, Cyprus, Czech Republic, Denmark, Estonia, Finland, Former Yugoslav Republic of Macedonia, France, Germany, Greece, Hungary, Iceland, Ireland, Italy, Latvia, Lithuania, Luxembourg, Malta, Netherlands, Norway, Poland, Portugal, Romania, Serbia, Slovakia, Slovenia, Spain, Sweden, Switzerland, Turkey and the United Kingdom.

Introduction

Diving is a voluntary movement into water with arms and head entering the water first or a voluntary movement into water with feet entering the water first while performing acrobatics.

There can be additional requirements for purposes such as competition swimming, and advice should be sought from the governing body of the sport in question (see [1] and [2]).

iTeh STANDARD PREVIEW (standards.iteh.ai)

[SIST EN 13451-10:2018](https://standards.iteh.ai/catalog/standards/sist/5bc64b96-732a-4c9b-ac45-6e126c197d6a/sist-en-13451-10-2018)

<https://standards.iteh.ai/catalog/standards/sist/5bc64b96-732a-4c9b-ac45-6e126c197d6a/sist-en-13451-10-2018>

1 Scope

This part of the EN 13451 series specifies safety requirements for diving platforms, diving springboards and associated equipment in addition to the general safety requirements of EN 13451-1 and is meant to be read in conjunction with it.

The requirements of this part of the EN 13451 series take priority over those in EN 13451-1.

This part of the EN 13451 series is applicable to platforms and springboards, and associated equipment for use in classified swimming pools as specified in EN 15288-1 and EN 15288-2.

2 Normative references

The following documents are referred to in the text in such a way that some or all of their content constitutes requirements of this document. For dated references, only the edition cited applies. For undated references, the latest edition of the referenced document (including any amendments) applies.

EN 13451-1:2011+A1:2016, *Swimming pool equipment — Part 1: General safety requirements and test methods*

EN 13451-3, *Swimming pool equipment — Part 3: Additional specific safety requirements and test methods for inlets and outlets and water/air based water leisure features*

EN 22768-1, *General tolerances — Part 1: Tolerances for linear and angular dimensions without individual tolerance indications (ISO 2768-1)*

3 Terms and definitions

<https://standards.iteh.ai/catalog/standards/sist/5bc64b96-732a-4c9b-ac45-6e126c197d6a/sist-en-13451-10-2018>

For the purposes of this document, the terms and definitions given in EN 13451-1:2011+A1:2016 and the following apply.

ISO and IEC maintain terminological databases for use in standardization at the following addresses:

- IEC Electropedia: available at <http://www.electropedia.org/>
- ISO Online browsing platform: available at <http://www.iso.org/obp>

3.1

diving facility

installation designed to provide the opportunity of diving

3.2

diving platform

raised rigid horizontal platform, protruding over the water, intended for diving

3.3

diving springboard type 1

raised flexible board, installed at a height $1,0\text{ m} \leq h \leq 3,05\text{ m}$ above water level and protruding over the water, intended for diving

3.4

diving springboard type 2

raised flexible board, which can be permanently installed or portable, with a height $< 1,0\text{ m}$ from water level and protruding over the water, intended for recreational diving

EN 13451-10:2018 (E)

3.5

plummet line

vertical line extending through the centre of the front edge of a platform or springboard

3.6

water agitation device

equipment designed to improve visibility of the water surface by disturbance

3.7

air cushion equipment

training device, designed for introducing air from the bottom of a diving pool, in front of a diving platform and/or springboard, to reduce the effects of the impact of the diver with the pool water and make training safer

4 Safety requirements

4.1 Tolerances

Tolerances of height of the diving platform and diving springboards are $^{+0,05}_0$ m.

For all other tolerances, if not indicated, EN 22768-1 applies.

4.2 Diving platforms

iTeh STANDARD PREVIEW
(standards.iteh.ai)

4.2.1 General

Particular attention shall be paid to avoid glare and reflecting surfaces, which can disturb the vision of the diver.

In Europe, outdoor diving facilities should face north.

4.2.2 Dimensions

The dimensions indicated in Figures 1 to 4 and Tables 1 to 2 shall be complied with. The design of the equipment does not need to comply with the examples given.

Platforms shall be horizontal.

The minimum dimensions of the platforms shall comply with Table 1.

Table 1 — Areas of use

Dimensions in metres

Height of platforms from water level	Minimum usable width	Length reserved for the diver ^a
1	0,60	0,75
3	0,60	1,25
5	1,50	1,25
7,5	1,50	1,50
10	3,00	1,50

^a Minimum distance back from plummet.

NOTE 1 In addition to the length reserved for the diver (minimum distance back from plummet), additional space can be necessary for other purposes, as wider range of dives (e.g. dives with preliminary run), space for waiting for the dive, space for divers passing to the next platform.

If synchronized diving (more than one diver starting at a same time from the platform) is foreseen, the width of the platforms should be suitably increased. As an alternative, during synchronized diving activities only there should be the possibility to increase temporarily the distance of the safety barriers for arm movement (see [1]).

The minimum dimensions of the platform facilities shall comply with Table 2 and with Figure 1.

Table 2 — Minimum dimensions of diving platform facilities

Dimensions in metres

Minimum height of platform from water level		1 m		3 m		5 m		7,5 m		10 m	
		horizontal	vertical	horizontal	vertical	horizontal	vertical	horizontal	vertical	horizontal	vertical
A	From plummet back to pool wall	0,75	—	1,25	—	1,25	—	1,25	—	1,50	—
A/A ^a	From plummet back to platform plummet vertically below	—	—	—	—	0,75	—	0,75	—	0,75	—
B ^b	From plummet to pool wall at side	2,30	—	2,80	—	3,25	—	4,25	—	5,25	—
C ^{b, c}	From plummet to adjacent plummet	1,65	—	2,00	—	2,25	—	2,50	—	2,75	—
D	From plummet to pool wall ahead	8,00	—	9,50	—	10,25	—	11,00	—	13,50	—
E	On plummet, from board to ceiling	3,25	—	3,25	—	3,25	—	3,25	—	4,00	—
F ^d	Distance behind and each side of plummet with height E	2,30	—	2,75	—	2,75	—	2,75	—	2,75	—
G	Distance ahead of plummet with height E	5,00	—	5,00	—	5,00	—	5,00	—	6,00	—
H	Depth of water at plummet	—	3,20	—	3,50	—	3,70	—	4,10	—	4,50
J	Distance ahead of plummet with a water depth K	4,50	—	5,50	—	6,00	—	8,00	—	11,00	—
K	minimum water depth between plummet and distance J	—	3,10	—	3,40	—	3,60	—	4,00	—	4,25
L	Distance on each side of plummet with a water depth M	1,40	—	1,80	—	3,00	—	3,75	—	4,50	—
M	minimum water depth between plummet and distance L	—	3,10	—	3,40	—	3,60	—	4,00	—	4,25

EN 13451-10:2018 (E)

- a on plummet, also from platform to the bottom side of a platform, if vertically above
- b Dimensions B and C apply to platforms with widths as in Table 1; if platform widths are increased then B, C, F and L shall be increased by half of the additional width(s).
- c The dimension C applies also to combinations of platform and spring board (e.g. 5 m platform combined with a 3 m spring board).
- d F is also valid for arm moves backwards, so for the 1 m platform $F = 2,75$ (backwards) applies.

The maximum slope of surfaces to reduce dimensions beyond full requirements shall be $\leq 30^\circ$ for ceilings and pool bottoms.

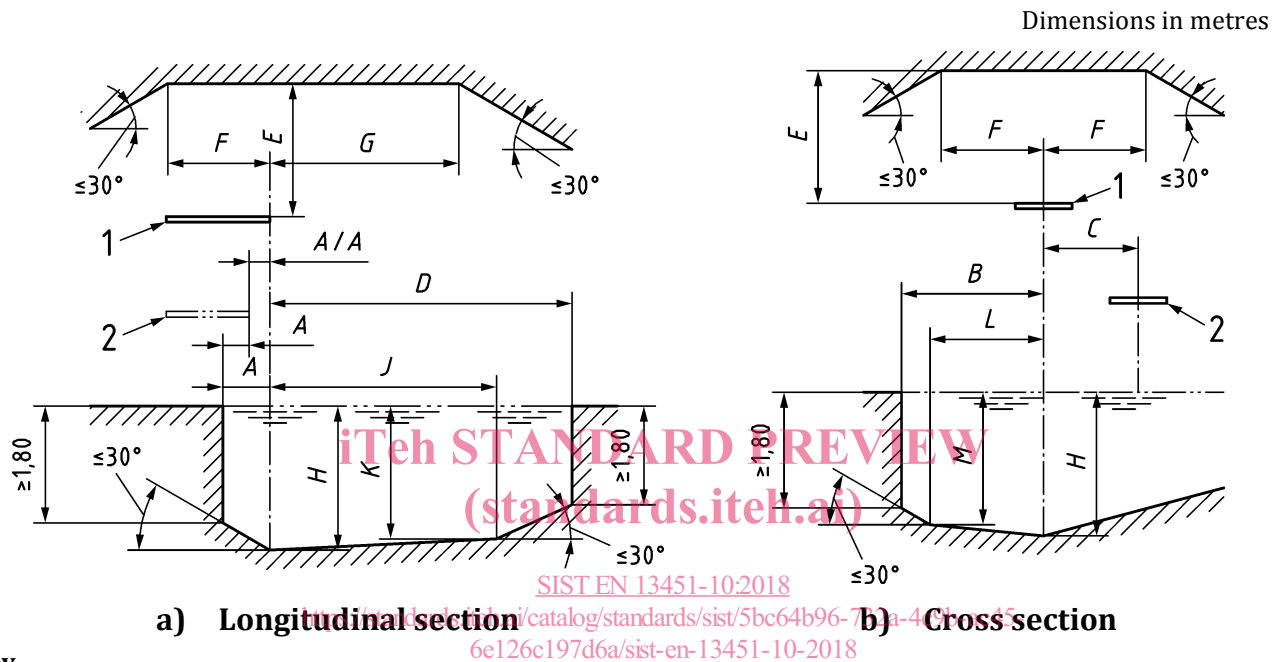
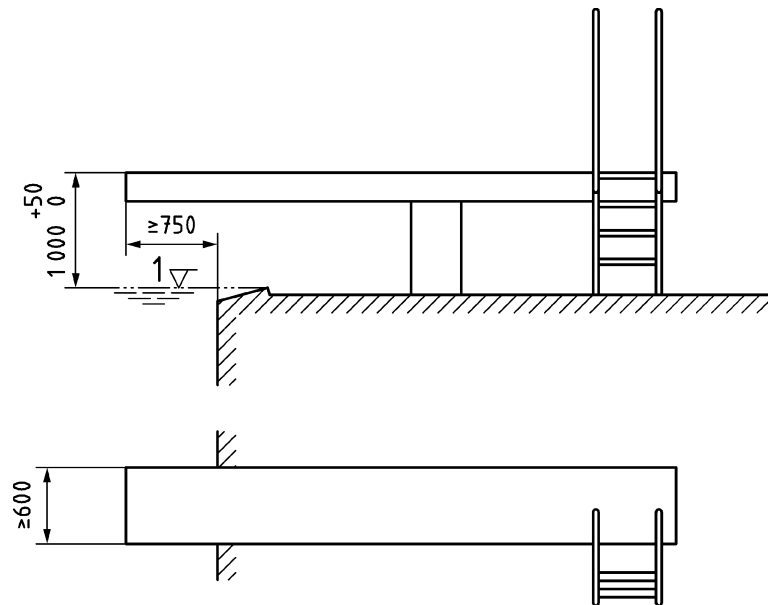

Figure 1 — Diagrammatic side and front view of diving platform facilities

Intermediate heights from water level are allowed, provided the user is made aware of the actual height and the safety requirements of the next higher facility are fulfilled.

The front edge of each platform shall be vertical, or inclined up to an angle $\leq 10^\circ$ to the vertical inside the plummet line. The thickness of the front edge shall be between 200 mm and 300 mm.

Dimensions in millimetres

**Key**

1 water level

iTeh STANDARD PREVIEW
Figure 2 — Diving platform (1 m high)
(standards.iteh.ai)SIST EN 13451-10:2018<https://standards.iteh.ai/catalog/standards/sist/5bc64b96-732a-4c9b-ac45-6e126c197d6a/sist-en-13451-10-2018>