**Solid biofuels — Determination of
mechanical durability of pellets and
briquettes —**

**Part 2:
Briquettes**

iTeh STANDARD PREVIEW
*Biocombustibles solides — Détermination de la résistance mécanique
des granulés et des briquettes —*
(standards.iteh.ai)
Partie 2: Briquettes

[ISO 17831-2:2015](https://standards.iteh.ai/catalog/standards/sist/823d71c3-c531-45e3-b10a-b8845681ba93/iso-17831-2-2015)

<https://standards.iteh.ai/catalog/standards/sist/823d71c3-c531-45e3-b10a-b8845681ba93/iso-17831-2-2015>



iTeh STANDARD PREVIEW
(standards.iteh.ai)

ISO 17831-2:2015

<https://standards.iteh.ai/catalog/standards/sist/823d71c3-c531-45e3-b10a-b8845681ba93/iso-17831-2-2015>



COPYRIGHT PROTECTED DOCUMENT

© ISO 2015, Published in Switzerland

All rights reserved. Unless otherwise specified, no part of this publication may be reproduced or utilized otherwise in any form or by any means, electronic or mechanical, including photocopying, or posting on the internet or an intranet, without prior written permission. Permission can be requested from either ISO at the address below or ISO's member body in the country of the requester.

ISO copyright office
Ch. de Blandonnet 8 • CP 401
CH-1214 Vernier, Geneva, Switzerland
Tel. +41 22 749 01 11
Fax +41 22 749 09 47
copyright@iso.org
www.iso.org

Contents

	Page
Foreword.....	iv
Introduction.....	v
1 Scope.....	1
2 Normative references.....	1
3 Terms and definitions.....	1
4 Principle.....	1
5 Apparatus.....	2
5.1 Briquette tester.....	2
5.2 Sieve.....	3
5.3 Balance.....	3
6 Test sample preparation.....	3
7 Procedure.....	4
7.1 Tumbling procedure.....	4
7.2 Sieving procedure.....	4
8 Calculation of the mechanical durability.....	5
9 Performance characteristics.....	5
10 Test report.....	5
Bibliography.....	6

<https://standards.iteh.ai/catalog/standards/sist/823d71c3-c531-45e3-b10a-b8845681ba93/iso-17831-2-2015>
 ISO 17831-2:2015
 (standards.iteh.ai)

Foreword

ISO (the International Organization for Standardization) is a worldwide federation of national standards bodies (ISO member bodies). The work of preparing International Standards is normally carried out through ISO technical committees. Each member body interested in a subject for which a technical committee has been established has the right to be represented on that committee. International organizations, governmental and non-governmental, in liaison with ISO, also take part in the work. ISO collaborates closely with the International Electrotechnical Commission (IEC) on all matters of electrotechnical standardization.

The procedures used to develop this document and those intended for its further maintenance are described in the ISO/IEC Directives, Part 1. In particular the different approval criteria needed for the different types of ISO documents should be noted. This document was drafted in accordance with the editorial rules of the ISO/IEC Directives, Part 2 (see www.iso.org/directives).

Attention is drawn to the possibility that some of the elements of this document may be the subject of patent rights. ISO shall not be held responsible for identifying any or all such patent rights. Details of any patent rights identified during the development of the document will be in the Introduction and/or on the ISO list of patent declarations received (see www.iso.org/patents).

Any trade name used in this document is information given for the convenience of users and does not constitute an endorsement.

For an explanation on the meaning of ISO specific terms and expressions related to conformity assessment, as well as information about ISO's adherence to the WTO principles in the Technical Barriers to Trade (TBT) see the following URL: [Foreword - Supplementary information](#)

The committee responsible for this document is ISO/TC 238, *Solid biofuels*.

ISO 17831 consists of the following parts under the general title *Solid Biofuels — Determination of mechanical durability of pellets and briquettes*:
<http://www.iso.org/standards/catalog/standards/sist/823d71c3-c531-45e3-b10a-b8845681ba93/iso-17831-2-2015>

- *Part 1: Pellets*
- *Part 2: Briquettes*

Introduction

Compressed solid biomass fuel is usually assigned to either pellets or briquettes, of which pellets usually have a diameter below 25 mm, while for briquettes, the diameter is higher (see ISO 17225-1). To account for the different particle dimensions, it was necessary to define different test apparatuses.

iTeh STANDARD PREVIEW (standards.iteh.ai)

[ISO 17831-2:2015](https://standards.iteh.ai/catalog/standards/sist/823d71c3-c531-45e3-b10a-b8845681ba93/iso-17831-2-2015)

<https://standards.iteh.ai/catalog/standards/sist/823d71c3-c531-45e3-b10a-b8845681ba93/iso-17831-2-2015>

iTeh STANDARD PREVIEW
(standards.iteh.ai)

ISO 17831-2:2015

<https://standards.iteh.ai/catalog/standards/sist/823d71c3-c531-45e3-b10a-b8845681ba93/iso-17831-2-2015>

Solid biofuels — Determination of mechanical durability of pellets and briquettes —

Part 2: Briquettes

1 Scope

This part of ISO 17831 defines a method for determining the mechanical durability of briquettes. The mechanical durability is a measure of the resistance of compressed fuels towards shocks and/or abrasion as a consequence of handling and transportation.

2 Normative references

The following documents, in whole or in part, are normatively referenced in this document and are indispensable for its application. For dated references, only the edition cited applies. For undated references, the latest edition of the referenced document (including any amendments) applies.

ISO 3310-1, *Test sieves — Technical requirements and testing — Part 1: Test sieves of metal wire cloth*

ISO 14780, *Solid biofuels — Sample preparation*¹⁾

ISO 16559, *Solid biofuels — Terminology, definitions and descriptions*

ISO 18134-1, *Solid biofuels — Determination of moisture content — Oven dry method — Part 1: Total moisture — Reference method*

ISO 18134-2, *Solid biofuels — Determination of moisture content — Oven dry method — Part 2: Total moisture — Simplified method*

ISO 18135, *Solid Biofuels — Sampling*¹⁾

3 Terms and definitions

For the purpose of this document, the terms and definitions given in ISO 16559 apply.

4 Principle

The test portion is subjected to controlled shocks by collision of briquettes against each other and against the walls of a specified rotating test chamber. The durability is calculated from the mass of the sample remaining after separation of abraded and fine broken particles.

1) In preparation.

5 Apparatus

5.1 Briquette tester

The briquette tester (durability drum) shall be a cylindrical steel drum with a nominal volume of 160 l, having the following dimensions (see [Figure 1](#)):

- internal length or depth: (598 ± 8) mm;
- internal diameter: (598 ± 8) mm.

The drum shall be made of minimum 1 mm steel plate. The internal surface area of the drum shall be smooth and any disturbances of the surface such as ridges or furrows shall be avoided.

The durability drum shall be equipped with a rectangular steel baffle having the following dimensions:

- length: (598 ± 8) mm;
- height: (200 ± 2) mm;
- thickness: 2 mm.

The baffle shall be welded on its length to the full height of the internal curved surface of the drum, parallel to the axis of the drum and perpendicular to the tangent of the curve. The baffle tip shall be shaped in a smooth curve of 90° to obtain a rim perpendicular to the baffle. The curve shall have a radius of $r = 10$ mm and the curved tip shall have a total vertical height of 30 mm. The direction of rotation and further details are illustrated in [Figure 1](#).

The drum is open on one of the ends. This opening shall be fitted with a dustproof lid of the same diameter as the internal diameter of the drum (598 ± 8) mm. When the lid is in position, it shall be approximately flush with the side of the cylinder. This lid shall be made of minimum 1 mm steel plate.

It shall be possible to fasten the lid securely by four rotating bolts (or any other suitable mechanism) fixed on the external part of the drum.

The drum shall be capable of being constantly driven at $(21 \pm 0,1)$ r/min by an electric motor, by suitable pulleys or gearings, in order to avoid vibrations. A rotation counter should be connected to the drum.

The rotation counter can also be connected to the motor so that the latter is automatically switched off after a defined number of rotations.

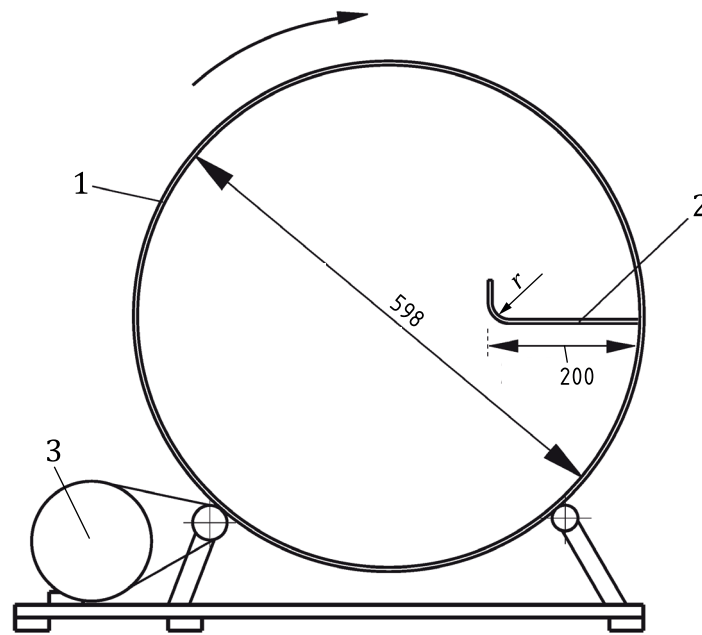
**Key**

- 1 drum
- 2 baffle
- 3 motor

iTeh STANDARD PREVIEW (standards.iteh.ai)

Figure 1 — Principle of the durability drum

ISO 17831-2:2015

<https://standards.iteh.ai/catalog/standards/sist/823d71c3-c531-45e3-b10a-b8845681ba93/iso-17831-2-2015>

5.2 Sieve

Depending on the briquette diameter, a sieve with a metal wire cloth conforming to ISO 3310-1 shall be chosen so that the aperture size is approximately equivalent to $2/3$ of the briquettes diameter or diagonal but not exceeding 45 mm. The sieve is selected from the series between 16 mm and 45 mm in accordance with ISO 3310-1. The sieve shall have a diameter of 400 mm or above.

5.3 Balance

A balance with a weighing capability of at least 2 kg and capable of measuring the mass to the nearest 0,1 g.

6 Test sample preparation

The laboratory sample used for the determination of mechanical durability shall be obtained, and if necessary, divided in mass in accordance with ISO 18135 and prepared in accordance with ISO 14780. The size of the laboratory sample shall conform to the requirements of this part of ISO 17831 (depending on the nominal top size) but shall be at least 25 kg. For briquettes of type A, as defined in [Table 1](#), the minimum required laboratory sample mass shall be 10 kg.

Divide the laboratory sample to obtain two test samples: one to be used for moisture content determination (5 kg), as received, the other for the mechanical durability test. The moisture content as received shall be determined on a non-sieved test sample simultaneously with the durability test; moisture shall be determined in accordance to ISO 18134-1 or ISO 18134-2.

The test sample for durability testing shall be stored in airtight containers to avoid moisture changes. While the test is being conducted, the test sample shall be at room temperature.