



# SLOVENSKI STANDARD

## SIST EN 14960-1:2019

01-julij-2019

Nadomešča:  
SIST EN 14960:2013

---

### Napuhljiva igralna oprema - 1. del: Varnostne zahteve in preskusne metode

Inflatable play equipment - Part 1: Safety requirements and test methods

Aufblasbare Spielgeräte - Teil 1: Sicherheitstechnische Anforderungen und Prüfverfahren

Équipements de jeu gonflables (Partie 1: Exigences de sécurité et méthodes d'essai)

**iTeh STANDARD PREVIEW**

Ta slovenski standard je istoveten z: [SIST EN 14960-1:2019](https://standards.slovenski-institut.si/standards/sist/05/14960-1/2019)  
<https://standards.slovenski-institut.si/standards/sist/05/14960-1/2019>  
[213f189d9611/sist-en-14960-1-2019](https://standards.slovenski-institut.si/standards/sist/05/14960-1/2019) **EN 14960-1:2019**

#### ICS:

97.190	Otroška oprema	Equipment for children
97.200.50	Igrače	Toys

**SIST EN 14960-1:2019**

**en,fr,de**

**iTeh STANDARD PREVIEW**  
**(standards.iteh.ai)**

SIST EN 14960-1:2019

<https://standards.iteh.ai/catalog/standards/sist/051fed0e-ec02-4f6a-87c7-213f189d9611/sist-en-14960-1-2019>

EUROPEAN STANDARD

**EN 14960-1**

NORME EUROPÉENNE

EUROPÄISCHE NORM

May 2019

ICS 97.190; 97.200.50

Supersedes EN 14960:2013

English Version

## Inflatable play equipment - Part 1: Safety requirements and test methods

Équipements de jeu gonflables - Partie 1 : Exigences de  
sécurité et méthodes d'essaiAufblasbare Spielgeräte - Teil 1: Sicherheitstechnische  
Anforderungen und Prüfverfahren

This European Standard was approved by CEN on 15 April 2019.

CEN members are bound to comply with the CEN/CENELEC Internal Regulations which stipulate the conditions for giving this European Standard the status of a national standard without any alteration. Up-to-date lists and bibliographical references concerning such national standards may be obtained on application to the CEN-CENELEC Management Centre or to any CEN member.

This European Standard exists in three official versions (English, French, German). A version in any other language made by translation under the responsibility of a CEN member into its own language and notified to the CEN-CENELEC Management Centre has the same status as the official versions.

CEN members are the national standards bodies of Austria, Belgium, Bulgaria, Croatia, Cyprus, Czech Republic, Denmark, Estonia, Finland, Former Yugoslav Republic of Macedonia, France, Germany, Greece, Hungary, Iceland, Ireland, Italy, Latvia, Lithuania, Luxembourg, Malta, Netherlands, Norway, Poland, Portugal, Romania, Serbia, Slovakia, Slovenia, Spain, Sweden, Switzerland, Turkey and United Kingdom.

<https://standards.iteh.ai/catalog/standards/sist/051fed0e-ec02-4f6a-87c7-213f189d9611/sist-en-14960-1-2019>



EUROPEAN COMMITTEE FOR STANDARDIZATION  
COMITÉ EUROPÉEN DE NORMALISATION  
EUROPÄISCHES KOMITEE FÜR NORMUNG

**CEN-CENELEC Management Centre: Rue de la Science 23, B-1040 Brussels**

<b>Contents</b>	<b>Page</b>
European foreword.....	4
Introduction .....	5
1 Scope.....	6
2 Normative references.....	6
3 Terms and definitions .....	6
4 Safety requirements.....	10
4.1 Materials.....	10
4.1.1 Fabrics.....	10
4.1.2 Thread.....	10
4.1.3 Netting.....	10
4.1.4 Ropes .....	11
4.1.5 Zips .....	11
4.1.6 Dangerous substances and decorative finishes .....	11
4.2 Design.....	11
4.2.1 Anchorage.....	11
4.2.2 Structural integrity.....	12
4.2.3 Access/egress .....	13
4.2.4 Blowers .....	16
4.2.5 Entrapment .....	16
4.2.6 Hard objects, sharp angles and edges.....	21
4.2.7 Electrical installations.....	21
4.2.8 Siting .....	21
4.2.9 Containment.....	23
4.2.10 Wall heights on slopes.....	24
4.2.11 Run-out .....	25
4.2.12 Ventilation .....	25
4.3 Number of users .....	25
4.4 Supervision.....	26
5 Test methods and reports.....	26
6 Information to be provided by the supplier/manufacturer .....	26
6.1 General product information.....	26
6.2 Pre-information.....	27
6.3 Installation information .....	27
6.4 Operating information .....	27
6.5 Inspection and maintenance information.....	28
7 Inspection, maintenance and alteration.....	28
7.1 Inspection .....	28
7.1.1 General.....	28
7.1.2 Routine Inspection.....	28
7.1.3 Annual inspection .....	29
7.2 Maintenance.....	29
7.2.1 General.....	29
7.2.2 Routine maintenance.....	29
7.2.3 Corrective maintenance.....	30

7.3	Alteration.....	30
8	Marking .....	30
9	Documentation .....	31
	Annex A (normative) Calculation of number of anchor-points.....	32
	Annex B (informative) The Beaufort Scale of wind force .....	33
	Annex C (normative) Test method for grounding.....	34
	Annex D (normative) Test methods for entrapment .....	35
D.1	General .....	35
D.2	Head and neck entrapment.....	35
D.3	Entrapment of clothing (Toggle test) .....	42
D.4	Finger entrapment .....	44
	Annex E (normative) Test method for tear strength .....	46
E.1	Maximum value tongue tear, apparatus.....	46
E.2	Preparation of test specimens .....	46
E.3	Conditioning .....	46
E.4	Preconditioning.....	47
E.5	Characteristics of test atmospheres.....	47
E.6	Methods of conditioning .....	47
E.7	Procedure .....	47
E.8	Calculation and expression of results .....	48
E.9	Test report .....	50
	Bibliography .....	51

iteh STANDARD PREVIEW  
(standards.iteh.ai)

SIST EN 14960-1:2019

<https://standards.iteh.ai/catalog/standards/sist/051fed0e-ec02-4f6a-87c7-213f189d9611/sist-en-14960-1-2019>

**EN 14960-1:2019 (E)****European foreword**

This document (EN 14960-1:2019) has been prepared by Technical Committee CEN/TC 136 “Sports, playground and other recreational facilities and equipment”, the secretariat of which is held by DIN.

This European Standard shall be given the status of a national standard, either by publication of an identical text or by endorsement, at the latest by November 2019, and conflicting national standards shall be withdrawn at the latest by November 2019.

Attention is drawn to the possibility that some of the elements of this document may be the subject of patent rights. CEN shall not be held responsible for identifying any or all such patent rights.

This document supersedes – together with EN 14960-2:—<sup>1</sup> and EN 14960-3:—<sup>1</sup> – EN 14960:2013.

In relation to EN 14960:2013, the following main changes have been made:

- a) changes with regard to inflatables sited on hard standing;
- b) minor editing to improve the content accuracy of the document;
- c) splitting this standard into the following three parts:
  - 1) EN 14960-1, *Inflatable play equipment — Part 1: Safety requirements and test methods*;
  - 2) EN 14960-2, *Inflatable play equipment — Part 2: Additional safety requirements for Inflatable Bouncing Pillows for permanent installation* (in preparation);
  - 3) EN 14960-3, *Inflatable play equipment — Part 3: Specific safety requirements and test methods for inflatable snappies* (in preparation).

According to the CEN-CENELEC Internal Regulations, the national standards organisations of the following countries are bound to implement this European Standard: Austria, Belgium, Bulgaria, Croatia, Cyprus, Czech Republic, Denmark, Estonia, Finland, Former Yugoslav Republic of Macedonia, France, Germany, Greece, Hungary, Iceland, Ireland, Italy, Latvia, Lithuania, Luxembourg, Malta, Netherlands, Norway, Poland, Portugal, Romania, Serbia, Slovakia, Slovenia, Spain, Sweden, Switzerland, Turkey and the United Kingdom.

---

<sup>1</sup> Both standards are under development at the time of publication.

## Introduction

Play is the means by which children discover and understand the world in which they live and is an essential element in a child's physical and mental growth.

It is important for children's rounded development that, through play, they arrive at an understanding of danger, which provides a basis for assessing safety in a variety of situations. The balance between challenge and safety is an important consideration.

The inflatable play equipment referred to in this standard can provide different levels of challenge and excitement. This European Standard aims to minimize the level of risk and the possibility of serious injury while allowing children to enjoy themselves when playing in or on inflatable equipment.

This standard acknowledges the difficulties of addressing safety issues by age criteria alone because the ability to handle risk is based on the individual user's level of skill and not age. Moreover, users other than the intended age range will make use of the inflatable equipment, in which case, the provisions of this standard still apply.

It is not the purpose of the requirements of this standard to affect a child's need to play nor to lessen the contribution that inflatable play equipment makes either to the child's development or meaningful play from an educational point of view.

Where inflatable play equipment is combined with other items of children's playground equipment, the relevant standards applying to the other items of equipment should also be consulted.

## iTeh STANDARD PREVIEW (standards.iteh.ai)

SIST EN 14960-1:2019

<https://standards.iteh.ai/catalog/standards/sist/051fed0e-ec02-4f6a-87c7-213f189d9611/sist-en-14960-1-2019>

**EN 14960-1:2019 (E)****1 Scope**

This document is applicable to inflatable play equipment intended for use by children fourteen years and under both individually and collectively.

This document specifies safety requirements for inflatable play equipment for which the primary activities are bouncing and sliding. It sets measures to address risks and also to minimize accidents to users for those involved in the design, manufacture and supply of inflatable play equipment. It specifies information to be supplied with the equipment. The requirements have been laid down bearing in mind the risk factor based on available data.

This document specifies the requirements that will protect a child from hazards that he or she may be unable to foresee when using the equipment as intended, or in a manner that can be reasonably anticipated.

This document is not applicable to inflatable water-borne play and leisure equipment, domestic inflatable toys, air-supported buildings, inflatables used solely for protection, inflatables used for rescue, or other types of inflatable toys where the primary activity is not bouncing or sliding.

**2 Normative references**

The following documents are referred to in the text in such a way that some or all of their content constitutes requirements of this document. For dated references, only the edition cited applies. For undated references, the latest edition of the referenced document (including any amendments) applies.

EN 71-3, *Safety of toys — Part 3: Migration of certain elements*

EN 1177, *Impact attenuating playground surfacing — Determination of critical fall height*

EN 60529, *Degrees of protection provided by enclosures (IP code) (IEC 60529)*

EN ISO 1421, *Rubber- or plastics-coated fabrics — Determination of tensile strength and elongation at break (ISO 1421)*

EN ISO 2307, *Fibre ropes — Determination of certain physical and mechanical properties (ISO 2307)*

EN ISO 2411, *Rubber- or plastics-coated fabrics — Determination of coating adhesion (ISO 2411)*

EN ISO 9554, *Fibre ropes — General specifications (ISO 9554)*

EN ISO/IEC 17025:2017, *General requirements for the competence of testing and calibration laboratories (ISO/IEC 17025:2017)*

**3 Terms and definitions**

For the purposes of this document, the following terms and definitions apply.

**NOTE** In order not to confine the application of this European Standard to those items of equipment currently in use and hence allow freedom of design for the manufacture of new equipment, only the fundamental forms of equipment and motion are listed.



ISO and IEC maintain terminological databases for use in standardization at the following addresses:

- IEC Electropedia: available at <http://www.electropedia.org/>
- ISO Online browsing platform: available at <http://www.iso.org/obp>

### 3.1

#### **inflatable play equipment**

structure relying on a continuous supply of air to maintain its shape, on or in which users may play, bounce and/or slide

Note 1 to entry: Also referred to as an/the inflatable.

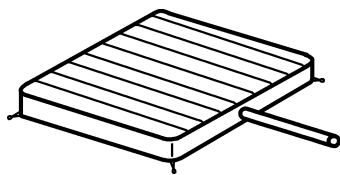

a) Flat-bed  
(4 open sides)

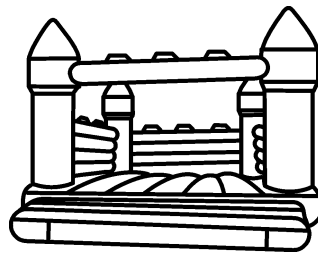

b) Castle  
(3 walled sides, 1 open side)

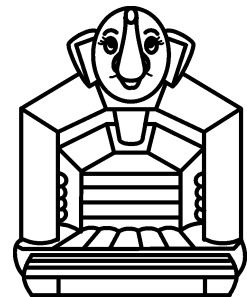

c) A-Frame inflatable  
(3 walled sides, 1 open side)

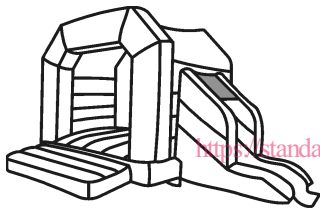

d) Bounce/Slide combination

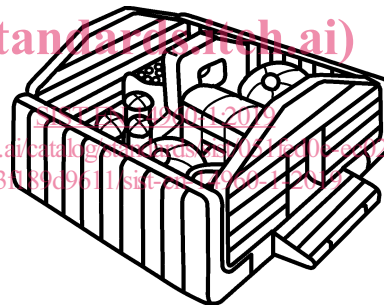

e) Multi-Play Centre

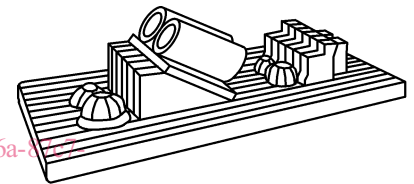

f) Obstacle course

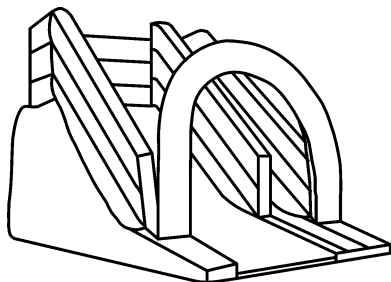

g) Inflatable slide



h) Enclosed inflatable

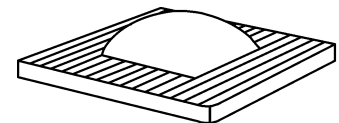

i) Soft mountain

Figure 1 — Examples of inflatable play equipment

### 3.2

#### **blower**

powered machine used to continuously inflate the structure

**EN 14960-1:2019 (E)****3.3****connection tube**

part of the inflatable structure to which the blower is connected

**3.4****controller**

person, company or hirer (those who hire to others), having responsibility for the overall control, inspection and maintenance of the equipment

**3.5****operator**

person appointed by a controller to be in charge of the operation of the equipment at any time when it is available for use by the public

**3.6****attendant**

person working under the control and direction of an operator to assist in the operation of the equipment

**3.7****inspection body**

organisation, part of an organisation or individual with the appropriate competence to carry out one or more of the following inspections:

— design review;

— assessment of conformity to design;

— initial testing;

— annual main inspection

**iTeh STANDARD PREVIEW**  
**(standards.iteh.ai)**

[SIST EN 14960-1:2019](https://standards.iteh.ai/catalog/standards/sist/051fed0e-ec02-4f6a-87c7-213f189d9611/sist-en-14960-1-2019)

<https://standards.iteh.ai/catalog/standards/sist/051fed0e-ec02-4f6a-87c7-213f189d9611/sist-en-14960-1-2019>

**3.8****free height of fall**

greatest vertical distance from the clearly intended body support to the impact area below

[SOURCE: EN 1176-1:2008, 3.6]

**3.9****critical fall height**

maximum free heights of fall, for which a surface will provide an acceptable level of impact attenuation

**3.10****open side**

any external side of an inflatable with no containing wall

**3.11****step**

step to aid the access/egress of users into and out of the playing area of the inflatable, making the transition between the height of the playing area and the ground

**3.12****ramp**

ramp to aid the access/egress of users into and out of the playing area of the inflatable, making the transition between the height of the playing area and the ground

**3.13****platform**

any surface on which a user may stand

**3.14****squeeze**

play item which is often attached to and forms part of inflatable play equipment, the purpose of which is to squeeze the user whilst not entrapping them while allowing the user to pass through a gap with a degree of difficulty

**3.15****entrapment**

hazard in which a body, or part of a body, or clothing, can become trapped

**3.16****impact area**

area surrounding the open side(s) of an inflatable

**3.17****run-out**

intended deceleration zone at the bottom of a slide

**iTeh STANDARD PREVIEW**  
(standards.iteh.ai)

**3.18**

**anchorage system** <https://standards.iteh.ai/catalog/standards/sist/051fed0e-ec02-4f6a-87c7-113618949a11/sist-en-14960-1-2019>  
method of fixing an inflatable to the ground using stakes

**3.19****ballast system**

method of fixing an inflatable to the ground using weights

**3.20****user height**

maximum height of persons allowed to use the inflatable

**3.21****free space**

space in, on or around the inflatable that can be occupied by a user undergoing a movement forced by the equipment (for example sliding, bouncing)

**3.22****playing area**

space in or on the inflatable, intended for play

**3.23****falling space**

space in, or around the inflatable that can be passed through by a user falling from an elevated part of the equipment

Note 1 to entry: The falling space commences at the free height of fall.

## EN 14960-1:2019 (E)

## 4 Safety requirements

### 4.1 Materials

#### 4.1.1 Fabrics

Fabrics shall be flame retardant.

Fabrics, and joins in fabrics, shall be of adequate tear and tensile strength for the weight of the intended user and have sufficient air retention to enable the inflatable, when pressurized to the level specified in the operations manual, to resume its shape after distortion under load.

Fabrics of:

- minimum tear strength 350 N (see test method Annex E),
- minimum tensile strength 1 850 N (see EN ISO 1421),
- minimum coating adhesion 100 N (see EN ISO 2411),

shall be used in those structural parts of the inflatable where force or stress is applied by the user.

#### 4.1.2 Thread

Threads shall be non-rotting yarn and at least 88 N tensile strength. Stitching shall be lock-stitch. The length of individual stitches shall be a minimum of 3 mm and a maximum of 8 mm.

#### 4.1.3 Netting

Retention netting is commonly used to define the playing area, to contain the users and to retain items of mobile play equipment such as balls. Retention netting shall not significantly impair visibility. Retention netting shall be strong enough to contain the largest/heaviest user for whom the inflatable is designed.

In order to prevent users from climbing retention netting the mesh size, where the netting is more than 1 m vertical height and accessible to the user, shall be 30 mm or less to exclude users' feet.

Where netting is used for roofs and is accessible to the user, the mesh size shall be small enough to prevent the 8 mm finger rod from passing through (see Figure 2).

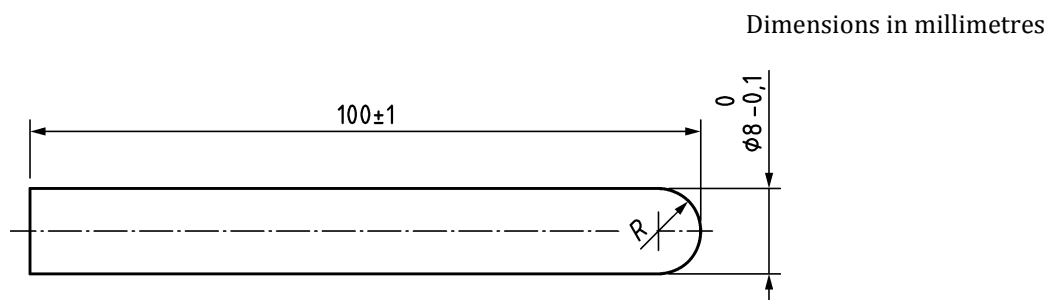

**Figure 2 — 8 mm finger rod**

Clamber netting (commonly laid on slopes to form foot and hand holds) shall be securely fixed to prevent lifting by the user. The rope from which it is made shall be at least 12 mm in diameter and shall be securely knotted. Strand ends shall be treated to prevent fraying. Care shall be taken when heat sealing so as not to form hard or sharp edges.

#### 4.1.4 Ropes

Ropes shall be fixed at both ends and the total amplitude of swing shall not exceed 20 % of the distance between the fixing points such that it shall not be possible to make a loop in the rope of large enough diameter to allow probe E to pass through (see Figure D.1).

NOTE This requirement is intended to remove the risk of strangulation.

The rope diameter shall be between 18 mm and 45 mm.

Fibre ropes (textile type) shall conform to EN ISO 9554 or EN ISO 2307. Alternatively, a works certificate shall be supplied stating the material used and the safe working load. Monofilament plastics ropes shall not be used.

#### 4.1.5 Zips

Zips shall withstand air pressures and tension generated within the structure. Zips used for entrances and exits shall be reliable, easy to use, able to open from both sides and shall allow access and egress by adults. Zips used for deflation purposes shall have the puller hidden from view (e.g. by a flap or pocket).

#### 4.1.6 Dangerous substances and decorative finishes

Dangerous substances shall not be used for inflatable play equipment in such a way that they can cause adverse health affects to the user. Paints and other decorative finishes shall conform to EN 71-3.

NOTE Attention is drawn to the provisions of European Regulation (EC) No. 1907/2006 [2]. Such materials include, for example, asbestos, lead, formaldehyde, coal tar oils, carbolineums and polychlorinated biphenyls (PCBs).

(standards.iteh.ai)

## 4.2 Design

### 4.2.1 Anchorage SIST EN 14960-1:2019 <https://standards.iteh.ai/catalog/standards/sist/051fed0e-ec02-4f6a-87c7-213f189d9611/sist-en-14960-1-2019>

The inflatable shall be provided with an anchorage and/or ballast system and any necessary accessories enabling the inflatable to be securely fixed to the ground. Each inflatable shall have at least six anchorage points.

The number of anchorage points shall be calculated in accordance with Annex A. They shall be distributed around the perimeter of the inflatable (see also 4.2.3) and shall be fitted with metal ends. The maximum wind- speed in which inflatables shall be used outdoors is 38 km/h (Force 5 on the Beaufort Scale); see Annex B.

When used outdoors, the inflatable shall be secured to the ground, preferably with ground stakes where the ground is suitable. Each anchorage point on the inflatable and all of the components of the anchorage and/or ballast system, e.g. ropes, webbings, metal attachments, stakes, weights, shall withstand a force of 1 600 N. The direction of the exerted force shall be at an angle to the ground of 30° to 45°. Ground stakes shall incline away from the direction of the exerted force. Ground stakes shall be a minimum of 380 mm in length and a minimum of 16 mm in diameter and their tops shall be rounded. The system shall expose no more than 25 mm of the stake above ground level (see Figure 3).

When the inflatable is used indoors, the anchorage and/or ballast system should be used, when necessary, to maintain stability.

Dimensions in millimetres

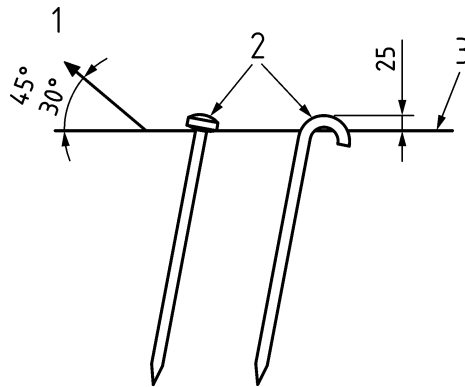
**Key**

- 1 direction of force
- 2 rounded tops
- 3 ground level

**Figure 3 — Examples of ground stakes**

On hard standing where ground stakes cannot be used, the inflatable shall be secured to the ground by equally effective method, e.g. attaching each of the anchorage points to fittings already in the ground, or to sandbags or other weights, if these are capable of supporting the 1 600 N load. If the inflatable is secured to a vehicle or other movable machinery, such vehicles or machinery shall be immobilised and be under the control of an operator.

**4.2.2 Structural integrity**

SIST EN 14960-1:2019

<https://standards.iteh.ai/catalog/standards/sist/051fed0e-ec02-4f6a-87c7-017809a62061>

The minimum air pressure inside the structural parts of the inflatable shall be 1 kPa (100 mm water gauge). Inflated chambers that are entered by the user are not considered to be structural parts of the inflatable, e.g. enclosed dome type inflatables. Pressure in the playing area of soft mountains shall be no greater than 0,25 kPa (25 mm water gauge), but shall maintain a pressure sufficient to prevent grounding. Pressure in the surrounding safety apron of soft mountains shall be at least 1 kPa (100 mm water gauge); see Figure 4.

The depth of the trough on the surface of any platform shall be a maximum of 33 % of the width of the adjacent panel, measured when inflated (see Figure 5).

Containing walls shall be vertical ( $90 \pm 5$ )°. Towers that support containing walls shall be in the same plane. Containing walls and towers shall be strong enough to contain the largest and/or heaviest user for whom the inflatable is designed.

Playing areas, surrounding safety aprons, steps and/or ramps shall support the weight of the largest and/or heaviest user for whom the inflatable is designed, without grounding. See Annex C for the test method.

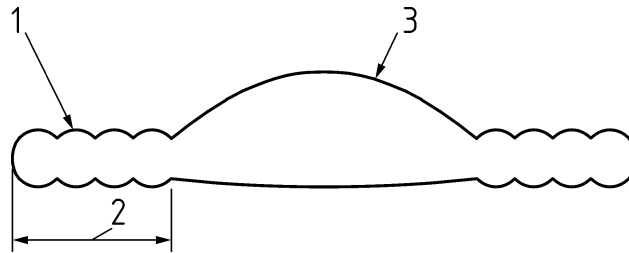
**Key**

- 1 surrounding safety apron
- 2 tread depth
- 3 playing area

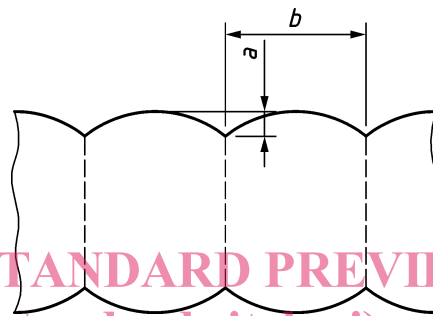
**Figure 4 — Section through a soft mountain**

iTeh STANDARD PREVIEW  
(standards.iteh.ai)

**Key**

- a depth of trough — measured when inflated
  - b width of adjacent panel
- SIST EN 14960-1:2019  
<https://standards.iteh.ai/catalog/standards/sist/051fed0e-ec02-4f6a-87c7-213f189d9611/sist-en-14960-1-2019>

**Figure 5 — Trough depth****4.2.3 Access/egress**

A step or ramp shall be wide enough to cover the entire access/egress aperture with overlap, according to Figure 6.

A step or ramp shall have a tread depth of a minimum of 1,5 times the height of the adjacent playing area platform to which it is attached (see Figure 6).

The playing area of soft mountains shall be completely surrounded by an inflated safety apron. This safety apron shall have a minimum tread depth of 1,6 m or 0,5 times the height of the playing area measured from the ground when inflated and in the unloaded condition, whichever is greater.

In the event of air supply failure, the deflation time shall be sufficient to allow users of the inflatable to be evacuated safely.

**NOTE** Deflation time can be considerably lengthened by inserting a non-return flap in the outlet nozzle of the blower or at the joint of the connection tube and structure.

Inflatables shall be designed to ensure that adults are able to gain access in order to assist users.

On any open side, the free height of fall shall be no greater than 630 mm from the ground in the unloaded condition, (600 mm in the loaded condition).