



Designation: E 384 – 08a

## Standard Test Method for Microindentation Hardness of Materials<sup>1</sup>

This standard is issued under the fixed designation E 384; the number immediately following the designation indicates the year of original adoption or, in the case of revision, the year of last revision. A number in parentheses indicates the year of last approval. A superscript epsilon ( $\epsilon$ ) indicates an editorial change since the last revision or reapproval.

*This standard has been approved for use by agencies of the Department of Defense.*

### 1. Scope\*

1.1 This test method covers determination of the microindentation hardness of materials, the verification of microindentation hardness testing machines, and the calibration of standardized test blocks.

1.2 This test method covers microindentation tests made with Knoop and Vickers indenters under test forces in the range from  $9.8 \times 10^{-3}$  to 9.8 N (1 to 1000 gf).

1.3 This test method includes an analysis of the possible sources of errors that can occur during microindentation testing and how these factors affect the accuracy, repeatability, and reproducibility of test results.

NOTE 1—While Committee E04 is primarily concerned with metals, the test procedures described are applicable to other materials.

1.4 *This standard does not purport to address all of the safety concerns, if any, associated with its use. It is the responsibility of the user of this standard to establish appropriate safety and health practices and determine the applicability of regulatory limitations prior to use.*

### 2. Referenced Documents

- 2.1 *ASTM Standards:*<sup>2</sup>
- C 1326 Test Method for Knoop Indentation Hardness of Advanced Ceramics
  - C 1327 Test Method for Vickers Indentation Hardness of Advanced Ceramics
  - E 3 Guide for Preparation of Metallographic Specimens
  - E 7 Terminology Relating to Metallography
  - E 122 Practice for Calculating Sample Size to Estimate, With Specified Precision, the Average for a Characteristic of a Lot or Process

<sup>1</sup> This test method is under the jurisdiction of ASTM Committee E04 on Metallography and is the direct responsibility of Subcommittee E04.05 on Microindentation Hardness Testing.

Current edition approved March 15, 2008. Published April 2008. Originally approved in 1969. Last previous edition approved in 2008 as E 384 – 08.

<sup>2</sup> For referenced ASTM standards, visit the ASTM website, www.astm.org, or contact ASTM Customer Service at service@astm.org. For *Annual Book of ASTM Standards* volume information, refer to the standard's Document Summary page on the ASTM website.

- E 140 Hardness Conversion Tables for Metals Relationship Among Brinell Hardness, Vickers Hardness, Rockwell Hardness, Superficial Hardness, Knoop Hardness, and Scleroscope Hardness
- E 175 Terminology of Microscopy
- E 691 Practice for Conducting an Interlaboratory Study to Determine the Precision of a Test Method
- E 766 Practice for Calibrating the Magnification of a Scanning Electron Microscope

### 3. Terminology

3.1 *Definitions*—For definitions of terms used in this test method, see Terminology E 7.

3.2 *Definitions of Terms Specific to This Standard:*

3.2.1 *calibrating,  $v$* —determining the values of the significant parameters by comparison with values indicated by a reference instrument or by a set of reference standards.

3.2.2 *Knoop hardness number, HK,  $n$* —an expression of hardness obtained by dividing the force applied to the Knoop indenter by the projected area of the permanent impression made by the indenter.

3.2.3 *Knoop indenter,  $n$* —a rhombic-based pyramidal-shaped diamond indenter with edge angles of  $\angle A = 172^\circ 30'$  and  $\angle B = 130^\circ 0'$  (see Fig. 1).

3.2.4 *microindentation hardness test,  $n$* —a hardness test using a calibrated machine to force a diamond indenter of specific geometry into the surface of the material being evaluated, in which the test forces range from 1 to 1000 gf ( $9.8 \times 10^{-3}$  to 9.8 N), and the indentation diagonal, or diagonals are measured with a light microscope after load removal; for any microindentation hardness test, it is assumed that the indentation does not undergo elastic recovery after force removal.

NOTE 2—Use of the term microhardness should be avoided because it implies that the hardness, rather than the force or the indentation size, is very low.

3.2.5 *verifying,  $v$* —checking or testing the instrument to assure conformance with the specification.

3.2.6 *Vickers hardness number, HV,  $n$* —an expression of hardness obtained by dividing the force applied to a Vickers indenter by the surface area of the permanent impression made by the indenter.

\*A Summary of Changes section appears at the end of this standard.

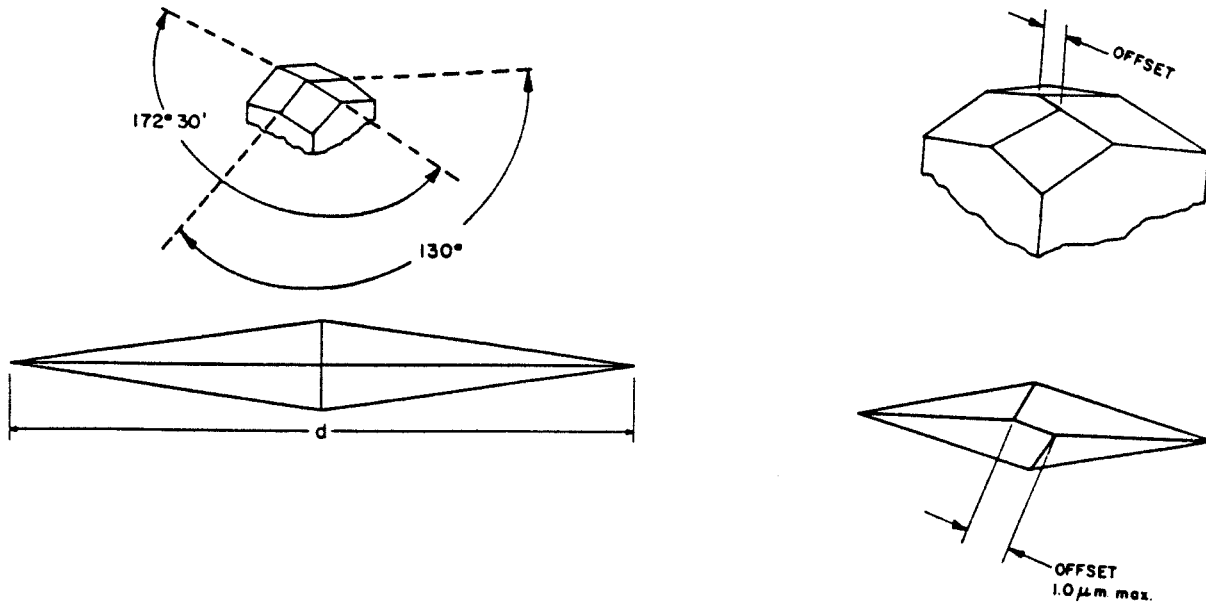

FIG. 1 Knoop Indenter

3.2.7 *Vickers indenter, n*—a square-based pyramidal-shaped diamond indenter with face angles of 136° (see Fig. 2).

3.3 *Formulae*—The formulae presented in 3.3.1-3.3.4 for calculating microindentation hardness are based upon an ideal tester. The measured value of the microindentation hardness of a material is subjected to several sources of errors. Based on Eq 1-9, variations in the applied force, geometrical variations between diamond indenters, and human errors in measuring indentation lengths can affect the calculated material hardness. The amount of error each of these parameters has on the calculated value of a microindentation measurement is discussed in Section 10.

3.3.1 For Knoop hardness tests, in practice, test loads are in grams-force and indentation diagonals are in micrometers. The Knoop hardness number is calculated using the following:

$$HK = 1.000 \times 10^3 \times (P/A_p) = 1.000 \times 10^3 \times P/(c_p \times d^2) \quad (1)$$

$$HK = 14229 \times P/d^2 \quad (2)$$

$$c_p = \frac{\tan\left(\frac{\angle B}{2}\right)}{2 \tan\left(\frac{\angle A}{2}\right)} \quad (3)$$

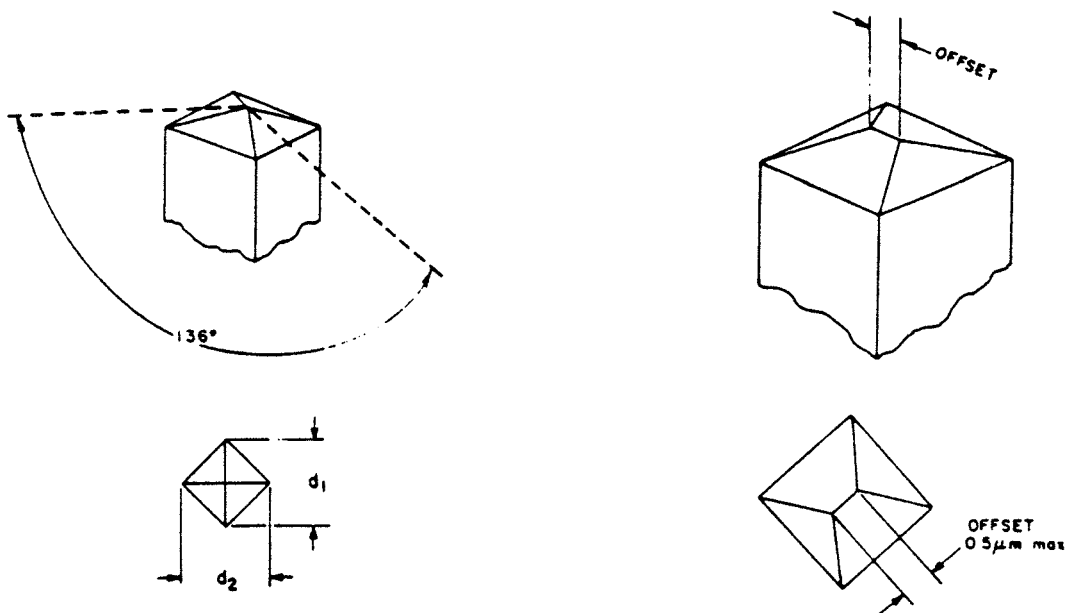

FIG. 2 Vickers Indenter

where:

- $P$  = force, gf,
- $d$  = length of long diagonal,  $\mu\text{m}$ ,
- $A_p$  = projected area of indentation,  $\mu\text{m}^2$ ,
- $\angle A$  = included longitudinal edge angle,  $172^\circ 30'$ ,
- $\angle B$  = included transverse edge angle,  $130^\circ 0'$  (see Fig. 1), and
- $c_p$  = indenter constant relating projected area of the indentation to the square of the length of the long diagonal, ideally 0.07028.

NOTE 3—HK values for a 1-gf ( $9.8 \times 10^{-3}$  N) test are contained in Appendix X6. To obtain HK values when other test forces are employed, multiply the HK value from Table X6.1 for the  $d$  value by the actual test force, g.

3.3.2 The Knoop hardness,  $\text{kgf}/\text{mm}^2$  is determined as follows:

$$\text{HK} = 14.229 \times P_1/d_1^2 \quad (4)$$

where:

- $P_1$  = force, kgf, and
- $d_1$  = length of long diagonal, mm.

3.3.3 The Knoop hardness reported with units of GPa is determined as follows:

$$\text{HK} = 0.014229 \times P_2/d_2^2 \quad (5)$$

where:

- $P_2$  = force, N, and
- $d_2$  = length of the long diagonal of the indentation, mm.

3.3.4 For the Vickers hardness test, in practice, test loads are in grams-force and indentation diagonals are in micrometres. The Vickers hardness number is calculated as follows:

$$\text{HV} = 1.000 \times 10^3 \times P/A_s = 2.000 \times 10^3 \times P \sin(\alpha/2)/d^2 \quad (6)$$

or

$$\text{HV} = 1854.4 \times P/d^2 \quad (7)$$

where:

- $P$  = force, gf,
- $A_s$  = surface area of the indentation,  $\mu\text{m}^2$ ,
- $d$  = mean diagonal length of the indentation,  $\mu\text{m}$ , and
- $\alpha$  = face angle of the indenter,  $136^\circ 0'$  (see Fig. 2).

NOTE 4—HV numbers for a 1-gf ( $9.8 \times 10^{-3}$  N) test load are contained in Appendix X6. To obtain HV values when other test forces are employed, multiply the HV value from Table X6.2 for the  $d$  value by the actual test force, g.

3.3.5 The Vickers hardness,  $\text{kgf}/\text{mm}^2$  is determined as follows:

$$\text{HV} = 1.8544 \times P_1/d_1^2 \quad (8)$$

where:

- $P_1$  = force, kgf, and
- $d_1$  = mean diagonal length of the indentations, mm.

3.3.6 The Vickers hardness reported with units of GPa is determined as follows:

$$\text{HV} = 0.0018544 \times P_2/d_2^2 \quad (9)$$

where:

- $P_2$  = force, N, and

$d_2$  = mean diagonal length of the indentations, mm.

## 4. Summary of Test Method

4.1 In this test method, a hardness number is determined based on the formation of a very small indentation by application of a relatively low force, in comparison to ordinary indentation hardness tests.

4.2 A Knoop or Vickers indenter, made from diamond of specific geometry is pressed into the test specimen surface under an applied force in the range of 1 to 1000 gf using a test machine specifically designed for such work.

4.3 The size of the indentation is measured using a light microscope equipped with a filar type eyepiece, or other type of measuring device (see Terminology E 175).

4.4 The Knoop hardness number is based upon the force divided by the projected area of the indentation. The Vickers hardness number is based upon the force divided by the surface area of the indentation.

4.5 It is assumed that elastic recovery does not occur when the indenter is removed after the loading cycle, that is, it is assumed that the indentation retains the shape of the indenter after the force is removed. In Knoop testing, it is assumed that the ratio of the long diagonal to the short diagonal of the impression is the same (see 7.1.4) as for the indenter.

## 5. Significance and Use

5.1 Hardness tests have been found to be very useful for materials evaluation, quality control of manufacturing processes and research and development efforts. Hardness, although empirical in nature, can be correlated to tensile strength for many metals, and is an indicator of wear resistance and ductility.

5.2 Microindentation tests extend hardness testing to materials too thin or too small for macroindentation tests. Microindentation tests allow specific phases or constituents and regions or gradients too small for macroindentation testing to be evaluated.

5.3 Because the microindentation hardness will reveal hardness variations that may exist within a material, a single test value may not be representative of the bulk hardness.

## 6. Apparatus

6.1 *Test Machine*—The test machine must support the test specimen and control the movement of the indenter into the specimen under a preselected test force, and should have a light optical microscope to select the desired test location and to measure the size of the indentation produced by the test. The plane of the surface of the test specimen must be perpendicular to the axis of the indenter and the direction of the force application. The plane of the test surface of test specimen must be level in order to obtain usable information.

6.1.1 *Force Application*—The test machine shall be capable of applying the following forces:

6.1.1.1 The time from the initial application of the force until the full test force is reached shall not exceed 10 s.

6.1.1.2 The indenter shall contact the specimen at a velocity between 15 and 70  $\mu\text{m}/\text{s}$ .

6.1.1.3 The full test force shall be applied for 10 to 15 s unless otherwise specified.

6.1.1.4 For some applications it may be necessary to apply the test force for longer times. In these instances the tolerance for the time of the applied force is  $\pm 2$  s.

6.1.2 *Vibration Control*—During the entire test cycle, the test machine should be protected from shock or vibration. To minimize vibrations, the operator should avoid contacting the machine in any manner during the entire test cycle.

6.2 *Vickers Indenter*—The Vickers indenter usually produces a geometrically similar indentation at all test forces. Except for tests at very low forces that produce indentations with diagonals smaller than about 25  $\mu\text{m}$ , the hardness number will be essentially the same as produced by Vickers machines with test forces greater than 1 kgf, as long as the material being tested is reasonably homogeneous. For isotropic materials, the two diagonals of a Vickers indentation are equal in size.

6.2.1 The ideal Vickers indenter is a highly polished, pointed, square-based pyramidal diamond with face angles of  $136^\circ 0'$ . The effect that geometrical variations of these angles have on the measured values of Vickers hardness are discussed in Section 10.

6.2.2 The four faces of the Vickers indenter shall be equally inclined to the axis of the indenter (within  $\pm 30'$ ) and shall meet at a sharp point. The line of junction between opposite faces (offset) shall be not more than 0.5  $\mu\text{m}$  in length as shown in Fig. 2.

6.3 *Knoop Indenter*—The Knoop indenter does not produce a geometrically similar indentation as a function of test force. Consequently, the Knoop hardness will vary with test force. Due to its rhombic shape, the indentation depth is shallower for a Knoop indentation compared to a Vickers indentation under identical test conditions. The two diagonals of a Knoop indentation are markedly different. Ideally, the long diagonal is 7.114 times longer than the short diagonal, but this ratio is influenced by elastic recovery. Thus, the Knoop indenter is very useful for evaluating hardness gradients or thin coatings.

6.3.1 The Knoop indenter is a highly polished, pointed, rhombic-based, pyramidal diamond. The ideal included longitudinal edge angles are  $172^\circ 30'$  and  $130^\circ 0'$ . The ideal indenter constant,  $c_p$ , is 0.07028. The effect that geometrical variations of these angles have on the measured values of Knoop hardness are discussed in Section 10.

6.3.2 The four faces of the Knoop indenter shall be equally inclined to the axis of the indenter (within  $\pm 30'$ ) and shall meet at a sharp point. The line of junction between opposite faces (offset) shall be not more than 1.0  $\mu\text{m}$  in length for indentations greater than 20  $\mu\text{m}$  in length, as shown in Fig. 1. For shorter indentations the offset should be proportionately less.

6.3.3 Indenters should be examined periodically and replaced if they become worn, dulled, chipped, cracked or separated from the mounting material.

6.4 *Measuring Equipment*—The test machine's measuring device should report the diagonal lengths in 0.1  $\mu\text{m}$  increments for indentations with diagonals from 1 to 200  $\mu\text{m}$ .

NOTE 5—This is the reported length and not the resolution of the system used for performing the measurements. As an example, if a length of 200  $\mu\text{m}$  corresponds to 300 filar units or pixels, the corresponding calibration constant would be  $200/300 = 0.66666667$ . This value would be

used to compute diagonal lengths, but the reported length would only be reported to the nearest 0.1  $\mu\text{m}$ .

6.4.1 The optical portion of the measuring device should have Köhler illumination (see Appendix X1).

6.4.2 To obtain maximum resolution, the measuring microscope should have adjustable illumination intensity, adjustable alignment and aperture and field diaphragms.

6.4.3 Magnifications should be provided so that the diagonal can be enlarged to greater than 25 % but less than 75 % of the field width.

## 7. Test Specimen

7.1 For optimum accuracy of measurement, the test should be performed on a flat specimen with a polished or otherwise suitably prepared surface. The surface must be free of any defects that could affect the indentation or the subsequent measurement of the diagonals. Conducting tests on non-planar surfaces is not recommended. Results will be affected even in the case of the Knoop test where the radius of curvature is in the direction of the short diagonal.

7.1.1 In all tests, the indentation perimeter, and the indentation tips in particular, must be clearly defined in the microscope field of view.

7.1.2 The specimen surface should not be etched before making an indentation. Etched surfaces can obscure the edge of the indentation, making an accurate measurement of the size of the indentation difficult. However, when determining the microindentation hardness of an isolated phase or constituent, a light etch can be used to delineate the object of interest. The quality of the required surface finish can vary with the forces and magnifications used in microindentation hardness testing. The lighter the force and the smaller the indentation size, the more critical is the surface preparation. Some materials are more sensitive to preparation-induced damage than others.

7.1.3 Due to the small size of the indentations, special precautions must be taken during specimen preparation. It is well known that improper polishing can alter test results. Specimen preparation must remove any damage introduced during these steps, either due to excessive heating or cold work, for example.

7.1.4 Specimen preparation should be performed in accordance with Methods E 3.

7.2 In some instances, it is necessary to mount the specimen for convenience in preparation. When mounting is required, the specimen must be adequately supported by the mounting medium so that the specimen does not move during force application, that is, avoid the use of polymeric mounting compounds that creep under the indenter force.

## 8. Procedure

8.1 Turn on the illumination system and power for the tester.

8.2 Select the desired indenter. Refer to the manufacturer's instruction manual if it is necessary to change indenters. Occasionally clean the indenter with a cotton swab and alcohol. Avoid creating static charges during cleaning.

8.3 Place the specimen on the stage or in the stage clamps, so that the specimen surface is perpendicular to the indenter axis.

8.4 Focus the measuring microscope with a low power objective so that the specimen surface can be observed.

8.5 Adjust the light intensity and adjust the apertures for optimum resolution and contrast.

8.6 Select the area desired for hardness determination. Before applying the force, make a final focus using the measuring objective or the highest magnification objective available.

8.7 Adjust the tester so that the indenter is in the proper place for force application. Select the desired force.

8.8 Activate the tester so that the indenter is automatically lowered and makes contact with the specimen for the normally required time period. Then, remove the force either manually or automatically.

8.9 After the force is removed, switch to the measuring mode, and select the proper objective lens. Focus the image, adjust the light intensity if necessary, and adjust the apertures for maximum resolution and contrast.

8.10 Examine the indentation for its position relative to the desired location and for its symmetry.

8.10.1 If the indentation did not occur at the desired spot, the tester is out of alignment. Consult the manufacturer's instruction manual for the proper procedure to produce alignment. Make another indentation and recheck the indentation location. Readjust and repeat as necessary.

8.10.2 For a Knoop indentation, if one half of the long diagonal is greater than 10 % longer than the other, or if both ends of the indentation are not in sharp focus, the test specimen surface may not be perpendicular to the indenter axis. Check the specimen alignment and make another test.

8.10.3 For a Vickers indentation, if one half of either diagonal is more than 5 % longer than the other half of that diagonal, or if the four corners of the indentation are not in sharp focus, the test surface may not be perpendicular to the indenter axis. Check the specimen alignment and make another test.

8.10.4 If the diagonal legs are unequal as described in 8.10.2 or 8.10.3, rotate the specimen 90° and make another indentation in an untested region. If the nonsymmetrical aspect of the indentations has rotated 90°, then the specimen surface is not perpendicular to the indenter axis. If the nonsymmetrical nature of the indentation remains in the same orientation, check the indenter for misalignment or damage.

8.10.5 Some materials may have nonsymmetrical indentations even if the indenter and the specimen surface are perfectly aligned. Tests on single crystals or on textured materials may produce such results. When this occurs, check the alignment using a test specimen, such as a standard, known to produce uniformly shaped indentations.

8.10.6 Brittle materials such as ceramics may crack as a result of being indented. Specific details for testing ceramics are contained in Test Methods C 1326 and C 1327.

8.11 Measure the long diagonal of a Knoop indentation, or both diagonals of a Vickers indentation, in accordance with the manufacturer's instruction manual.

8.11.1 Determine the length of the long diagonal of a Knoop indentation or both diagonals of a Vickers indentation to within

0.1 μm (see 6.3). For the Vickers indentations, average the two diagonal length measurements.

8.12 Compute the Knoop or Vickers hardness number using the appropriate equation in Section 3 or Table X6.1 or Table X6.2, respectively. Table X6.1 and Table X6.2 show the Knoop or Vickers hardness for indentations with diagonal lengths from 1 to 200.9 μm using 1 gf. If the force was not 1 gf, multiply the value from Table X6.1 or Table X6.2 by the actual gram-force value to obtain the correct hardness number.

8.13 *Spacing of Indentations*—Generally more than one indentation is made on a test specimen. It is necessary to ensure that the spacing between indentations is large enough so that adjacent tests do not interfere with each other.

8.13.1 For most testing purposes, the minimum recommended spacing between separate tests, and minimum distance between an indentation and the surface of the specimen are illustrated in Fig. 3.

8.13.2 For some applications, closer spacing of indentations than those shown in Fig. 3 may be desired. If closer indentation spacings are used, it shall be the responsibility of the testing laboratory to verify the accuracy of the testing procedure.

## 9. Report

9.1 Report the following information:

9.1.1 The test results, the number of tests, and, where appropriate, the mean and standard deviation of the tests,

9.1.2 Test force, and

9.1.3 Any unusual conditions encountered during the test.

9.2 The symbols HK for Knoop hardness, and HV for Vickers hardness shall be used with the reported numerical values.

9.2.1 For this standard, the microindentation hardness test results can be reported in several different ways. For example, if the Knoop hardness was found to be 400, and the test force was 100 gf, the test results may be reported as follows:

9.2.1.1 In the Kilogram force system: 400 HK 0.1.

9.2.1.2 In the gram force system: 400 HK 100 gf.

9.2.1.3 In the SI system: 3.92 GPa.

9.2.2 For nonstandard dwell times, other than 10 to 15 s, the hardness would be reported as 400 HK 0.1 /22 s. In this case, 22 s would be the actual time of full load dwell time.

## 10. Precision and Bias

10.1 The precision and bias of microindentation hardness measurements depend on strict adherence to the stated test procedure and are influenced by instrumental and material factors and indentation measurement errors.

10.2 The consistency of agreement for repeated tests on the same material is dependent on the homogeneity of the material, reproducibility of the hardness tester, and consistent, careful measurement of the indents by a competent operator.

10.3 Instrumental factors that can affect test results include: accuracy of loading; inertia effects; speed of loading; vibrations; the angle of indentation; lateral movement of the indenter or specimen; indentation and indenter shape deviations.

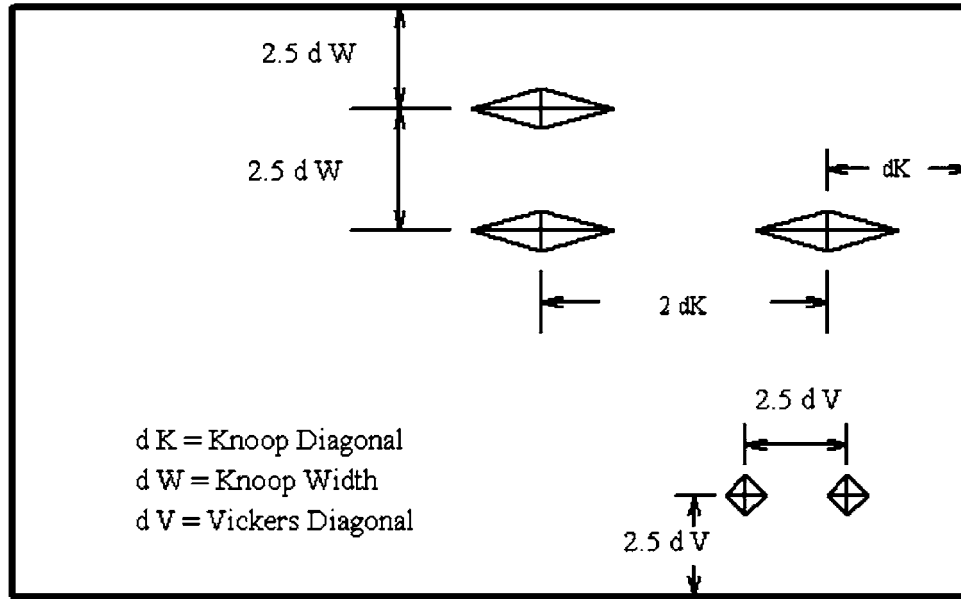

FIG. 3 Minimum Recommended Spacing for Knoop and Vickers Indentations

10.3.1 Vibrations during indenting will produce larger indentations with the influence of vibrations becoming larger as the force decreases (1, 2).<sup>3</sup>

10.3.2 The angle between the indenter and specimen surface should be within  $2^\circ$  of perpendicular. Greater amounts of tilting produce nonuniform indentations and invalid test results.

10.4 Material factors that can affect test results include: specimen homogeneity, orientation or texture effects; improper specimen preparation; low specimen surface reflectivity; transparency of the specimen.

10.4.1 Residual deformation from mechanical polishing must be removed, particularly for low-force testing.

10.4.2 Distortion of the indentation shape due to either crystallographic or microstructural texture influences diagonal lengths and the validity of the calculated hardness.

10.4.3 Plastic deformation during indentation can produce ridging around the indentation periphery that will affect diagonal measurement accuracy.

10.4.4 Testing of etched surfaces, depending on the extent of etching, can produce results that are different from those obtained on unetched surfaces (1).

10.5 Measurement errors that can affect test results include: inaccurate calibration of the measuring device; inadequate resolving power of the objective; insufficient magnification; operator bias in sizing the indentations; poor image quality; nonuniform illumination, improper zeroing of the measuring device.

10.5.1 The accuracy of microindentation hardness testing is strongly influenced by the accuracy to which the indentations can be measured.

10.5.2 The error in measuring the diagonals increases as the numerical aperture of the measuring objective decreases (3, 4).

10.5.3 Bias is introduced if the operator consistently under-sizes or oversizes the indentations.

10.6 Some of the factors that affect test results produce systematic errors that influence all test results while others primarily influence low-force test results (5). Some of these problems occur continually, others may occur in an undefined, sporadic manner. Low force hardness tests are influenced by these factors to a greater extent than high force tests.

10.7 For both the Vickers and Knoop hardness tests, the calculated microindentation hardness is a function of three variables: force, indenter geometry and diagonal measurement. Total differentials of the equations used to calculate the microindentation hardness can be used to evaluate the effect variations in these parameters can cause.

10.7.1 *Vickers*—using Eq 6, the total differential for the Vickers hardness number is:

$$dV = \left(\frac{\partial V}{\partial P}\right) dP + \left(\frac{\partial V}{\partial d}\right) dd + \left(\frac{\partial V}{\partial \alpha}\right) d\alpha \quad (10)$$

and

$$\left(\frac{\partial V}{\partial P}\right) = 2 \times 10^3 \times d^{-2} \times \sin\left(\frac{\alpha}{2}\right) \quad (11)$$

$$\left(\frac{\partial V}{\partial d}\right) = -4 \times 10^3 \times P \times d^{-3} \sin\left(\frac{\alpha}{2}\right) \quad (12)$$

$$\left(\frac{\partial V}{\partial \alpha}\right) = 10^3 \times P \times d^{-2} \cos\left(\frac{\alpha}{2}\right) \quad (13)$$

Thus, for a material having a hardness of 500 HV when tested with a 500 gf force,  $d = 43.06 \mu\text{m}$ ,  $\alpha = 136^\circ$ , and

$$\sin\left(\frac{\alpha}{2}\right) = 0.927184.$$

10.7.1.1 Consider introducing a 1% error into the hardness of the material through an error in either the applied force, the indenter constant or the measured diagonal length. In this case,

<sup>3</sup> The boldface numbers in parentheses refer to the list of references at the end of this standard.

the hardness would be  $HV' = 505$  or  $dV = 5$ . Using Eq 11-13, the corresponding errors in the various parameters are as shown in Table 1. Thus a 1 % change in  $P$  or a 2.09 % error in  $\alpha$  creates a 1 % error in the Vickers hardness number. However, only a 0.5 % error in the measured diagonal is needed to create a 1 % error in Vickers hardness. Furthermore, this analysis indicates that the calculated Vickers hardness number is not strongly influenced by errors in the angle of the indenter.

10.7.2 *Knoop*—Similarly, using Eq 1, it follows that:

$$dK = \left(\frac{\partial K}{\partial P}\right) dP + \left(\frac{\partial K}{\partial c_p}\right) dc_p + \left(\frac{\partial K}{\partial d}\right) dd \quad (14)$$

$$\frac{10^3}{c_p d^2} dP + \frac{10^3 P}{c_p^2 d^2} dc_p + \frac{-2 \times 10^3 P}{c_p d^3} dd \quad (15)$$

and since the indenter has two different angles, A and B,

$$dc_p = \left(\frac{\partial c_p}{\partial A}\right) dA + \left(\frac{\partial c_p}{\partial B}\right) dB \quad (16)$$

$$\left(\frac{\partial c_p}{\partial A}\right) = \frac{-\tan\left(\frac{\angle B}{2}\right)}{4 \sin^2\left(\frac{\angle A}{2}\right)} \quad (17)$$

and

$$\left(\frac{\partial c_p}{\partial B}\right) = \frac{\cot\left(\frac{\angle A}{2}\right)}{4 \cos^2\left(\frac{\angle B}{2}\right)} \quad (18)$$

10.7.2.1 Using the differentials cited in 10.7.2, for the Knoop test at various forces, for a 1 % error in hardness that is,  $KH' = 505$  or  $dK = 5$ , the corresponding errors in the force, diagonal measurement and indenter angle are as shown in Table 2. From this analysis it follows that 1 % error in  $P$  creates a 1 % error in HK, 0.5 % error in the measured diagonal creates a 1 % error in HK, and 1 % error in  $c$  creates a 1 % error in HK.

10.7.2.2 Since the indenter constant is composed of terms from two different angles, either a 4' 3" error in  $\angle A$ , or a 26' 20" error in  $\angle B$  produces a 1 % error in HK. Unlike the Vickers indenter, the calculated Knoop hardness number is very strongly influenced by small errors in the two angles of the indenter. The A angle, 172° 30' 00", is the most sensitive of these parameters. The actual value of  $c_p$  for each indenter can be calculated using the certified A and B angles provided by the indenter manufacturer. This will enhance the accuracy of the test measurements.

10.8 An interlaboratory test program was conducted in accordance with Practice E 691 to develop information regard-

TABLE 1 Vickers Hardness Analysis—1 % Error

Force, gf	Diagonal, $\mu\text{m}$	1 % Error		
		$\Delta P$ , gm	$\Delta$ Diagonal, $\mu\text{m}$	$\Delta$ Angle, °
10	6.090	0.100	-0.030	2.836
20	8.612	0.200	-0.043	2.836
50	13.617	0.499	-0.068	2.836
100	19.258	0.999	-0.096	2.836
200	27.235	1.998	-0.136	2.836
500	43.062	4.994	-0.215	2.836
1000	60.899	9.988	-0.304	2.836

2° 50' 24"

TABLE 2 Knoop Hardness Analysis—1 % Error

Force, gm	Diagonal, $\mu\text{m}$	1 % Error			
		$\Delta P$ gm	$\Delta$ diagonal, $\mu\text{m}$	$\Delta A$ , °	$\Delta B$ , °
10	16.87	0.10	-0.08	0.075	0.439
20	23.86	0.20	-0.12	0.075	0.439
50	37.72	0.50	-0.19	0.075	0.439
100	53.35	1.00	-0.27	0.075	0.439
200	75.45	2.00	-0.38	0.075	0.439
500	119.29	5.00	-0.60	0.075	0.439
1000	168.71	10.00	-0.84	0.075	0.439

4' 30" 26' 20"

ing the precision, repeatability, and reproducibility of the measurement of Knoop and Vickers indentations.<sup>4</sup> The test forces were 25, 50, 100, 200, 500, and 1000 gf on three ferrous and four nonferrous specimens (6, 7). Twelve laboratories measured the indentations, five of each type at each force on each sample. Additional details of this study are given in Appendix X3.

10.8.1 Tests of the three ferrous specimens revealed that nine laboratories produced similar measurements while two laboratories consistently undersized the indentations and one laboratory consistently oversized the indentations. These latter results were most pronounced as the force decreased and specimen hardness increased (that is, as the diagonal size decreased) and were observed for both Vickers and Knoop indentations. Results for the lower hardness nonferrous indentations produced better agreement. However, none of the laboratories that obtained higher or lower results on the ferrous specimens measured the nonferrous indentations.

10.8.2 *Repeatability Interval*—The difference due to test error between two test results in the same laboratory on the same material increases with increasing specimen hardness and with decreasing test force (see X3.4.4).

10.8.3 *Reproducibility Interval*—The difference in test results on the same material tested in different laboratories increased with increasing specimen hardness and with decreasing test force (see X3.4.5).

10.8.4 The within-laboratory and between-laboratory precision values improved as specimen hardness decreased and test force increased. The repeatability interval and reproducibility interval were generally larger than the precision estimate, particularly at low test forces and high specimen hardnesses.

10.8.5 *Image Analysis Measurements*—An interlaboratory test program was conducted in accordance with Practice E 691 to develop information regarding the repeatability and reproducibility of Knoop and Vickers measurements made with automated Image Analysis systems and manual procedures. Four ferrous specimens were used in the round robin. The test were conducted at 100 gf and 300 gf. The participants in the test program measured the same indentations on the four specimens. Seven labs measured the specimens using both procedures. The Knoop indentations on specimen C1 were too long for accurate measurements to be made by one lab; hence, only six sets of measurements were made on this specimen.

<sup>4</sup> Supporting data have been filed at ASTM Headquarters. Request RR:E04-1004.

Near the end of the test program, specimen B1 was lost in shipping; thus only six sets of measurements were made on this specimen. Additional details of the study are contained in [Appendix X4](#).

10.8.6 Repeatability concerns the variability between individual test results obtained within a single laboratory by a single operator with a specific set of test apparatus. For both the manual and automated measurements, the repeatability interval increased with specimen hardness and decreasing test force, [Appendix X4](#). For equivalent testing conditions, the repeatability interval for automated measurements was slightly larger than for manual measurements.

10.8.7 Reproducibility deals with the variability between single test results obtained by different laboratories applying the same test methods to the same or similar test specimens. For both the manual and automated measurements, the reproducibility interval increased with specimen hardness and decreasing test force, [Appendix X4](#). For equivalent testing conditions, the reproducibility interval for automated measurements was slightly larger than for manual measurements.

10.8.8 Practice [E 691](#) nor any other ASTM standard deals with comparing test results of a single property made by two

different test methods. Hence it is not possible to statistically and accurately compare the hardness measurements made by the manual and automated procedures. However, this information is graphically represented for comparative purposes, [X4.6](#).

**11. Conversion to Other Hardness Scales or Tensile Strength Values**

11.1 There is no generally accepted method for accurate conversion of Knoop or Vickers microindentation hardness numbers to other hardness scales or tensile strength values. Such conversions are limited in scope and should be used with caution, except for special cases where a reliable basis for the conversion has been obtained by comparison tests. For loads  $\geq 100$  gf microindentation Vickers hardness numbers are in reasonable agreement with macro Vickers hardness numbers. Refer to Test Method [E 140](#) for hardness conversion tables for metals.

**12. Keywords**

12.1 hardness; indentation; Knoop; microindentation; Vickers

**ANNEXES**

**(Mandatory Information)**

**A1. VERIFICATION OF KNOOP AND VICKERS HARDNESS TESTING MACHINES AND INDENTERS**

**A1.1 Scope**

A1.1.1 [Annex A1](#) specifies three types of procedures for verifying microindentation (Knoop and Vickers) hardness testing machines: direct verification, indirect verification, and weekly verification. This annex also contains geometric specifications for the indenter.

A1.1.2 Direct verification is a process for verifying that critical components of the hardness testing machine are within allowable tolerances by directly measuring the test forces, indentation measuring system, and testing cycle.

A1.1.3 Indirect verification is a process for periodically verifying the performance of the testing machine by means of standardized test blocks.

A1.1.4 The weekly verification is a process for monitoring the performance of the testing machine between indirect verifications by means of standardized test blocks.

**A1.2 General Requirements**

A1.2.1 The testing machine shall be verified at specific instances and at periodic intervals as specified in [Table A1.1](#), and when circumstances occur that may affect the performance of the testing machine.

A1.2.2 All instruments used to make measurements required by this Annex shall be calibrated traceable to national standards when a system of traceability exists, except as noted otherwise.

**TABLE A1.1 Verification Schedule for a Microindentation Hardness Testing Machine**

Verification Procedure	Schedule
Direct Verification	When a testing machine is new, or when adjustments, modifications or repairs are made that could affect the application of the test forces or the measuring system. Follow the manufacturers recommendations to determine when a direct verification is needed n a repaired, modified or adjusted instrument. When a testing machine fails an indirect verification.
Indirect Verification	Shall be no longer than every 18 months. Recommended every 12 months. Recommended when a test machine is installed or moved.
Weekly Verification	Required each week that the machine is used. Recommended whenever the indenter or test force is changed.

A1.2.3 Indirect verification of the testing machine shall be performed at the location where it will be used.

A1.2.4 Direct verification of newly manufactured or rebuilt testing machines may be performed at the place of manufacture, rebuild or the location of use.

NOTE A1.1—It is recommended that the calibration agency that is used to conduct the verifications of microindentation hardness testing machines be accredited to the requirements of ISO 17025 (or an equivalent) by a



recognized accrediting body that operates to the requirements of ISO Guide 58.

### A1.3 Direct Verification

A1.3.1 A direct verification of the testing machine shall be performed at specific instances in accordance with **Table A1.1**. The test forces, indentation measuring system and testing cycle shall be verified as follows.

NOTE A1.2—Direct verification is a useful tool for determining the sources of error in a microindentation hardness testing machine. It is recommended that testing machines undergo direct verification periodically to make certain that errors in one component of the machine are not being offset by errors in another component.

A1.3.2 *Verification of the Test Forces*—For each microindentation hardness scale that will be used, the corresponding test force shall be measured. The test forces shall be measured in accordance with ASTM E 4 by means of a Class A elastic force measuring instrument having an accuracy of at least 0.25 %, as described in ASTM E 74.

A1.3.2.1 Make three measurements of each force. The forces shall be measured as they are applied during testing; however, longer dwell times are allowed when necessary to enable the measuring device to obtain accurate measurements.

A1.3.2.2 Each test force *F* shall meet the requirements specified in **Table A1.2**.

A1.3.3 *Verification of the Indentation Measuring System*—The measuring device used to determine the diagonal of the indentation shall be verified at five evenly spaced intervals over the working range by comparison with an accurate scale such as a stage micrometer. The line interval accuracy of the stage micrometer shall be 0.1 micron or 0.05 %, which ever is greater. Throughout the range covered, the difference between the reading of the device and of the stage micrometer shall not exceed 0.4 microns or 0.5 %, which ever is greater.

A1.3.4 *Verification of the Testing Cycle*—The testing machine shall be verified to be capable of meeting the testing cycle tolerances specified in **6.1**. Direct verification of the testing cycle is to be verified by the testing machine manufacturer at the time of manufacture, or when the testing machine is returned to the manufacturer for repair, or when a problem with the testing cycle is suspected. Verification of the testing cycle is recommended but not required as part of the direct verification at other times.

NOTE A1.3—Instruments that have timing controlled by software or other nonadjustable components do not have to be verified providing that the design has been proven to produce the correct time cycles.

A1.3.5 *Verification of Indenter*—The geometry of the indenter is verified at time of manufacturing and it is mandatory for new machines. Subsequent verifications of the indenter are performed by visual inspection of the resulting indentation; it is sufficient to verify the absence of defects from the shape of indentations performed on test blocks. The indenter Geometry is specified as follows:

**TABLE A1.2 Accuracy of Applied Forces**

Applied Force, gf	Accuracy, %
P < 200	1.5
P ≥ 200	1.0

#### A1.3.5.1 Vickers Microindentation Indenter:

(1) The Vickers microindentation indenter for standard use, direct verification, and indirect verification shall have face angles of  $136^{\circ} 0' \pm 30'$ .

(2) The offset shall not exceed 0.5 μm.

(3) The four faces of the diamond shall be equally inclined to the axis of the indenter to within  $\pm 30'$ , as shown in **Fig. 2**. Vickers microindentation diamond indenters used for calibrating test blocks shall have face angles of  $136^{\circ} 0' \pm 6'$ .

(4) The  $136^{\circ}$  face angles may be verified by measuring the angles between the opposite edges. When measured, the edge angles shall be  $148^{\circ} 6' 36'' \pm 45'$  for standard use indenters and  $148^{\circ} 6' 36'' \pm 9'$  for indenters used for calibrating test blocks. For all indenters the edge angles shall be equally inclined to the axis of the indenter within  $\pm 30'$ .

NOTE A1.4—It is permissible to verify the offset by using a microscope with at least 500× magnification to view an indent created by the indenter and compare the offset length to a known dimension.

#### A1.3.5.2 Knoop Indenter:

(1) The ideal Knoop diamond indenter has an included longitudinal edge angle,  $\angle A = 172^{\circ} 30'$ , and included transverse edge angle,  $\angle B = 130^{\circ} 0'$ . The ideal indenter constant,  $c_p = 0.07028$ . For all indenters,  $c_p$  shall be within  $\pm 1\%$  of the ideal value,  $0.06958 \leq c_p \leq 0.07098$ .

(2) The tolerance of  $\angle A = 172^{\circ} 30'$ , shall be  $\pm 0.10^{\circ} (6')$ .

(3) The corresponding  $\angle B = 130^{\circ}$  must be contained within the dimensions listed in **Table A1.3** and graphically as described by **Fig. A1.1**.

(4) The offset shall not be more than 1 μm in length for indentations greater than 15 μm in length, as shown in **Fig. 1**. For shorter indentations the offset should be proportionally less.

(5) The four faces of the diamond shall be equally inclined to the axis of the indenter to within  $\pm 30'$ , as shown in **Fig. 1**.

(6) The device used to verify the indenter shall have a max. uncertainty of  $\pm 40$  minutes.

A1.3.6 *Direct Verification Failure*—If any of the direct verifications fail the specified requirements, the testing machine shall not be used until it is adjusted or repaired. If the test forces, indentation measuring system or testing cycle may have been affected by an adjustment or repair, the affected components shall be verified again by a direct verification.

### A1.4 Indirect Verification

A1.4.1 An indirect verification of the testing machine shall be performed in accordance with the schedule given in **Table A1.1**. Indirect verifications may be required more frequently than stated in **Table A1.1** and should be based on the usage of the testing machine.

A1.4.2 The testing machine shall be verified for each test force and for each indenter that will be used prior to the next

**TABLE A1.3 Angular Tolerances for Knoop Indenters**

A Angle, °	B Angle, °	
	Minimum	Maximum
172.4	128.97	129.85
172.6	130.15	131.02

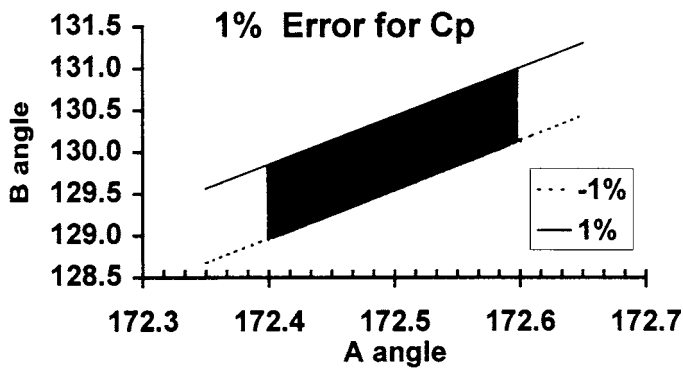

FIG. A1.1 Schematic Representing the Acceptable Regions of Knoop Indenter Angles

indirect verification. Hardness tests made using microindentation hardness scales that have not been verified within the schedule given in Table A1.1 do not meet this standard.

A1.4.3 Standardized test blocks used for the indirect verification shall meet the requirements of Annex A2.

NOTE A1.5—It is recognized that appropriate standardized test blocks are not available for all geometric shapes, materials, or hardness ranges.

A1.4.4 The indenter(s) to be used for the indirect verification shall meet the requirements of A1.3.5.

A1.4.5 *As-found Condition*—It is recommended that the as-found condition of the testing machine be assessed as part of an indirect verification. This is important for documenting the historical performance of the machine. This procedure should be conducted by the verification agency prior to any cleaning, maintenance, adjustments, or repairs.

A1.4.5.1 The as-found condition of the testing machine shall be determined with the user’s indenter that is normally used with the testing machine. One or more standardized test blocks in the range of normal testing should be used for each microindentation hardness scale that will undergo indirect verification.

A1.4.5.2 On each standardized test block, make at least three measurements distributed uniformly over the test surface. Let  $d_1, d_2, \dots, d_n$  be the indentation diagonal measurement values, and  $\bar{d}$  be the average of the measurements.

NOTE A1.6—When testing at low forces it may be necessary to increase the number of tests in order to obtain more consistent results.

A1.4.5.3 Determine the repeatability  $R$  and the error  $E$  in the performance of the testing machine for each standardized test block that is measured using Eq A1.1 and Eq A1.3 in section A1.7.

A1.4.5.4 The repeatability  $R$  and the error  $E$  should be within the tolerances of Table A1.5.

TABLE A1.4 Hardness Ranges Used for Indirect Verification

Range	Knoop	Vickers
Low	< 250	< 240
Medium	250–650	240–600
High	> 650	> 600

A1.4.5.5 If the calculated values of the repeatability  $R$  or the error  $E$  fall outside the specified tolerances, this is an indication that the hardness tests made since the last indirect verification may be suspect.

A1.4.6 *Cleaning and Maintenance*—Perform cleaning and routine maintenance of the testing machine when required in accordance with the manufacturer’s specifications and instructions.

A1.4.7 *Indirect Verification Procedure*—The indirect verification procedure is designed to verify that for all of the microindentation hardness scales to be used, each test force is being accurately applied, each indenter is correct, and the measuring device is calibrated correctly for the range of indentation sizes that these scales produce. This is accomplished by making microindentation hardness measurements on test blocks that have been calibrated for appropriate microindentation hardness scales that employ each of the corresponding test forces.

A1.4.7.1 The testing machine shall be verified with the user’s indenter(s) normally used for testing.

A1.4.7.2 A minimum of two standardized test blocks shall be used for the verification of the testing machine. The hardness values and microindentation hardness scales of the test blocks shall be chosen such that the following criteria are met:

A1.4.7.3 Each test force will be used.

A1.4.7.4 At least one microindentation hardness test block calibrated according to Annex A2, shall be used for each scale to be verified.

A1.4.7.5 At least two of the blocks shall be from different hardness ranges, low, mid or high hardness as specified in Table A1.4. The hardness difference between the two blocks used for verification shall be a minimum of 100 points. For example, if a Knoop block having a hardness of 240 is used to verify the low scale, then a Knoop block having a minimum hardness of 340 shall be used to verify the medium hardness scale.

A1.4.7.6 The highest test force shall be verified on a block from the lower of the chosen hardness ranges to produce the largest indentation size, and the lowest test force shall be used on the block from the higher of the chosen hardness ranges to produce the smallest indentation size. The two extremes of indentation size will verify the capability of the measuring device.

*Example 1*—A testing machine is to be verified for the HV0.5 and HK1 scales. Two test blocks are chosen for the verification: 450 HV0.5 (mid-range) and HK1 (low-range). In this case, both of the test forces are verified by using only two blocks. The highest test force (1000 gf) is used on a low-range hardness block, and the lowest test force (500 gf) is used on a mid-range test block, which is the higher of the two hardness ranges.

*Example 2*—A testing machine is to be verified for the HK0.1, HV 0.3 and HV1 scales. Three test blocks are chosen for the verification: 720 HK0.1 (high-range), 480 HV0.3 (mid-range) and 180 HV1 (low-range). In this case, there are three test forces that must be verified. The highest test force (1000 gf) is used on a low-range hardness block, and the lowest

**TABLE A1.5 Repeatability of Test Machines—Indirect Verification by Standardized Test Blocks Based on Measured Diagonal Lengths<sup>A</sup>**

Hardness Range of Standardized Test Blocks		Force, gf	<i>R</i> Maximum Repeatability (%)	<i>E</i> Maximum Error (%)
Knoop	Vickers			
HK > 0	HV > 0	1 ≤ P < 100	13	3
HK < 100	HV < 100	100 ≤ P ≤ 1000	13	3
100 ≤ HK ≤ 250	100 ≤ HV ≤ 240	100 ≤ P < 500	13	2
250 < HK ≤ 650	240 < HV ≤ 600		5	2
HK > 650	HV > 600		4	2
100 ≤ HK ≤ 250	100 ≤ HV ≤ 240	500 ≤ P ≤ 1000	8	2
250 < HK ≤ 650	240 < HV ≤ 600		4	2
HK > 650	HV > 600		3	2

<sup>A</sup> In all cases, the repeatability is the greater of the percentage given or 1 μm; the maximum error is the greater of the value obtained or 0.5 μm.

test force (100 gf) scale is used on the high-range test block. The middle test force (300 gf) scale could be used on either a low-range or mid-range test block.

A1.4.7.7 On each standardized test block, make five measurements distributed uniformly over the test surface. Let  $d_1$ ,  $d_2$ , ...,  $d_5$  be the five indentation diagonal measurement values, and  $\bar{d}$  be the average of the five measurements. Determine the repeatability  $R$  and the error  $E$  in the performance of the testing machine using Eq A1.1 and Eq A1.3 in section A1.7, for each hardness level of each microindentation hardness scale to be verified. The repeatability  $R$  and the error  $E$  shall be within the tolerances of Table A1.5.

A1.4.7.8 If the measurements of error  $E$  or repeatability  $R$  using the user's indenter fall outside of the specified tolerances, the indirect verification measurements may be repeated using a different indenter.

A1.4.7.9 The indirect verification shall be approved only when the testing machine measurements of repeatability and error meet the specified tolerances with the user's indenter.

A1.4.8 In cases where it is necessary to replace the indenter during the period between indirect verifications, the new indenter must be verified for use with the specific testing machine. The user shall perform the verification by following the as-found procedures given in A1.4.5. If the repeatability,  $R$ , and error,  $E$ , values fall within the tolerances in Table A1.5 the indenter can be used.

A1.4.9 When the combination of block hardness and test force produces indentations with diagonals less than 20 μm long, indirect verification using standardized test blocks is not recommended. In these situations, the indentation measurement error represents a significant proportion of the diagonal length. This can lead to substantial deviations in hardness from the stated value. Examples of these errors are contained in Section 10 and Tables 1 and 2.

## A1.5 Weekly Verification

A1.5.1 The weekly verification is intended as a tool for the user to monitor the performance of the testing machine between indirect verifications. At a minimum, the weekly verification shall be performed in accordance with the schedule given in Table A1.1 for each microindentation hardness scale

that will be used. It is strongly recommended that this verification should be performed on a daily basis.

A1.5.2 It is recommended that the weekly verification procedures be performed whenever the indenter or test force is changed.

A1.5.3 *Weekly Verification Procedures*—The procedures to use when performing a weekly verification are as follows.

A1.5.3.1 At least one standardized test block that meets the requirements of Annex A2 shall be used for each microindentation hardness scale to be used. When test blocks are commercially available, the hardness level of the test blocks shall be chosen at approximately the same hardness value as the material to be measured.

A1.5.3.2 The indenter to be used for the weekly verification shall be the indenter that is normally used for testing.

A1.5.3.3 Before performing the weekly verification tests, ensure that the testing machine is working freely, the stage and test block are clean, and the measuring device is properly adjusted and zeroed.

A1.5.3.4 Make at least three hardness measurements on each of the verification test blocks. The tests shall be distributed uniformly over the surface of the test blocks.

A1.5.3.5 Let  $\bar{d}$  be the average of the measurements. Determine the error  $E$  in the performance of the testing machine using Eq A1.3 for each standardized test block that is measured.

A1.5.3.6 If the error  $E$  calculated for each test block is within the tolerances given in Table A1.5, the testing machine with the indenter may be regarded as performing satisfactorily.

A1.5.3.7 If the error  $E$  calculated for any of the test blocks is outside the tolerances, the weekly verification may be repeated with a different indenter. If the average of the hardness measurements again falls outside of tolerances for any of the test blocks, an indirect verification shall be performed.

A1.5.3.8 Whenever a testing machine fails a weekly verification, the hardness tests made since the last valid weekly verification may be suspect.

NOTE A1.7—It is highly recommended that the results obtained from the weekly verification testing be recorded using accepted Statistical