



SLOVENSKI STANDARD
SIST ISO 11001-1:2016

01-maj-2016

Nadomešča:
SIST ISO 11001-1:1995

Kmetijski traktorji - Tritočkovni priključni spoji - 1. del: U-priključni okvir

Agricultural wheeled tractors - Three-point hitch couplers - Part 1: U-frame coupler

iTeh STANDARD PREVIEW
(standards.iteh.ai)
Tracteurs agricoles à roues - Coupleurs rapides trois points - Partie 1: Coupleur par cadre en U

Ta slovenski standard je istoveten z: [SIST ISO 11001-1:2016](https://standards.iteh.ai/catalog/standards/sist/11001-1-2016/iso-11001-1-2016) **ISO 11001-1:2016**
https://standards.iteh.ai/catalog/standards/sist/11001-1-2016/iso-11001-1-2016

ICS:

65.060.01	Kmetijski stroji in oprema na splošno	Agricultural machines and equipment in general
-----------	---------------------------------------	--

SIST ISO 11001-1:2016

en,fr

iTeh STANDARD PREVIEW
(standards.iteh.ai)

[SIST ISO 11001-1:2016](#)

<https://standards.iteh.ai/catalog/standards/sist/d860ffe0-4961-498b-bdfa-970d80f92bcf/sist-iso-11001-1-2016>

INTERNATIONAL
STANDARD

ISO
11001-1

Second edition
2016-02-15

**Agricultural wheeled tractors —
Three-point hitch couplers —**

**Part 1:
U-frame coupler**

Tracteurs agricoles à roues — Coupleurs rapides trois points —

Partie 1: Coupleur par cadre en U

iTeh STANDARD PREVIEW
(standards.iteh.ai)

SIST ISO 11001-1:2016

<https://standards.iteh.ai/catalog/standards/sist/d860ff0-4961-498b-bdfa-970d80f92bcf/sist-iso-11001-1-2016>



Reference number
ISO 11001-1:2016(E)

© ISO 2016

iTeh STANDARD PREVIEW
(standards.iteh.ai)

SIST ISO 11001-1:2016

<https://standards.iteh.ai/catalog/standards/sist/d860ff0-4961-498b-bdfa-970d80f92bcf/sist-iso-11001-1-2016>



COPYRIGHT PROTECTED DOCUMENT

© ISO 2016, Published in Switzerland

All rights reserved. Unless otherwise specified, no part of this publication may be reproduced or utilized otherwise in any form or by any means, electronic or mechanical, including photocopying, or posting on the internet or an intranet, without prior written permission. Permission can be requested from either ISO at the address below or ISO's member body in the country of the requester.

ISO copyright office
Ch. de Blandonnet 8 • CP 401
CH-1214 Vernier, Geneva, Switzerland
Tel. +41 22 749 01 11
Fax +41 22 749 09 47
copyright@iso.org
www.iso.org

Contents

	Page
Foreword	iv
1 Scope	1
2 Normative references	1
3 Principle of frame coupler system	1
4 Coupler dimensions	1
5 Dimensions associated with implement	5
6 Requirements	6

iTeh STANDARD PREVIEW (standards.iteh.ai)

[SIST ISO 11001-1:2016](https://standards.iteh.ai/catalog/standards/sist/d860ff0-4961-498b-bdfa-970d80f92bcf/sist-iso-11001-1-2016)

<https://standards.iteh.ai/catalog/standards/sist/d860ff0-4961-498b-bdfa-970d80f92bcf/sist-iso-11001-1-2016>

ISO 11001-1:2016(E)

Foreword

ISO (the International Organization for Standardization) is a worldwide federation of national standards bodies (ISO member bodies). The work of preparing International Standards is normally carried out through ISO technical committees. Each member body interested in a subject for which a technical committee has been established has the right to be represented on that committee. International organizations, governmental and non-governmental, in liaison with ISO, also take part in the work. ISO collaborates closely with the International Electrotechnical Commission (IEC) on all matters of electrotechnical standardization.

The procedures used to develop this document and those intended for its further maintenance are described in the ISO/IEC Directives, Part 1. In particular the different approval criteria needed for the different types of ISO documents should be noted. This document was drafted in accordance with the editorial rules of the ISO/IEC Directives, Part 2 (see www.iso.org/directives).

Attention is drawn to the possibility that some of the elements of this document may be the subject of patent rights. ISO shall not be held responsible for identifying any or all such patent rights. Details of any patent rights identified during the development of the document will be in the Introduction and/or on the ISO list of patent declarations received (see www.iso.org/patents).

Any trade name used in this document is information given for the convenience of users and does not constitute an endorsement.

For an explanation on the meaning of ISO specific terms and expressions related to conformity assessment, as well as information about ISO's adherence to the WTO principles in the Technical Barriers to Trade (TBT) see the following URL: [Foreword - Supplementary information](#).

The committee responsible for this document is ISO/TC 23, *Tractors and machinery for agriculture and forestry*, Subcommittee SC 4, *Tractors*.

This second edition cancels and replaces the first edition (ISO 11001-1:1993), which has been technically revised.

ISO 11001 consists of the following parts, under the general title *Agricultural wheeled tractors — Three-point hitch couplers*:

- *Part 1: U-frame coupler*
- *Part 2: A-frame coupler*
- *Part 3: Link coupler*
- *Part 4: Bar coupler*

Agricultural wheeled tractors — Three-point hitch couplers —

Part 1: U-frame coupler

1 Scope

This part of ISO 11001 specifies the essential dimensions for the attachment of three-point hitch implements to agricultural wheeled and track-laying tractors equipped with a three-point free link hitch according to ISO 730 or ISO 8759-1 and a U-frame hitch coupler.

NOTE In general the dimensions associated with the tractor and implement for use with hitch couplers are the same as those for the three-point linkage specified in ISO 730 or ISO 8759-1, and those for the clearance zone specified in ISO 2332.

The three-point hitch coupler systems constitute a special method of implement mounting. The hitch couplers are an additional component located between the three-point linkage and the implement, making it possible to hitch and unhitch from the operator's seat. Due to the special construction and function of hitch couplers, it can be necessary to vary the length of the upper and lower links indicated in the referenced standards.

This part of ISO 11001 applies to categories 1, 2N, 2, 3N, 3, 4N, and 4 of agricultural wheeled and track-laying tractors as defined in ISO 730 or ISO 8759-1.

<https://standards.iteh.ai/catalog/standards/sist/d860ff0-4961-498b-bdfa-970d80f92bcf/sist-iso-11001-1-2016>

2 Normative references

The following documents, in whole or in part, are normatively referenced in this document and are indispensable for its application. For dated references, only the edition cited applies. For undated references, the latest edition of the referenced document (including any amendments) applies.

ISO 730, *Agricultural wheeled tractors — Rear-mounted three-point linkage — Categories 1N, 1, 2N, 2, 3N, 3, 4N and 4*

ISO 2332:2009, *Agricultural tractors and machinery — Connection of implements via three-point linkage — Clearance zone around implement*

ISO 8759-1, *Agricultural wheeled tractors — Front-mounted equipment — Part 1: Power take-off and three-point linkage*

3 Principle of frame coupler system

A frame coupler system is a one-phase implement coupler where the three-point linkage of the tractor (see ISO 730 or ISO 8759-1) is fitted with a U-frame and the implement has the provisions to be mounted to the frame. Hitching and unhitching can be operated from the tractor operator's seat.

4 Coupler dimensions

Coupler dimensions shall comply with [Figure 1](#) and [Table 1](#).

4.1 The upper hook offset (dimension B_5) shall be not more than 15,75 mm greater or 6,35 mm less than the lower socket offset (dimension B_1).

ISO 11001-1:2016(E)

4.2 The implement shall provide a minimum clearance h_3 , (see [Figure 2](#) and [Table 2](#)) when attached to the coupler to permit lowering all elements of the coupler to ensure satisfactory attachment and detachment of the implement from the coupler.

NOTE Older legacy implements may only have clearances of 120,9 mm for categories 1, 2N, 2, 3N, and 3, and 146 mm minimum for categories 4N and 4.

4.3 The upper hook of the quick coupler shall be centred between the lower sockets within 3 mm.

4.4 The lower implement attaching point on the quick-attaching coupler shall be located in the vertical position such that the lift range, power range and levelling adjustment, as specified in ISO 730 or ISO 8759-1 are fulfilled.

4.5 Implement components, other than the hitch pins, that are in alignment with the lower socket width (dimension A_1) shall not extend forward of the centreline of the lower socket for a distance of h_5 (see [Figure 2](#) and [Table 2](#)) above the lower socket. Components above this height, extending laterally more than l_3 (see [Figure 2](#) and [Table 2](#)) from the coupler centreline, shall not extend more than 25 mm forward of the vertical centreline through the upper hook opening.

4.6 The lower socket width (A_1) shall be maintained within the area defined by dimensions B_2 , H_6 , H_7 and B_9 .

4.7 The lower link to coupler pins may be recessed to provide design freedom to obtain structural integrity in the coupler frame, resulting in a common dimension for L_3 and L_6 , and L_4 and L_7 , respectively.

4.8 Note that ISO 730 specifies that dimension L in [Table 2](#) shall have a range of 75 mm for hitch categories 1, 2N, and 2 and a range of 100 mm for hitch categories 3N, 3, 4N, and 4. Dimension B_1 in this part of ISO 11001 allows the lower socket offset to be larger than the range allowed in ISO 730. For tractors designed with U-frame couplers as standard equipment, the lower links should be shortened so that the distance to the lower U-frame coupler jaw falls within the range for dimension L specified in ISO 730. For tractors that offer U-frame couplers as an option, the lower links should be designed to the minimum L dimension given in ISO 730 as far as possible to minimize the distance that the combined lower link and U-frame coupler length is over the upper limit of the L dimension given in ISO 730.

4.9 For U-frame couplers that by design can be converted to different hitch categories, dimensions H_6 , H_7 , H_5 , L_4 , L_2 , L_5 and L_3 may not be achieved in all configurations.

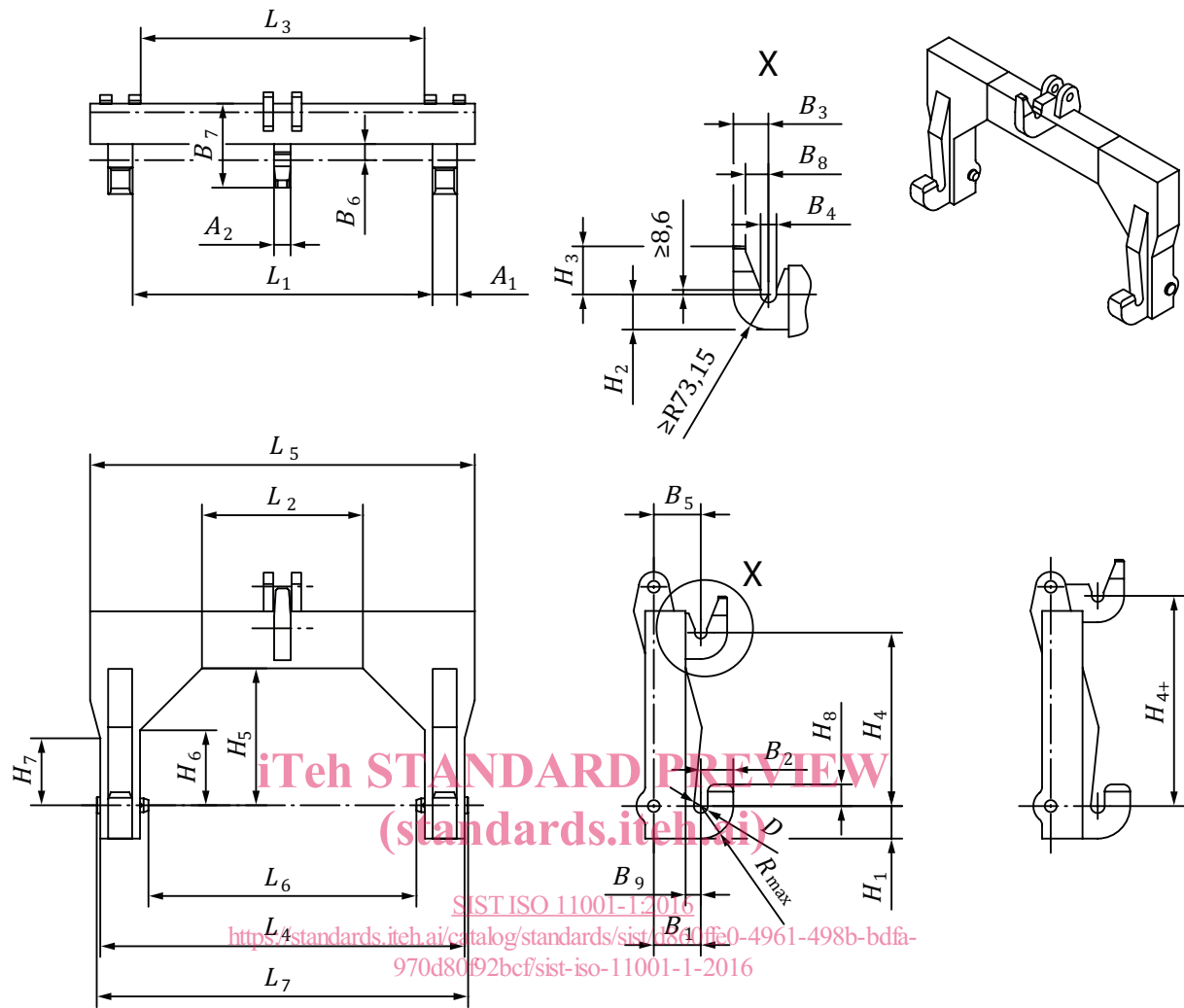

Figure 1 — Coupler dimensions

Table 1 — Coupler dimensions

Dimensions in millimetres

Dimen- sions	Designa- tion	Category													
		1		2N		2		3N		3		4N		4	
		min	max	min	max	min	max	min	max	min	max	min	max	min	max
L_1	Lower socket inside span	686	690	686	690	828	834	828	834	970	975	925	930	1 170	1 175
A_1	Lower socket width	28	30	63	67	63	67	63	67	63	67	86	89	86	89
B_1	Lower socket offset	—	104	—	130	—	130	—	130	—	130	—	165	—	165
D	Lower socket diameter	38,1	38,6	38,1	38,6	38,1	38,6	38,1	38,6	38,1	38,6	52	52,5	52	52,5
B_2	Lower socket overhang	—	90	—	90	—	90	—	90	—	90	—	130	—	130
H_1	Lower socket depth	—	90	—	90	—	90	—	90	—	90	—	130	—	130