



Designation: D 4965 – 96

Standard Terminology of Seams and Seam Finishes Used in Home Sewing¹

This standard is issued under the fixed designation D 4965; the number immediately following the designation indicates the year of original adoption or, in the case of revision, the year of last revision. A number in parentheses indicates the year of last reapproval. A superscript epsilon (ϵ) indicates an editorial change since the last revision or reapproval.

1. Scope

1.1 This terminology provides a uniform, easily understood language for the definitions and descriptions of seams and seam finishes used in home sewing.

1.1.1 These seams and seam finishes may be produced on a conventional sewing machine or by hand.

1.1.2 These terms and definitions are not necessarily applicable to the apparel manufacturing industry.

1.2 This terminology provides a common base for use in the preparation of educational materials and pattern guide sheets for home sewing.

1.3 Other seam types or finishes may be more appropriate if equipment other than the conventional sewing machine is available.

1.4 For other terms associated with textiles, refer to Terminology D 123.

2. Referenced Documents

2.1 *ASTM Standards:*

D 123 Terminology Relating to Textile Materials²

D 1353 Terminology of Basic Sewing Machine Stitches²

3. Terminology

3.1 *Definitions:*

back side, *n*—in textile materials, the side of the material that faces innermost in the completed product. (Ant. **face side, right side**. Syn. *wrong side*.)

bound seam-finish, *n*—in home sewing, a seam finish in which another material is used to enclose the cut edges of one or more seam allowances. (Compare **Hong Kong seam finish**.) (See Fig. 1.)

DISCUSSION—A bound seam-finish is made by (1) enclosing the cut seam allowance edge(s) in another fabric and (2) machine stitching through all thicknesses close to the edge of the binding. Material used may be strips of lightweight bias-cut woven fabric or lightweight knit fabric such as tricot or net. If tape or binding is used, the wider fold side of the tape or binding is positioned underneath the seam allowance. Usually each seam allowance edge is enclosed individually; however, seam allowances may be placed together and treated as one, such as the

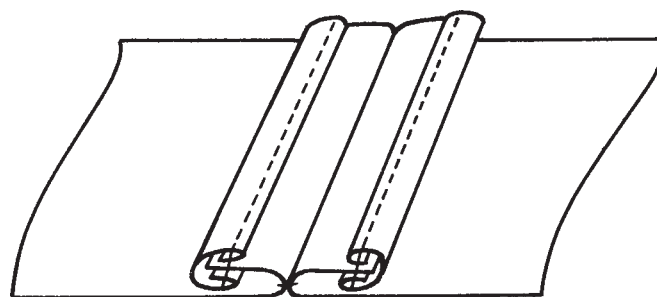

FIG. 1 Bound Seam Finish from Back Side of Fabric

armseye seam allowances of an unlined jacket or on a bound neckline.

clean-finish seam finish, *n*—in home sewing, a seam finish in which the cut edge is folded under and the fold line is edge stitched. (See Fig. 2.) (Syn. **turned and stitched seam finish**.)

DISCUSSION—A clean-finish seam finish is made by (1) turning under each cut edge of a plain seam allowance approximately 3 to 6 mm ($\frac{1}{8}$ to $\frac{1}{4}$ in.) and (2) stitching close to the folded edge. A stabilizing line of stitching 3 to 6 mm from a curved cut edge will facilitate turning before stitching close to the fold.

complex seam, *n*—in home sewing, a seam made in two or more steps. (Ant. **plain seam**.)

DISCUSSION—Complex seams have one or more stitching lines as part of their construction and include double-welt seams, flat-felled seams, French seams, lapped seams, mock French seams, slot seams, tucked seams, and welt seams. They do not include plain seams or seam finishes or decorative additions to seams.

double-welt seam, *n*—in home sewing, a complex seam formed on the inside of the product, in which one trimmed seam allowance is enclosed and two rows of stitching are visible on the face side. (Compare **welt seam**. Syn. *mock flat-felled seam*.) (See Fig. 3.)

DISCUSSION—A double-welt seam is made like a welt seam except that it has a second row of topstitching close to the original seamline. The three rows of stitching visible on the back side are the original seam line, the row of stitching through the outermost layer of the sewn product and the wider of the seam allowances, and the row added near the original seam line.

edge-stitched seam finish, *n*—in home sewing, a seam finish in which machine stitching is placed close to the cut edge of each seam allowance. (Compare **zigzagged seam finish**.) (See Fig. 4.)

¹ This terminology is under the jurisdiction of ASTM Committee D-13 on Textiles and is the direct responsibility of Subcommittee D13.53 on Practices.

Current edition approved Nov. 10, 1995 and February 10, 1996. Published July 1996. Originally published as D 4965 – 89a. Last previous edition D 4965 – 95.

² *Annual Book of ASTM Standards*, Vol 07.01.

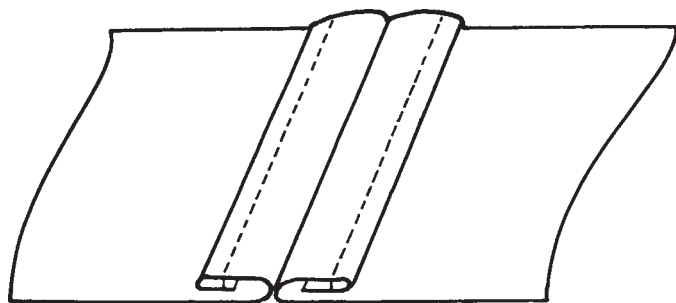

FIG. 2 Clean-Finish Seam Finish from Back Side of Fabric

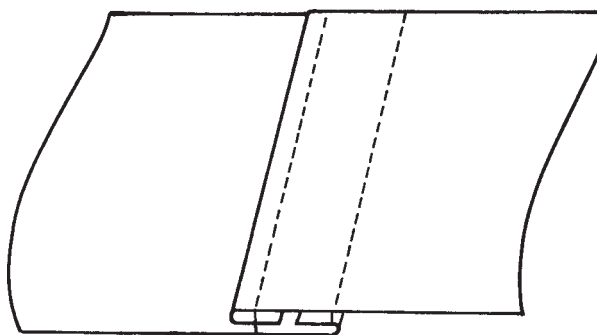

FIG. 5 Flat-Felled Seam from Face Side of Fabric

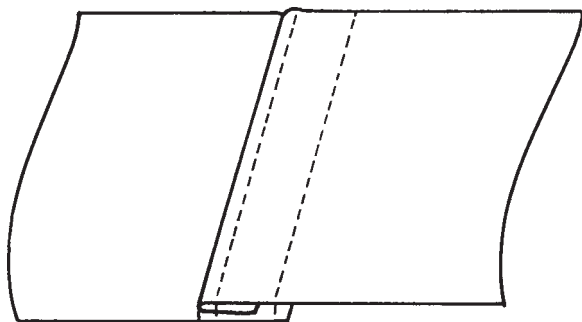

FIG. 3 Double-Welt Seam from Face Side of Fabric

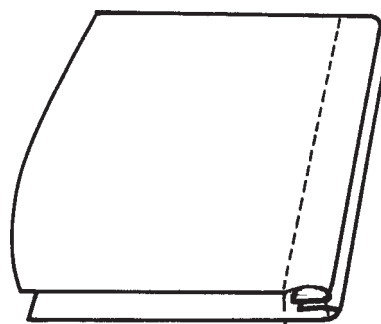

FIG. 6 French Seam from Back Side of Fabric

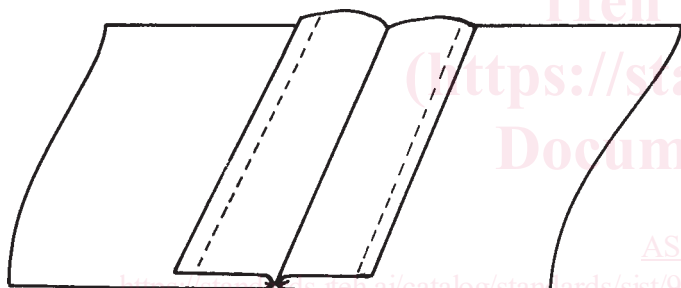

FIG. 4 Edge-Stitched Seam Finish from Back Side of Fabric

DISCUSSION—An edge-stitched seam finish is made by straight stitching approximately 3 to 6 mm ($\frac{1}{8}$ to $\frac{1}{4}$ in.) from each cut edge of each seam allowance.

face side, n—in textile materials, the side of the material that is outermost in the completed product. (Ant. **back side**, *wrong side*. Syn. *right side*.)

flat-felled seam, n—in home sewing, a complex seam formed on the outside of a product with cut edges enclosed and two rows of machine stitching visible from the face side. (See Fig. 5(a) and (b).)

DISCUSSION—A flat-felled seam is made by (1) stitching a basic seam with the back sides together, (2) pressing both seam allowances to one side, (3) trimming the under seam allowance to approximately $\frac{1}{8}$ in. (3 mm), (4) turning under the cut edge of the upper seam allowance, and (5) topstitching close to the fold.

French seam, n—in home sewing, a complex seam formed on the inside of a product with both cut edges enclosed and no stitching rows visible on the face side. (Compare **mock French seam**.) (See Fig. 6.)

DISCUSSION—A French seam is made by (1) placing two sections of fabric with back sides together, (2) stitching a seam line 10 mm ($\frac{3}{8}$ in.)

from the cut edges, (3) pressing the seam open, (4) trimming the seam allowance to 3 mm ($\frac{1}{8}$ in.) if the fabric does not ravel easily, or to slightly less than 6 mm ($\frac{1}{4}$ in.) if the fabric ravel easily, (5) clipping or notching the curved seam allowances such that they respectively will fit the larger or smaller area, against which they will be pressed, (6) folding the face sides of the fabric together, (7) pressing again with the stitched seamline exactly on the folded edge, and (8) stitching 6 mm from the folded edge. By using this procedure, the cut edges of the trimmed seam allowance are enclosed completely. The two seam allowances make a total of 15 mm ($\frac{5}{8}$ in.), the standard seam allowance width. No stitching lines are visible from the face side. French seams are more appropriate for straight seams than curved seams.

glued seam, n—in home sewing, a seam formed by the use of an adhesive. (Compare **sewn seam**, **stapled seam**, **thermally bonded seam**.)

DISCUSSION—Adhesive may be glue, heat-fusible web or powder, or hot glue.

hand-overcast seam finish, n—in home sewing, a seam finish in which hand stitches are sewn such that the thread wraps around the cut edges of each seam allowance. (See Fig. 7.)

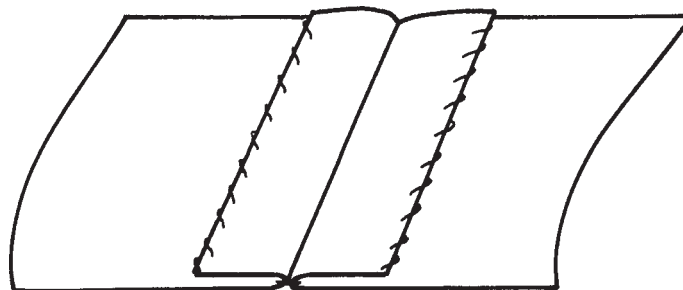

FIG. 7 Hand-Overcast Seam Finish from Back Side of Fabric

DISCUSSION—A hand-overcase seam finish is made by using a needle and thread to form stitches that are approximately 6 mm (¼ in.) apart and 3 to 6 mm (⅛ to ¼ in.) inside the cut edges of the seam allowance. The cut edge of each seam allowance is wrapped by the thread that passes over the edge.

Hong Kong seam finish, *n*—in home sewing, a seam finish in which a binding fabric is used to encase the cut edge of each seam allowance separately and in which the binding fabric has one cut edge enclosed and the other cut edge exposed. (Compare **bound seam finish**.) (See Fig. 8.)

DISCUSSION—A Hong Kong seam finish is made by (1) selecting a strip of light weight bias-cut woven fabric, lightweight knit such as tricot or tulle, or commercial bias tape pressed open (25 mm (1 in.) wide), (2) placing the bias strip against a seam allowance, face sides together and cut edges even, (3) stitching 6 mm (¼ in.) from the cut edges, (4) pressing the binding away from the seam and over the cut edge toward the underside of the seam allowance, and (6) stitching in the previously formed stitching line on the face side of the seam allowance, thus securing the under layer of the folded binding to the under side of the seam allowance (sometimes called “stitch-in-the-ditch”). The excess binding fabric may be trimmed close to the stitching.

inside seam, *n*—in home sewing, a seam having seam allowances located within the interior, or the underside, of the product. (Compare **outside seam**.)

DISCUSSION—Examples of inside seams include double-welt seams, French seams, lapped seams, mock French seams, slot seams, tucked seams, and welt seams.

joining line, *n*—See **seam**.

lapped seam,— except the topstitching is farther from the fold than that of a lapped seam 6 to 10 mm (¼ to ⅜ in.).

turned and stitched seam finish, *n*—See **clean finished seam finish**.

lapped seam for leather or nonwoven material, *n*—in home sewing, a complex seam formed on the outside of the product, with neither cut edge enclosed and having one or two rows of stitching and a cut edge visible from the outside. (Compare **lapped seam for woven or knitted fabric**.) (See Fig. 9(a) and (d).)

DISCUSSION—A lapped seam for leather or nonwoven fabric is made by (1) marking the corresponding seamlines on both pieces, (2) trimming off the entire seam allowance (15 mm (⅝ in.)) on the overlap or top section, (3) lapping the cut edge of the trimmed overlap section over the bottom section, butting the cut edge to the marked seamline beneath, and (4) gluing in place and topstitching with one or two rows of stitching. Both gluing and topstitching may be used. This seam is used on leather, nonwoven leather-like material, and vinyl where an exposed cut edge is not a concern.

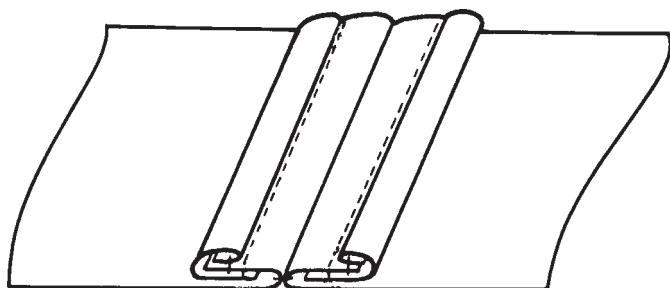

FIG. 8 Hong Kong Seam Finish from Back Side of Fabric

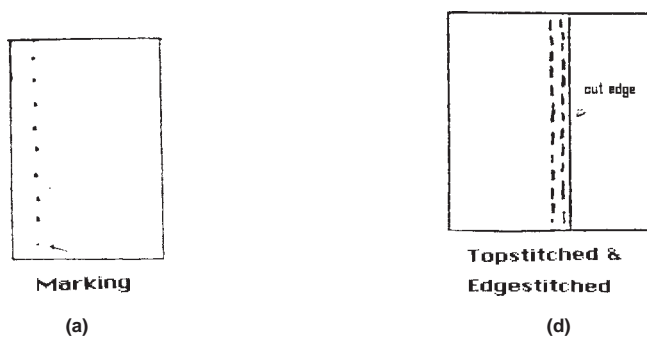

FIG. 9 Lapped Seam for Leather or Nonwoven Fabric from Face Side of Material

lapped seam for woven or knitted fabric, *n*—in home sewing, a complex seam formed on the inside of the product with neither raw cut edge enclosed, and having one visible line of topstitching on the face side and a small fold formed by the topstitching. (Compare **tucked seam**.) (See Fig. 10.)

DISCUSSION—A lapped seam for woven or knitted fabric is made by (1) folding under the seam allowance of the overlapping section along the 15-mm (⅝-in.) seamline and pressing, then (2) working from the right side and pinning the folded edge over the underlap section with the fold along the seamline, and (3) stitching close to the fold through all layers. Basting before stitching may be needed.

material, *n*—in home sewing, a planar structure such as textile fabric, plastic film, or leather.

DISCUSSION—“Materials” used may include fabric, fur, leather and plastic film. Joining methods for seams may vary.

mock flat-felled seam, *n*—See **double-welt seam**.

mock French seam, *n*—in home sewing, a complex seam formed on the inside of the product with cut edges enclosed and no stitching visible on the face side; similar in appearance to the French seam but constructed differently. (Compare **French seam**.) (See Fig. 11.)

DISCUSSION—A mock French seam is made by (1) placing two pieces of fabric with face sides together, (2) stitching on the 15-mm (⅝-in.) seamline, (3) trimming both seam allowances to 12 mm (½ in.), (4) clipping or notching, as appropriate, 3 mm (⅛ in.) on any curved edges so that curved seam allowances can fit the area against which they are folded and pressed, (5) pressing open the seam, (6) then folding and pressing each of the seam allowances 6 mm (¼ in.) toward the other and the seamline, bringing the folded edges together, and (7) stitching the two seam allowances together 1.5 mm (⅛ in.) from the folded edges. Mock French seams are more appropriate for curved areas than French seams.

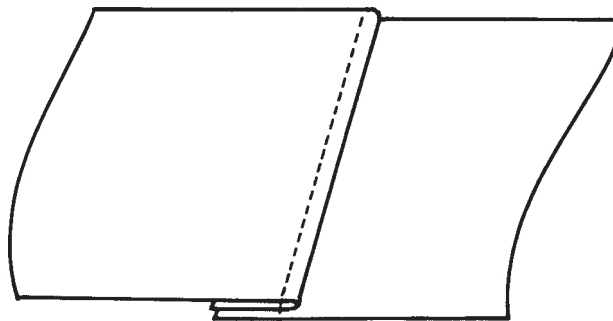

FIG. 10 Lapped Seam for Woven or Knitted Fabric from Face Side of Fabric