



Designation: D3908 – 03(Reapproved 2008)

Standard Test Method for Hydrogen Chemisorption on Supported Platinum Catalysts by Volumetric Vacuum Method¹

This standard is issued under the fixed designation D3908; the number immediately following the designation indicates the year of original adoption or, in the case of revision, the year of last revision. A number in parentheses indicates the year of last reapproval. A superscript epsilon (ϵ) indicates an editorial change since the last revision or reapproval.

1. Scope

1.1 This test method covers the determination of the chemisorption of hydrogen at 298 K (25°C) on supported platinum catalysts that have been reduced in flowing hydrogen at 723 K (450°C). It incorporates a static volumetric vacuum technique at constant volume.

1.2 The test method is intended for use on unused supported platinum on alumina catalysts of loadings greater than 0.3 weight %. Data on other supports and lower platinum loadings were not tested.

1.3 *This standard does not purport to address all of the safety concerns, if any, associated with its use. It is the responsibility of the user of this standard to establish appropriate safety and health practices and determine the applicability of regulatory limitations prior to use.*

2. Referenced Documents

2.1 *ASTM Standards:*²

[D3766 Terminology Relating to Catalysts and Catalysis](#)

[E177 Practice for Use of the Terms Precision and Bias in ASTM Test Methods](#)

[E456 Terminology Relating to Quality and Statistics](#)

[E691 Practice for Conducting an Interlaboratory Study to Determine the Precision of a Test Method](#)

3. Terminology

3.1 *Definitions*—See Terminology [D3766](#).

3.2 *Quality and Statistics*—See Terminology [E456](#).

3.3 *Precision and Bias*—See Practice [E177](#).

3.4 *Symbols*—The following symbols are used:

¹ This test method is under the jurisdiction of ASTM Committee D32 on Catalysts and is the direct responsibility of Subcommittee D32.01 on Physical-Chemical Properties.

Current edition approved April 1, 2008. Published May 2008. Originally approved in 1980. Last previous edition approved in 2003 as D3908-03. DOI: 10.1520/D3908-03R08.

² For referenced ASTM standards, visit the ASTM website, www.astm.org, or contact ASTM Customer Service at service@astm.org. For *Annual Book of ASTM Standards* volume information, refer to the standard's Document Summary page on the ASTM website.

| | | |
|----------------------|---|--|
| P_c | = | pressure of gas in calibrated bulb, torr |
| P_{mc} | = | pressure of gas in calibrated bulb and manifold, torr |
| P_m | = | pressure in manifold, torr |
| P_{md} | = | pressure in manifold and dead space, torr |
| P_{m_x} | = | pressure in manifold prior to expansion into sample tube for X equilibration point, torr |
| P_{e_x} | = | equilibrium pressure after expansion for generating X equilibrium point, torr |
| V_c | = | volume of calibrated bulb, cm ³ |
| V_m | = | volume of manifold between stopcocks 12 and 2 with only 4 and 1 open, cm ³ |
| V_d | = | volume of dead space in sample cell containing catalyst (volume between 2 and 3), cm ³ |
| $V_{ads}(STP)_x$ | = | volume of gas adsorbed at STP, cm ³ |
| $V_{ads}(STP)_{c_x}$ | = | cumulative volume of gas adsorbed through X, cm ³ |
| V_S | = | monolayer volume of gas adsorbed at STP, cm ³ |
| $T_{m_{Ax}}$ | = | temperature representative of the manifold prior to expansion into the sample cell, K |
| $T_{m_{Bx}}$ | = | temperature representative of the entire system after equilibrium pressure (P_{e_x}) has been established, K |
| T_m | = | temperature of manifold prior to expansion into sample cell for dead space determination, K |
| T_{m_D} | = | temperature of entire system after equilibrium pressure has been established for dead space determination, K |
| T | = | average manifold temperature for a given dose, K |
| | = | $(T_{m_{Ax}} + T_{m_{Bx}})/2$ |
| W_{cat} | = | mass of catalyst, g |
| X | = | weight percent of platinum |
| $\%D$ | = | percent platinum atoms on the surface |

4. Significance and Use

4.1 This test method sets forth a procedure by which duplicate catalyst samples can be compared either on an interlaboratory or intralaboratory basis. It is anticipated that catalyst producers and users will find this test method of value.

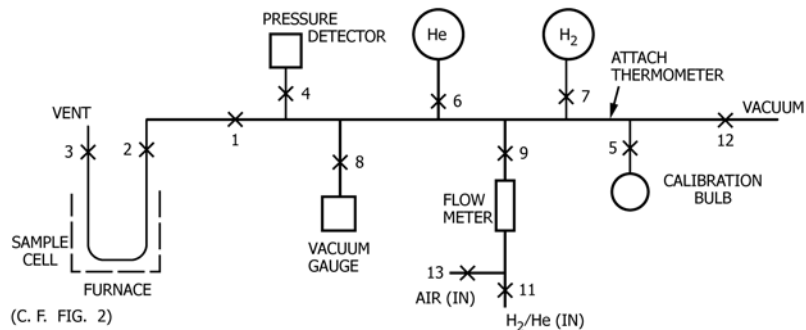

FIG. 1 Schematic: Static Vacuum System

4.2 Discrimination of the samples for which this procedure is recommended must be exercised when considering carrier (support) materials that sorb appreciable quantities of hydrogen or could cause an alteration of the state of the catalyst during pretreatment, or both, (that is, sintering or metal occlusion). These materials must be identified by the user and experimented with to determine the most significant conditions of measurement.

4.3 This test method provides a measure of the total hydrogen uptake (volume of hydrogen at STP, cm³/g of catalyst) without specifying the nature of the hydrogen-platinum interaction. Persons interested in using hydrogen uptake data to calculate percent platinum dispersion in a specific catalyst should be aware of carrier (support) interactions, spillover effects, and other phenomena related to the hydrogen uptake capabilities of the catalyst in question.

5. Apparatus

5.1 Gas-Handling System, as shown in Fig. 1. The components may be either glass or metal. Commercial metal instruments are available. The following components are to be included in the glass system:

5.1.1 Vacuum System, capable of attaining pressures below 1 mPa (1 × 10⁻⁵ torr). The vacuum can be monitored with any suitable vacuum gage. A diffusion pump backed by a mechanical pump must be isolated from the system by a trap held at liquid nitrogen temperature. High-vacuum stopcocks using a low-vapor pressure grease can be employed.

5.1.2 Pressure-Measuring Device, that operates at constant volume and that is capable of reading in the range from 0 to 66.7 kPa (0 to 500 torr) to the nearest 0.01 kPa (0.1 torr).

5.1.3 Calibration Bulb, whose volume has been carefully determined to within 0.1 % prior to attachment to the main manifold. Typically one fills the bulb and stopcock bore with mercury, weighs it, and calculates the volume of the bulb from the density of mercury at the temperature of the measurement. Following careful cleaning, the bulb is attached to the main manifold. One should make sure that the glass blowing is sufficiently far removed from the calibrated volume to avoid distortion.

5.1.4 Flow-Through Cell, that can be evacuated and that can be detached from the main manifold as, for example, see Fig. 2. This is accomplished by including a removable joint, if glass, a male cone joint, on the manifold end of the tube. (Other types of joints, that is, Swagelok with TFE-fluorocarbon

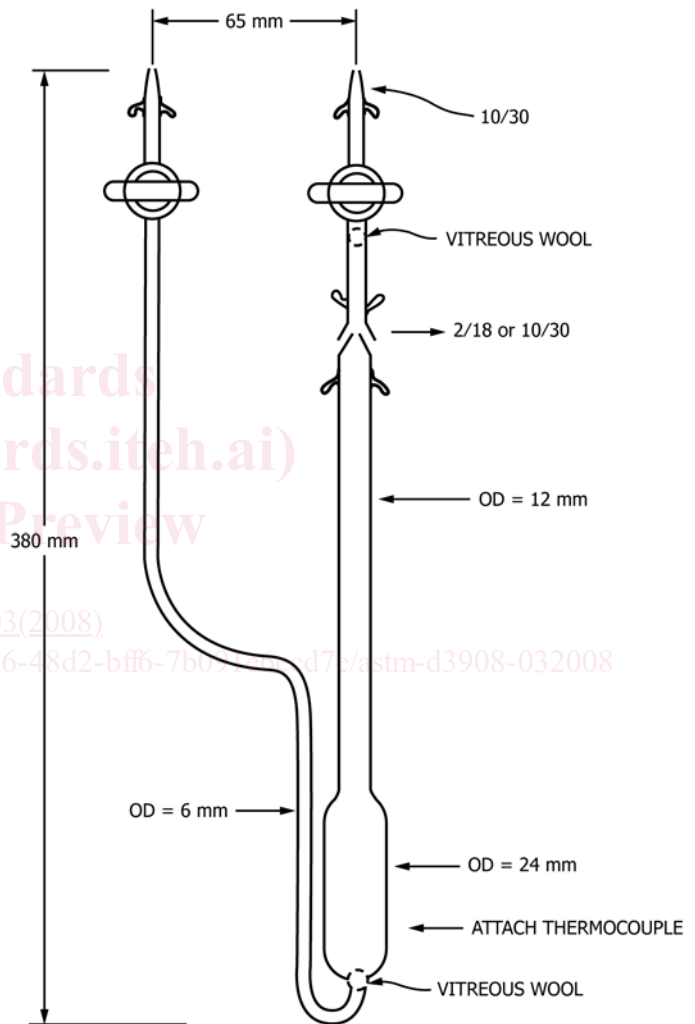

FIG. 2 Suitable Sample Cell

fittings, and so forth, are suitable.) Its mate is attached to the main manifold by a glass vacuum stopcock. A stopcock is also included on the vent side of the cell to allow for vacuum and flow-through procedures.

5.1.5 Catalyst Sample, secured by a quartz wool plug upstream of the catalyst and another quartz wool plug downstream (Fig. 2). The sample should be in the form of an extrudate, pellets, or powder greater than 20 mesh.