



Designation: F607 – 03(Reapproved 2008)

Standard Test Method for Adhesion of Gasket Materials to Metal Surfaces¹

This standard is issued under the fixed designation F607; the number immediately following the designation indicates the year of original adoption or, in the case of revision, the year of last revision. A number in parentheses indicates the year of last reapproval. A superscript epsilon (ϵ) indicates an editorial change since the last revision or reapproval.

This standard has been approved for use by agencies of the Department of Defense.

1. Scope

1.1 This test method provides a means of determining the degree to which gasket materials under compressive load adhere to metal surfaces. The test conditions described are indicative of those frequently encountered in gasket applications. Test conditions may also be modified in accordance with the needs of specific applications as agreed upon between the user and the producer. The maximum temperature recommended for this test method is 205°C (400°F).

1.2 The values stated in SI units are to be regarded as standard. The values in parentheses are for information only.

1.3 *This standard does not purport to address all of the safety concerns, if any, associated with its use. It is the responsibility of the user of this standard to establish appropriate safety and health practices and determine the applicability of regulatory limitations prior to use.*

2. Referenced Documents

2.1 *ASTM Standards:*²

F38 Test Methods for Creep Relaxation of a Gasket Material

F104 Classification System for Nonmetallic Gasket Materials

3. Summary of Test Method

3.1 The procedure described in this test method involves placing a specimen of a gasket material between flat platens of the desired metal, loading the assembly, and subjecting it to a specified set of conditions. The tensile force required to part the platen is measured in newtons or pounds-force and is recorded along with the calculated stress (force per unit area) in megapascals or pounds-force per square inch of gasket surface.

NOTE 1—This tensile force required to separate the platens may be in

¹ This test method is under the jurisdiction of ASTM Committee F03 on Gaskets and is the direct responsibility of Subcommittee F03.40 on Chemical Test Methods. Test apparatus prints are available at ASTM Headquarters.

Current edition approved April 1, 2008. Published May 2008. Originally approved in 1979. Last previous edition approved in 2003 as F607 – 03. DOI: 10.1520/F0607-03R08.

² For referenced ASTM standards, visit the ASTM website, www.astm.org, or contact ASTM Customer Service at service@astm.org. For *Annual Book of ASTM Standards* volume information, refer to the standard's Document Summary page on the ASTM website.

excess of 8896 N (2000 lbf).

NOTE 2—This fixturing also provides for the measurement of creep relaxation in accordance with Method B of Test Methods F38.

4. Significance and Use

4.1 This test method provides terms such as megapascals or pounds-force per square inch of gasket surface for expressing the extent of adhesion applicable to all materials within the scope of Classification System F104. Under certain conditions, adhesion develops when gasket materials are confined in a compressed state between metal flanges. Adhesion is important as an index of ease of removal of a gasket material. Since other variables may enter into the performance in an application, the results obtained should be correlated with field results. A typical set of conditions is described in this test method. This test method may be used as an acceptance test when agreed upon between the user and the producer.

5. Apparatus

5.1 *Circulating Air Oven*, capable of maintaining $100 \pm 2^\circ\text{C}$ ($212 \pm 3.6^\circ\text{F}$) or other specified temperature as agreed upon between the user and the producer.

5.2 *Test Fixture*,³ composed of two platens with holes 180° apart on the side of each platen, a calibrated bolt, washer, nut, (in accordance with the fixture in Test Method B of Test Methods F38) a dial indicator assembly, steel dowel pins, and a steel yoke or similar device to grip the dowel pins. The yoke, in turn, is attached to the grips of a test machine that will provide the capability of applying a tensile force perpendicular to the plane of the platen surface. See Fig. 1. Standard platen surface is smooth (as obtained using 8/0 dry garnet paper, refer to section 6.2), however, other surface finishes may be specified as agreed upon between the user and the producer.

5.3 *1/16 in. Box End Wrench*.

5.4 *Tension Tester*, capable of a rate of separation of grips of 1.3 mm (0.05 in.)/min equipped with a recording or a maximum indicating device.

5.5 *Tension Adapters*, that is, upper and lower yokes.

³ Composite test fixture including yokes available from Metal Samples Co. Inc., P.O. Box 8, Munford, AL 36268, have been found suitable.

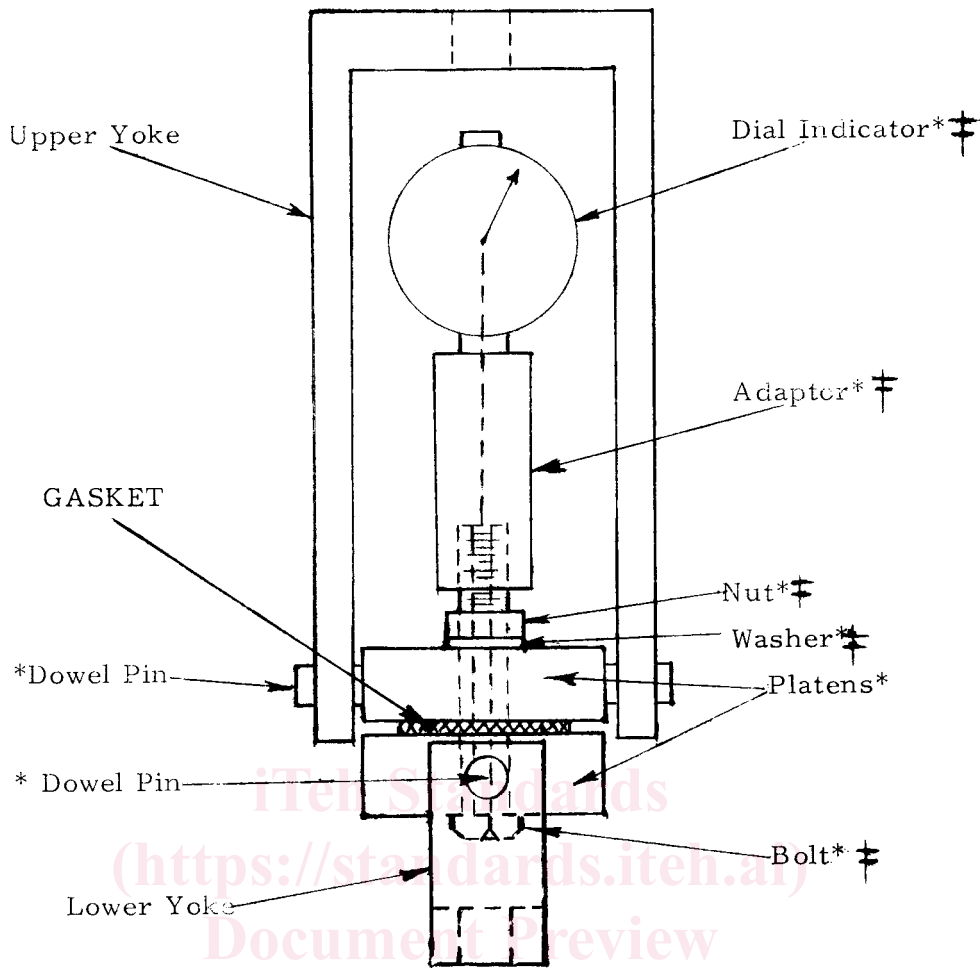

NOTE 1—The platens are flat, circular plates of the designated metal having a diameter of 76 mm (3 in.) and a minimum thickness of 25.4 mm (1 in.). A hole 10.3 mm (0.405 in.) in diameter shall be drilled through the center of each platen. The platens shall be chamfered slightly on all edges. Both sides shall be machined sufficiently to assure good parallelism of the surfaces. One side of each platen shall be finished to a profile of 60 μm . R_a (Roughness absolute) maximum (gasket side) utilizing a uniform finishing procedure as agreed upon by the participating laboratories.

FIG. 1 Composite Test Assembly for Adhesion of Gasket Materials to Metal Surfaces

5.6 % Dry Garnet Paper.

5.7 Molybdenum Disulfide, in powder or spray form.

6. Test Specimens

6.1 Three circular test specimens of material shall be tested. Care should be taken to cut cleanly, with minimum burrs or loose fibers. The surface of the material shall be kept clean, free of oil deposits or foreign material. No substances shall be used during the cutting operation for lubrication of the die or for any other purpose where they may come in contact with the specimen. Specimens shall be cut with an inside diameter of 32.25 to 32.31 mm (1.270 to 1.272 in.) and an outside diameter of 51.7 to 51.9 mm (2.035 to 2.045 in.).

6.2 The metal platens to be used in the test shall be prepared by removing all traces of previously tested gasket material. The 8/0 dry garnet paper, which has been fastened to a hard, smooth surface with the grit side facing up and held in a horizontal position, shall be used to provide the platen finish. The metal platen shall be firmly grasped or held by means of a suitable holder and the surface to be finished shall be rubbed against the

garnet paper. A reciprocating motion shall be used in a pattern of a figure eight and shall be continued until the platen has a uniform finish. If a serrated or non-standard platen surface is used then a soft bronze brush may be used for cleaning, and in such cases the surface finish should be measured using a suitable device prior to the next test. The platen shall then be washed clean with a laboratory grade of acetone to complete the removal of any foreign substance. Care should be taken after cleaning the platens to handle them by the edge prior to assembly for test. See 8.1 for time limitation after cleaning.

7. Conditioning

7.1 Condition the cut specimens in accordance with the procedure described for their classification in accordance with Classification System F104. The conditioning may be modified in accordance with the needs of specific applications as agreed upon between the user and the producer.

7.2 Hold the test fixture assembly—metal platens, calibrated bolt, washer, and nut at 21 to 27°C (70 to 80°F) for a period of at least 4 h immediately prior to assembly.